

 caple



Kitchen Appliance
COLLECTION | 2019

CONTENTS

COOKING

OVENS	12
STEAM OVENS	34
MICROWAVES	39
COFFEE MACHINES	48
WARMING AND STORAGE DRAWERS	52
HOBBS	58
EXTRACTION	90
VENTING	142
SPLASHBACKS	144

COOLING

PROFESSIONAL REFRIGERATION	154
FREESTANDING REFRIGERATION	156
INTEGRATED REFRIGERATION	163
WINE CABINETS	174

WASHING

DISHWASHERS	202
WASHING MACHINES	212
WASHER DRYER	214
TUMBLE DRYERS	216
PLINTH HEATERS	218
FOOD WASTE DISPOSAL	220
INSTALLATION DIAGRAMS	222
CAPLE CARE	248

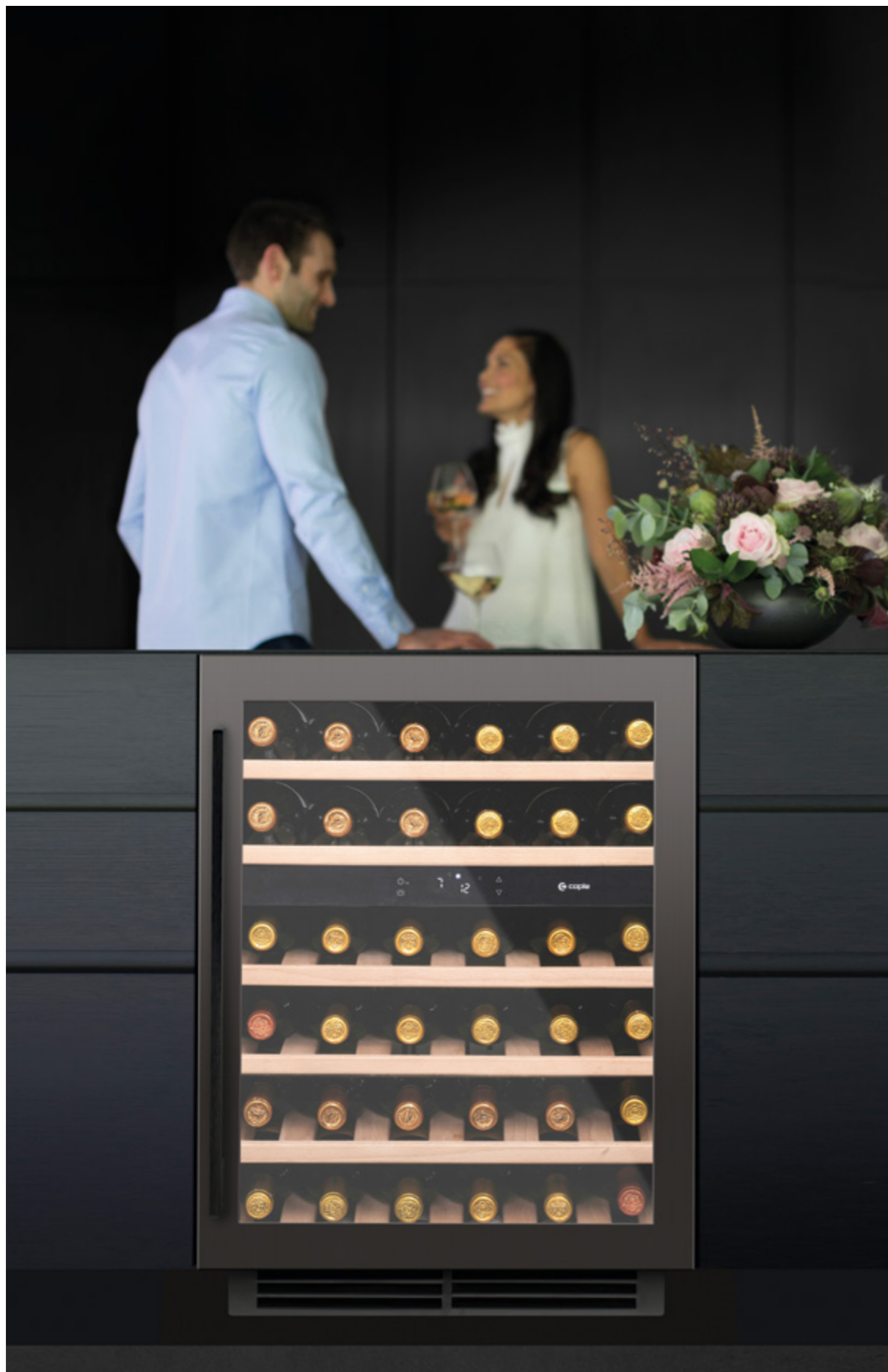

Making Functionality Fashionable

Beautiful, functional and technologically advanced, Caple appliances are central to the concept of a contemporary kitchen. From super sleek induction hobs to discretely effective cooker hoods, whisper quiet dishwashers and smart [in every sense] wine cabinets, they cater for every lifestyle.

Chef, entertainer, home maker? Whatever your passion Caple provides the inspiration to carry it off with exceptional style. Our range offers the depth and versatility to seamlessly integrate into your kitchen, whatever its design or layout. Discover exciting new ways to cook, cool or wash, but above all, bring out the beating heart of your home.



COOKING

OVENS	12
STEAM OVENS	34
MICROWAVES	38
COFFEE MACHINES	48
WARMING AND STORAGE DRAWERS	52
HOBBS	58
EXTRACTION	90
VENTING	142
SPLASHBACKS	144

COOKING THE WAY YOU WANT

Our oven range features the following functions, to make cooking as easy as pie.



DEFROST / TURBO DEFROST

- Fan only no elements
- No heat, fan only
- Uses fan power at room temperature to cut defrosting time in half

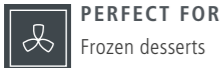

FULL GRILL

- Full width grill
- Even and consistent grilling



TURBO GRILL

- Fan assisted full grill
- Quick browning



TURBO GRILL PLUS FAN HEAT

- Fan assisted top element
- Heat from both rear and upper elements



ECO GRILL

- Half width grill
- Energy saving inner grill section only

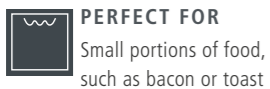

TURBO ECO GRILL

- Fan assisted half grill
- Even and quick browning

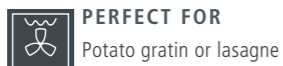

TOP HEAT

- Top element only
- Gentle heat to brown the top of a dish

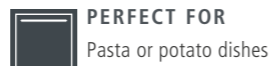

BASE HEAT

- Bottom element only
- Re-heating cooked food or for keeping food warm



TURBO BASE HEAT

- Fan assisted bottom element
- Designed for delicate and slow cooking

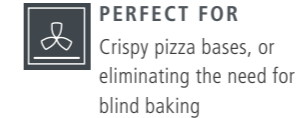

CONVENTIONAL HEAT

- Top and bottom elements
- Cooking consistently through to the middle
- Best results, use one shelf only



TURBO CONVENTIONAL HEAT

- Fan assisted top and bottom elements
- Fast and even heat distribution
- Ideal for cooking more than one food type without transferring smells or tastes



FAN HEAT

- Fan element
- Fast and highly efficient



ROTISSERIE

- Turns meat automatically as it cooks, so that it bastes itself

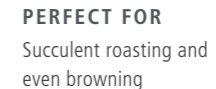



GAS COOKING

Uses the Euro burner
- Retains moisture in joints of meat

PERFECT FOR
Roast beef and crispy potatoes



GAS GRILL

Full width grill
- Even and quick browning

PERFECT FOR
Lamb cutlets or pork chops



STEAM

Steam Injection
- No transfer of flavours
- Retains moisture and locks in nutrients
- One of the healthiest cooking methods

PERFECT FOR
Cooking multiple food types on one tray



FAN HEAT WITH STEAM

Fan element and steam injection
- Fan element with added steam
- Even heat distribution with the added benefit of the steam injecting moisture into the cavity

PERFECT FOR
Retaining the moisture in meat



MotionHeat+

- Even heat distribution
- No flavour transfers across dishes

PERFECT FOR
Multi-level cooking



PYROLYTIC SELF-CLEANING

Works by heating the oven to 475°C, causing even hidden & baked-on grime to carbonise into a fine ash for easy cleaning.

PERFECT FOR
Taking the effort out of cleaning



BOOST

Rapidly heat your oven to the required temperature using all elements at full power. Ideal for when you're in a rush.

PERFECT FOR
When cooking time is less than 20 minutes



DESCALE

Take the hassle out of descaling your steam oven. Simply pour in the descaler to the water tank, select this function and let the machine do the rest. This is recommended every three months

PERFECT FOR
Prolonging the life of your steam oven.



MICROWAVE

Standard microwave cooking function.

PERFECT FOR
Ideal for reheating leftovers



MICROWAVE & TURBO GRILL

Uses microwave, fan and grill for quick browning. Ideal for cooking meat and keeping all the juices.

PERFECT FOR
Cooking a whole chicken



MICROWAVE & FAN HEAT

Reduce cooking times with the addition of fan heat for even cooking.

PERFECT FOR
Fluffy jacket potatoes with a crispy skin in a quarter of the time



MICROWAVE & CONVENTIONAL HEAT

Uses microwave with top and bottom elements.

PERFECT FOR
Speeding up baking times for bread and cakes



AUTO SETTINGS

A range of automatic settings for milk, soup, vegetables, noodles, bread, fish, meat & chicken

PERFECT FOR
Making soup from scratch



Ovens

There's a Caple oven for every kind of kitchen and every type of lifestyle. Choose from our sleek and elegant SENSE range or our exceptionally versatile Classic family.



SINGLE OVENS

With handy features like telescopic runners and soft close hinges, our built-in single ovens are big on looks and highly practical. The perfect solution when space is at a premium.

Look out for products marked with Sense or Classic flags to easily identify the range.

S C

SENSE OVENS

With a choice of sultry black glass and an elegant stainless steel trim or a subtle contemporary gunmetal exterior, SENSE appliances have been designed to fit together effortlessly and will turn heads in any kitchen. At the same time, smart thinking and intelligent solutions deliver the ultimate in easy functionality.

Featuring innovative touch control technology, every SENSE oven delivers outstanding results, whatever the cooking task.

MotionHeat+

MotionHeat+ technology utilises specially designed vents and fan heat to evenly distribute hot air around the oven cavity. It reaches the desired temperature rapidly with no need to preheat, saving time & energy. Perfect for multi-level cooking without the transfer of flavours, achieving even results every time.

TELESCOPIC RUNNERS

As standard, all SENSE ovens come with two full extension telescopic runners making it easier to check food as it cooks and reducing the risk of burning yourself on the oven interior.

ROTISSERIE

The C2901, C2105 and C2105GM single ovens feature a rotisserie rack, perfect for cooking succulent roasts.



SOFT CLOSE

The C2105 and C2105GM feature a intuitive soft-close hinge which activates when the door is inches away from the closed position preventing it from shutting abruptly.

PYROLYTIC OVENS P

The C2401 and C2401GM Pyrolytic technology works by heating the oven to 475°C, causing even hidden & baked-on grime to carbonise into a fine ash. It saves you vast amounts of elbow grease, and can in-fact improve oven efficiency over time.

PRECISION CONTROL AT YOUR FINGERTIPS

Our SENSE range features fully-programmable touch controls for precise and accurate cooking temperatures and times. Although, if you prefer the tactile feel of fixed dials, opt for the C2362 with solid metal controls.

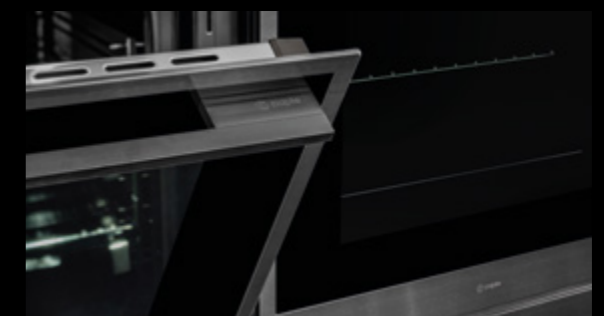

S Look out for products marked with Sense flags to easily identify the range.



SENSE ELECTRIC 90CM SINGLE OVEN

MotionHeat+



PRODUCT CODE

S C2901

DIMENSIONS

↔ w:900mm

PERFORMANCE

e Energy class A

FINISH AVAILABLE

■ Black glass with stainless steel trim

FUNCTIONS

13 Functions

- Light
- Base heat
- Conventional heat
- Fan heat
- Turbo grill plus fan heat
- Turbo conventional heat
- Full grill
- Eco grill
- Turbo eco grill
- Turbo grill
- Turbo base heat
- Defrost
- Boost [rapid preheat]

OVEN FEATURES

- MotionHeat+ technology
- 95 Litre XL capacity
- Full touch control
- Programmable electronic timer
- Self-cleaning catalytic liners [back and sides]
- Easy clean enamel interior
- Two internal lights
- Closed door grilling
- Rotisserie cooking
- Easy to remove chrome shelf racks
- Triple glazed door
- Full width inner door glass
- Tangential cooling fan

DESIGN

- Square bar handle
- White LED display

ACCESSORIES

- 2 Safety-stop shelves
- 1 Grill pan with handle
- 2 sets of full extension telescopic runners
- 1 Rotisserie rack

INSTALLATION

- Diagram [p.222]
- Rated load 3.65kW
- Fuse rating 16A



SENSE ELECTRIC PYROLYTIC SINGLE OVENS

MotionHeat+



C2401

MotionHeat+



C2401GM

PRODUCT CODE

S Black glass C2401
S Gunmetal C2401GM

DIMENSIONS

↔ w:600mm

PERFORMANCE

e Energy class A

FINISH AVAILABLE

■ Black glass with stainless steel trim
■ Gunmetal and black glass

FUNCTIONS

13 Functions

- Light
- Base heat
- Conventional heat
- Fan heat
- Turbo grill plus fan heat
- Turbo conventional heat
- Full grill
- Eco grill
- Turbo grill
- Turbo base heat
- Pyrolytic self cleaning
- Defrost
- Boost [rapid preheat]

OVEN FEATURES

- MotionHeat+ technology
- 67 Litre capacity
- Full touch control
- Programmable electronic timer
- Pyrolytic self-cleaning
- Easy clean enamel interior
- Two internal lights
- Closed door grilling
- Easy to remove chrome shelf racks
- Quadruple glazed door
- Full width inner door glass
- Tangential cooling fan

DESIGN

- Stainless steel square bar handle [C2401]
- Black square bar handle [C2401GM]
- White LED display

ACCESSORIES

- 2 Safety-stop shelves
- 1 Grill pan with handle
- 2 Sets of full extension telescopic runners

OPTIONAL EXTRAS

- 1 Wire shelf [SHELF4]
- 1 Baking tray [TRAY4]
- Pair of full extension telescopic runners [CAPRACK8]
- 1 Steam set [STEAMSET]
Visit caple.co.uk for full range

INSTALLATION

- Diagram [p.222]
- Rated load 3.57kW
- Fuse rating 20A

Features

PYROLYTIC CLEANING

The Pyrolytic technology works by heating the oven to 475°C, causing even hidden & baked-on grime to carbonise into a fine ash. It saves you vast amounts of elbow grease, & actually improves oven efficiency over time too.

FUNCTIONS

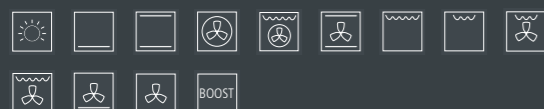

FUNCTIONS





SENSE ELECTRIC SOFT CLOSE SINGLE OVENS



C2105



C2105GM

PRODUCT CODE

- S** Black Glass C2105
- S** Gunmetal C2105GM

DIMENSIONS

↔ w:600mm

PERFORMANCE

e Energy class A

FINISH AVAILABLE

- Black glass with stainless steel trim
- Gunmetal and black glass

FUNCTIONS

13 Functions

- Light
- Base heat
- Conventional heat
- Fan heat
- Turbo grill plus fan heat
- Turbo conventional heat
- Full grill
- Eco grill
- Turbo Eco grill
- Turbo grill
- Turbo base heat
- Defrost
- Boost [rapid preheat]

OVEN FEATURES

- MotionHeat+ technology
- 67 Litre capacity
- Full touch control
- Programmable electronic timer
- Soft-close door
- Self-cleaning catalytic liners [back and sides]
- Easy clean enamel interior
- Two internal lights
- Closed door grilling
- Rotisserie cooking
- Easy to remove chrome shelf racks
- Triple glazed door
- Full width inner door glass
- Tangential cooling fan

DESIGN

- Stainless steel square bar handle [C2105]
- Black square bar handle [C2105GM]
- White LED display

ACCESSORIES

- 2 Safety-stop shelves
- 1 Grill pan with handle
- 2 sets of full extension telescopic runners

OPTIONAL EXTRAS

- 1 Wire shelf [SHELF4]
 - 1 Baking tray [TRAY3]
 - Pair of full extension telescopic runners [CAPRACK8]
 - 1 Steam set [STEAMSET]
- Visit caple.co.uk for full range

INSTALLATION

- Diagram [p.222]
- Rated load 3.22kW
- Fuse rating 16A

Features

SOFT CLOSE

The intuitive soft close hinge prevents the door from shutting abruptly bringing it gently into position.

SENSE ELECTRIC SINGLE OVEN



PRODUCT CODE

S C2101

DIMENSIONS

↔ w:600mm

PERFORMANCE

e Energy class A

FINISH AVAILABLE

- Black glass with stainless steel trim

FUNCTIONS

10 Functions

- Light
- Base heat
- Conventional heat
- Fan heat
- Turbo conventional heat
- Full grill
- Eco grill
- Turbo grill
- Defrost
- Boost [rapid preheat]

OVEN FEATURES

- MotionHeat+ technology
- 67 Litre capacity
- Full touch control
- Programmable electronic timer
- Self-cleaning catalytic liners [back and sides]
- Easy clean enamel interior
- Two internal lights
- Closed door grilling
- Easy to remove chrome shelf racks
- Double glazed door
- Full width inner door glass
- Tangential cooling fan

DESIGN

- Square bar handle
- White LED display

ACCESSORIES

- 2 Safety-stop shelves
- 1 Grill pan with handle
- 2 sets of full extension telescopic runners

OPTIONAL EXTRAS

- 1 Wire shelf [SHELF4]
 - 1 Baking tray [TRAY3]
 - Pair of full extension telescopic runners [CAPRACK8]
 - 1 Steam set [STEAMSET]
- Visit caple.co.uk for full range

INSTALLATION

- Diagram [p.222]
- Rated load 3.22kW
- Fuse rating 16A

FUNCTIONS

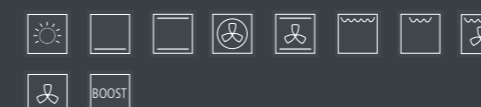

SENSE ELECTRIC SINGLE OVEN



PRODUCT CODE

S C2362

DIMENSIONS

↔ w:600mm

PERFORMANCE

e Energy class A

FINISH AVAILABLE

- Black glass with stainless steel trim

FUNCTIONS

8 Functions

- Light
- Conventional heat
- Fan heat
- Full grill
- Eco grill
- Turbo grill
- Turbo base heat
- Defrost

OVEN FEATURES

- MotionHeat+ technology
- 67 Litre capacity
- Touch control programmable electronic timer
- Metal dial controls
- Self-cleaning catalytic liners [back and sides]
- Easy to clean enamel interior
- Two internal lights
- Closed door grilling
- Easy to remove chrome shelf racks
- Double glazed door
- Full width inner door glass
- Tangential cooling fan

DESIGN

- Square bar handle
- White LED display

ACCESSORIES

- 2 Safety-stop shelves
- 1 Grill pan with handle
- 2 sets of full extension telescopic runners

OPTIONAL EXTRAS

- 1 Wire shelf [SHELF4]
 - 1 Baking tray [TRAY3]
 - Pair of full extension telescopic runners [CAPRACK8]
 - 1 Steam set [STEAMSET]
- Visit caple.co.uk for full range

INSTALLATION

- Diagram [p.222]
- Rated load 3.22kW
- Fuse rating 16A

FUNCTIONS



FUNCTIONS

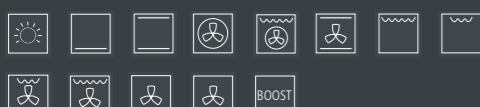



CLASSIC OVENS

Our high-performance Classic range comes with a host of standard and optional features, designed to make cooking even more satisfying.

These ovens are classically designed, as the name suggests, in stainless steel and sheer black glass. You'll find fully programmable electronic timers, cool-touch doors that are as good as their name suggests plus pyrolytic self-cleaning models.



COOL-TOUCH DOORS

Double, triple and quadruple glazed doors that remain cool during cooking with heat-reflective glass and a tangential cooling fan.



MotionHeat+ technology utilises specially designed vents and fan heat to evenly distribute hot air around the oven cavity. It reaches the desired temperature rapidly with no need to preheat, saving time & energy. Perfect for multi-level cooking without the transfer of flavours achieving even results every time.

TOUCH CONTROL PROGRAMMABLE ELECTRONIC TIMERS & SOLID METAL DIALS

You can preset cooking start and stop times with ease of use and precise control at your fingertips.

LARGE VIEWING WINDOW WITH A LARGE CAPACITY TO MATCH

For more efficient cooking you can keep an eye on exactly what you're cooking without having to open the door and lose heat. Some single ovens also have a capacity as large as 67 litres, perfect for a hungriest of households.

C Look out for products marked with Classic flags to easily identify the range.



COOKING

20

21

SINGLE OVENS



CLASSIC ELECTRIC PYROLYTIC SINGLE OVEN

MotionHeat+



Features

PYROLYTIC CLEANING

The Pyrolytic technology works by heating the oven to 475°C, causing even hidden & baked-on grime to carbonise into a fine ash. It saves you vast amounts of elbow grease, & actually improves oven efficiency over time too.

ELECTRONIC THERMOSTAT

For precise temperature control.

TELESCOPIC RUNNERS

The C2239 oven comes with two full extension telescopic runners making it easier to check food as it cooks and reducing the risk of burning yourself on the oven interior.

PRODUCT CODE

C C2239

DIMENSIONS

↔ w:600mm

PERFORMANCE

e Energy class A

FINISH AVAILABLE

■ Stainless steel with black glass

FUNCTIONS

11 Functions

- Light
- Defrost
- Conventional heat
- Fan heat
- Eco grill
- Full grill
- Turbo grill
- Turbo base heat
- Turbo conventional heat
- Boost [rapid preheat]
- Pyrolytic self-cleaning

OVEN FEATURES

- MotionHeat+ technology
- 67 Litre capacity
- Touch control programmable electronic timer

- Electronic dial controls
- Easy to clean enamel interior
- Quadruple glazed door
- Door safety lock during pyrolytic function
- Internal light
- Closed door grilling
- Easy to remove chrome shelf racks
- Full width inner door glass
- Tangential cooling fan

DESIGN

- Square bar handle
- Green LED display

ACCESSORIES

- 1 Safety-stop shelf
- 1 Grill pan and rack with handle
- 2 sets of full extension telescopic runners [CAPRACK8]

OPTIONAL EXTRAS

- 1 Wire shelf [SHELF4]
 - Pair of full extension telescopic runners [CAPRACK8]
 - Steam set [STEAMSET]
 - 1 Baking tray [TRAY4]
- Visit cagle.co.uk for full range

INSTALLATION

- Diagram [p.223]
- Rated load 3.57kW
- Fuse rating 20A



CLASSIC ELECTRIC SINGLE OVEN

MotionHeat+



PRODUCT CODE

C C2237

DIMENSIONS

↔ w:600mm

PERFORMANCE

e Energy class A

FINISH AVAILABLE

■ Stainless steel with black glass

FUNCTIONS

9 Functions

- Light
- Defrost
- Conventional heat
- Fan heat
- Eco grill
- Full grill
- Turbo grill
- Turbo base heat
- Turbo conventional heat

OVEN FEATURES

- MotionHeat+ technology
- 67 Litre capacity
- Touch control programmable electronic timer

- Metal dial controls
- Easy to clean enamel interior
- Double glazed door
- Internal light
- Closed door grilling
- Easy to remove chrome shelf racks
- Full width inner door glass
- Tangential cooling fan

DESIGN

- Square bar handle
- Green LED display

ACCESSORIES

- 1 Safety-stop shelf
- 1 Grill pan and rack with handle

OPTIONAL EXTRAS

- 1 Wire shelf [SHELF4]
 - Pair of full extension telescopic runners [CAPRACK8]
 - Steam set [STEAMSET]
 - 1 Baking tray [TRAY3]
- Visit cagle.co.uk for full range

INSTALLATION

- Diagram [p.223]
- Rated load 3.2kW
- Fuse rating 16A

FUNCTIONS



FUNCTIONS



CLASSIC ELECTRIC SINGLE OVENS

MotionHeat+



C2234

MotionHeat+



C2234BK

PRODUCT CODE

- C** Stainless Steel C2234
- C** Black Glass C2234BK

DIMENSIONS

- w:600mm

PERFORMANCE

- e** Energy class A

FINISH AVAILABLE

- Stainless steel with black glass
- Black glass

FUNCTIONS

- 5** Functions

- Light
- Defrost
- Fan heat
- Full grill
- Turbo grill

OVEN FEATURES

- MotionHeat+ technology
- 67 Litre capacity
- Touch control programmable electronic timer
- Metal dial controls
- Easy to clean enamel interior
- Double glazed door
- Internal light
- Closed door grilling
- Easy to remove chrome shelf racks
- Full width inner door glass
- Tangential cooling fan

DESIGN

- Square bar handle
- Green LED display

ACCESSORIES

- 1 Safety-stop shelf
- 1 Grill pan and rack with handle

OPTIONAL EXTRAS

- 1 Wire shelf [SHELF4]
- Pair of full extension telescopic runners [CAPRACK8]
- Steam set [STEAMSET]
- 1 Baking tray [TRAY3]
Visit caple.co.uk for full range

INSTALLATION

- Diagram [p.223]
- Rated load 2.34kW
- Fuse rating 13A

Features



LARGE VIEWING WINDOW WITH A LARGE CAPACITY TO MATCH

For more efficient cooking you can keep an eye on exactly what's in the oven without opening the door and losing heat.



FUNCTIONS





CLASSIC ELECTRIC SINGLE OVEN

MotionHeat+



PRODUCT CODE

C C2231

DIMENSIONS

↔ w:600mm

PERFORMANCE

e Energy class A

FINISH AVAILABLE

■ Stainless steel with black glass

FUNCTIONS

5 Functions

- Light
- Defrost
- Fan heat
- Full grill
- Turbo grill

OVEN FEATURES

- MotionHeat+ technology
- 67 Litre capacity
- Audible minute minder
- Metal dial controls
- Easy to clean enamel interior
- Double glazed door
- Internal light
- Closed door grilling
- Easy to remove chrome shelf racks
- Full width inner door glass
- Tangential cooling fan

DESIGN

- Square bar handle

ACCESSORIES

- 1 Safety-stop shelf
- 1 Grill pan and rack with handle

OPTIONAL EXTRAS

- 1 Wire shelf [SHELF4]
 - Pair of full extension telescopic runners [CAPRACK8]
 - Steam set [STEAMSET]
 - 1 Baking tray [TRAY3]
- Visit caple.co.uk for full range

INSTALLATION

- Diagram [p.223]
- Rated load 2.34kW
- Fuse rating 13A

FUNCTIONS



CLASSIC SIDE OPENING ELECTRIC SINGLE OVEN

MotionHeat+



PRODUCT CODE

C C2220

DIMENSIONS

↔ w:600mm

PERFORMANCE

e Energy class A

FINISH AVAILABLE

■ Stainless steel with black glass

FUNCTIONS

5 Functions

- Light
- Defrost
- Fan heat
- Full grill
- Turbo grill

OVEN FEATURES

- MotionHeat+ technology
- 67 Litre capacity
- Touch control programmable electronic timer
- Reversible door
- Metal dial controls
- Easy to clean enamel interior
- Double glazed door
- Internal light
- Closed door grilling
- Easy to remove chrome shelf racks
- Full width inner door glass
- Tangential cooling fan

DESIGN

- Square bar handle
- Green LED display

ACCESSORIES

- 1 Safety-stop shelf
- 1 Grill pan and rack with handle

OPTIONAL EXTRAS

- 1 Wire shelf [SHELF4]
 - Pair of full extension telescopic runners [CAPRACK8]
 - Steam set [STEAMSET]
 - 1 Baking tray [TRAY3]
- Visit caple.co.uk for full range

INSTALLATION

- Diagram [p.223]
- Rated load 2.34kW
- Fuse rating 13A

Features

SIDE OPENING DOORS

The side opening door allows for easy access inside the oven cavity without having to manoeuvre around the door. This means you can get closer to the oven which is handy when cleaning

SIDE-BY-SIDE

Create a side-by-side double oven look utilising the reversible door feature.

FUNCTIONS



DOUBLE OVENS



When mass catering is on the cards, Caple comes up trumps. Our Sense and Classic ranges offer the capacity and the functions you need to satisfy the largest appetites.

Look out for products marked with Sense and Classic flags to easily identify the ranges.



SENSE ELECTRIC DOUBLE OVEN



PRODUCT CODE

S C3371

DIMENSIONS

↔ w:595mm

PERFORMANCE

e Top Oven A
Bottom Oven A

FINISH AVAILABLE

■ Black glass with stainless steel trim

FUNCTIONS

4 Top Oven

- Conventional Heat
- Full Grill
- Base Heat
- Top Heat

8 Bottom Oven

- Light
- Turbo defrost
- Conventional heat
- Fan heat
- Eco grill
- Full grill
- Turbo grill
- Turbo base heat

OVEN FEATURES

Top Oven

- 40 Litre capacity [top oven]

Bottom Oven

- 61 Litre capacity [bottom oven]

GENERAL

- MotionHeat+ technology
- Touch control programmable electronic timer
- Metal dial controls
- Triple glazed doors with heat reflective glass
- Easy clean enamel interior
- Removable chrome shelf racks
- Catalytic liners in both oven cavities
- Tangential cooling fan

DESIGN

- Square bar handle
- White LED display

ACCESSORIES

- 1 Safety stop shelf in top oven
- 1 Safety stop shelf in bottom oven
- 1 Grill pan with handle in top oven
- 1 Enamelled baking tray in bottom oven
- 2 Pairs of full extension telescopic runners

OPTIONAL EXTRAS

- 1 Wire shelf [SHELF3]
- 1 set of full extension telescopic runners [CAPRACK8]
- Steamset [STEAMSET]
Visit caple.co.uk for full range

INSTALLATION

- Diagram [p.223]
- Rated load 5.19kW
- Fuse rating 32A

Please note this product has not been designed to suit a quad or linear installation. See pages 56-57 for recommended combinations.

FUNCTIONS



CLASSIC ELECTRIC DOUBLE OVEN



PRODUCT CODE

C C3248

DIMENSIONS

w:595mm

PERFORMANCE

e Top Oven A
Bottom Oven A

FINISH AVAILABLE

Stainless steel with black glass

FUNCTIONS

4 Top Oven

- Conventional heat
- Full grill
- Base heat
- Top heat

8 Bottom Oven

- Light
- Turbo defrost
- Fan heat
- Turbo grill
- Conventional heat
- Turbo base heat
- Eco grill
- Full grill

OVEN FEATURES

Top Oven

- 40 Litre capacity [top oven]

Bottom Oven

- 61 Litre capacity [bottom oven]

GENERAL

- Triple glazed doors with heat reflective glass
- Easy clean enamel interior
- Removable chrome shelf racks
- Tangential cooling fan
- Touch control programmable electronic timer

DESIGN

- Stainless steel, black-spot feature bar handles
- Green LED display

ACCESSORIES

- 1 Safety-stop shelf in top oven
- 1 Safety-stop shelf in bottom oven
- 1 Grill pan with handle in top oven
- 1 Enamelled baking tray in bottom oven

OPTIONAL EXTRAS

- Spare shelf [SHELF3]
- Oven steam set [STEAMSET]
- Pair of telescopic runners [CAPRACK7]

Visit caple.co.uk for full range

INSTALLATION

- Diagram [p.223]
- Rated load 5.19kW
- Fuse rating 32A



CLASSIC ELECTRIC DOUBLE OVEN



PRODUCT CODE

C C3246

DIMENSIONS

w:595mm

PERFORMANCE

e Top Oven A
Bottom Oven A

FINISH AVAILABLE

Stainless steel and black glass

FUNCTIONS

4 Top Oven

- Conventional heat
- Full grill
- Base heat
- Top heat

4 Bottom Oven

- Light
- Turbo defrost
- Fan heat
- Turbo grill

GENERAL

- Triple glazed doors with heat reflective glass
- Easy clean enamel interior
- Removable chrome shelf racks
- Tangential cooling fan
- Programmable electronic timer

DESIGN

- Square bar handle
- Green LED display

ACCESSORIES

- 1 Safety-stop shelf in top oven
- 1 Safety-stop shelf in bottom oven
- 1 Grill pan with handle in top oven
- 1 Enamelled baking tray in bottom oven

OPTIONAL EXTRAS

- Spare shelf [SHELF3]
 - Oven steam set [STEAMSET]
 - Pair of telescopic runners [CAPRACK7]
- Visit caple.co.uk for full range

INSTALLATION

- Diagram [p.223]
- Rated load 5.19kW
- Fuse rating 32A

OVEN FEATURES

Top Oven

- 40 Litre capacity [top oven]

Bottom Oven

- 61 Litre capacity [bottom oven]

Features

OVEN DOORS

The triple glazed doors with heat reflective glass and full width sealed inner door glass makes these oven doors perfect for those looking to entertain regularly.



LED TOUCH CONTROL

The C3248 intuitive control lets you swiftly access all functions, the electronic cooking timer, end time, minute minder and clock.



STEAMSET

Time to ditch the frying pan and try a healthier cooking experience. [Compatible for use with C3371, C3246, C3248, C4246, C2101, C2105, C2105GM, C2362, C2401, C2401GM, C2239, C2237, C2234, C2234BK, C2231 and C2220]



See page 33 for more details.

FUNCTIONS



FUNCTIONS





BUILT-UNDER OVEN

Neat, versatile and with a host of clever design features, our built-under ovens fit perfectly beneath the worktop. Grill in the top oven whilst fan cooking in the bottom - the ultimate tool in multi-tasking cooking.

CLASSIC ELECTRIC BUILT-UNDER OVEN



PRODUCT CODE
C C4246

DIMENSIONS
w:595mm

PERFORMANCE
e Top Oven A
Bottom Oven A+

FINISH AVAILABLE
Stainless steel and black glass

FUNCTIONS
4 Top Oven

- Conventional heat
- Full grill
- Base heat
- Top heat

8 Bottom Oven

- Light
- Turbo defrost
- Fan heat
- Conventional heat
- Turbo base heat
- Base heat
- Top heat
- Turbo conventional heat

OVEN FEATURES

- Top Oven**
- 40 Litre capacity
- Bottom Oven**
- 42 Litre capacity

- GENERAL**
- Triple glazed doors with heat reflective glass
 - Easy clean enamel interior
 - Removable chrome shelf racks
 - Tangential cooling fan
 - Touch control programmable electronic timer

- DESIGN**
- Square bar handle
 - Green LED display

- ACCESSORIES**
- 1 Safety-stop shelf in top oven
 - 1 Safety-stop shelf in bottom oven
 - 1 Grill pan with handle
 - 1 Enamelled baking tray

- OPTIONAL EXTRAS**
- Spare shelf [SHELF3]
 - Oven steam set [STEAMSET]
 - Pair of telescopic runners [CAPRACK7]
- Visit caple.co.uk for full range

- INSTALLATION**
- Diagram [p.224]
 - Rated load 4.7kW
 - Fuse rating 20A

Accessories



STEAMSET

PRODUCT CODE
STEAMSET

- SUITABLE WITH**
- C3246
 - C3248
 - C4246
 - C2101
 - C2105
 - C2105GM
 - C2362
 - C2401
 - C2401GM
 - C2239
 - C2237
 - C2234 / BK
 - C2231
 - C2220

- INCLUDES**
- 1 Enamel tray with glass lid
 - 1 large perforated steam tray
 - 1 gastro tub
 - 1 perforated gastro tub
 - 1 chrome stand for gastro tubs

Steamset must be placed on wire racks not the telescopic runners for the following

- C3371

FUNCTIONS





Steam Ovens

Better taste and better for you.

Steam cooking is healthy, fuss-free and ensures fresh food retains its natural colours, flavours and shape. What's more, all the natural nutrients and goodness end up on the plate and not in the pan.

Oh, and it is also one of the most energy-efficient ways to cook food.

COMBINATION STEAM COOKING

Steam cooking is especially well suited to cooking foods like seafood, bread, vegetables, pasta and rice - the sky's the limit.

Utilising the combined functions of a steam oven - fan, steam, and grill - you can be sure to beautifully capture flavour at every turn. From delicate fish and perfectly baked bread to cooking succulent joints of meat with fan and steam to lock in moisture, combination cooking has never been so easy.



TOUCH CONTROLS AND LCD DISPLAY

The intuitive full touch control panel lets you swiftly access all functions, as well as the programmable electronic timer and electronic clock. You can also view the current cooking time and the actual temperature in the cavity.

DELICIOUS DESSERTS

Combining fan heat [dry heat] with steam [moisture] is the optimum environment for making perfect light pastry or cakes.

ODOURLESS COOKING

There are no food odours with steam. This means you can prepare different parts of a meal together, without the flavours mingling. You can save energy too by cooking your meat and vegetables together.

LARGE VIEWING WINDOW

From the display panel select the light function to check what is cooking without steam escaping the cavity.



SENSE BUILT-IN COMBINATION STEAM OVENS



SO110



SO110GM

Features

EASY CLEAN STAINLESS STEEL INTERIOR

The beautiful stainless steel interior means the cavity can simply be wiped clean after every use.

PRODUCT CODE

S	Black Glass	SO110
S	Gunmetal	SO110GM

DIMENSIONS

h:450mm

PERFORMANCE

Energy class A

FINISH AVAILABLE

- Black glass with stainless steel trim
- Gunmetal and black glass

FUNCTIONS

10 Functions

- Light
- Defrost
- Fan heat
- Full grill
- Turbo grill
- Steam
- Turbo grill and steam
- Fan heat with steam
- Descale
- Boost [rapid preheat]

OVEN FEATURES

- 36 Litre capacity
- Full touch control
- Programmable electronic timer
- Electronic clock
- Stainless steel interior
- Chrome shelf racks with 4 positions
- Internal light
- Double glazed removeable door
- Descaling programme
- Steam cooking 40 - 100°C

DESIGN

- Square bar handle
- Stainless steel interior
- White display

ACCESSORIES

- 1 Shelf
- 1 Grill pan and handle
- 1 Steam tray

OPTIONAL EXTRAS

- Gastro tubs [GTUB]
 - 1 Descaler liquid [DESCALER]
- Visit caple.co.uk for full range

INSTALLATION

- Diagram [p.224]
- Rated load 3.05kW
- Fuse rating 16A
- Fan cooking 1680W
- Steam cooking 1740W
- Grill 1450W

FUNCTIONS





Microwaves

Caple microwaves are packed with clever technology, and perfect for making quick and easy snacks as well as serious cooking. A must-have for a busy lifestyle.

DELICIOUS MEALS IN MINUTES



Minimalist design to complement any kitchen, yet big on handy features.

Depending on your cooking requirements, you can choose a microwave for its traditional uses such as warming up leftovers or defrosting food quickly. Alternatively, why not opt for a combination microwave? As well as cooking meals quickly, you can also use it as a normal oven and grill providing extra space when you are entertaining.

TURNTABLE FREE DESIGN

Caple microwaves have been exquisitely designed to look the part. Some models have 40L capacity, removable dishwasher friendly glass base and a turntable free design. This means you can fit large dishes into the cavity.



SENSE MICROWAVES

If you are in need of a traditional microwave to heat up your leftovers, the CM108 is the perfect choice. Or, if you're feeling more adventurous in the kitchen, try the CM110 combination microwave with a range of cooking options to enjoy. The CM110 is available in Black or Gunmetal.



CLASSIC MICROWAVES

Want to create a seamless built in look? The Classic range allows you to neatly arrange the bank of appliances in a linear or stacked formation so you can match your oven and microwave perfectly.



SENSE BUILT-IN COMBINATION MICROWAVES



CM110



CM110GM

Features

GREAT RESULTS

Achieve great results by combining the fan or grill together, or just regular convection cooking. Everything you need, in a microwave.

CONVECTION COOKING

Bringing together a ring element and a fan to provide evenly cooked and browned results. It's quicker than conventional cooking and can be combined with the microwave to reduce cooking time even more, the grill for perfect browning or both the microwave and grill together.

TURBO GRILL

The fan cooking system and grill deliver perfect results in all kinds of meals. It even locks in meat juices for better flavour.

PRODUCT CODE

S	Black Glass	CM110
S	Gunmetal	CM110GM

DIMENSIONS

h:450mm

FINISH AVAILABLE

	Black glass with stainless steel trim
	Gunmetal and black glass

FUNCTIONS

10 Functions

- Light
- Microwave [10 power levels]
- Auto Defrost
- Turbo Grill
- Fan heat
- Turbo conventional
- Microwave and fan heat
- Microwave and turbo grill
- Microwave and conventional heat
- Auto cooking

FEATURES

- 40 Litre capacity
- Full touch control
- Programmable electronic timer
- Electronic clock
- Turntable free design
- Chrome shelf rack with 3 positions
- Internal light
- Double glazed removable door
- Child safety lock
- 8 Auto cooking programmes
- Auto-defrost

AUTO COOKING PROGRAMMES

- Milk
- Soup
- Vegetables
- Noodles
- Bread
- Fish
- Meat
- Chicken

DESIGN

- Stainless steel square bar handle [CM110]
- Black square bar handle [CM110GM]
- Stainless steel interior
- White LED display

ACCESSORIES

- 1 Shelf
- 1 Baking tray
- 1 Glass base plate

INSTALLATION

- Diagram [p.224]
- Rated load 2.55kW
- Fuse rating 13A

COOKING OUTPUT

- Microwave cooking 1000W
- Grill 1000W



SENSE BUILT-IN MICROWAVE



PRODUCT CODE

S CM108

DIMENSIONS

h:450mm

FINISH AVAILABLE

Black glass with stainless steel trim

FUNCTIONS

4 Functions

- Light
- Microwave [10 power levels]
- Auto defrost
- Auto cooking

FEATURES

- 40 Litre capacity
- Full Touch control
- Programmable electronic timer
- Electronic clock
- Turntable free design
- Internal light
- Double glazed removable door
- 10 power levels
- Child safety lock
- Auto-defrost
- 8 Auto cooking programmes

AUTO COOKING PROGRAMMES

- Milk
- Soup
- Vegetables
- Noodles
- Bread
- Fish
- Meat
- Chicken

DESIGN

- Square bar handle
- Stainless steel interior
- White LED display

ACCESSORIES

- 1 Glass base plate

INSTALLATION

- Diagram [p.224]
- Rated load 1.5kW
- Fuse rating 10A

COOKING OUTPUT

- Microwave cooking 1000W

FUNCTIONS



FUNCTIONS



CLASSIC BUILT-IN MICROWAVES



CM108SS



CM108BK

PRODUCT CODE

C Stainless Steel CM108SS

C Black Glass CM108BK

DIMENSIONS

 h:450mm

FINISH AVAILABLE

 Stainless steel and black glass

 Black glass

FUNCTIONS

4 Functions

- Light
- Microwave [10 power levels]
- Auto Defrost
- Auto cooking

FEATURES

- 40 Litre capacity
- Full touch control
- Programmable electronic timer
- Electronic clock
- Turntable free design
- Internal light
- Double glazed removable door
- [Microwave] 10 power levels
- Child safety lock
- 8 Auto cooking programmes
- Auto-defrost

AUTO COOKING PROGRAMMES

- Milk
- Soup
- Vegetables
- Noodles
- Bread
- Fish
- Meat
- Chicken

DESIGN

- Square bar handle
- Stainless steel interior
- Green LED display

ACCESSORIES

- 1 Glass base plate

INSTALLATION

- Diagram [p.224]
- Rated load 1.5kW
- Fuse rating 10A

COOKING OUTPUT

- Microwave power 1000W



FUNCTIONS





CLASSIC BUILT-IN COMBINATION MICROWAVE



PRODUCT CODE

C CM126

DIMENSIONS

h:460mm
[inc. built-in frame]

FINISH AVAILABLE

Fingerprint resistant stainless steel

FEATURES

- 25 Litre capacity
- Auto cook menu
- Auto defrost
- Speed cooking
- Multi-stage cooking
- Child safety lock
- Minute timer [up to 95mins]
- End of cooking signal
- Push door

DESIGN

- Stainless steel front and cavity
- Mark resistant finish
- Green LED display

INSTALLATION

- Diagram [p.225]
- Rated load 2.5kW
- Fuse rating 13A

COOKING OUTPUT

- Microwave cooking 900W
- Grill 1000W
- Convection cooking 2500W

CLASSIC BUILT-IN MICROWAVE WITH GRILL



PRODUCT CODE

C CM130

DIMENSIONS

h:388mm
[inc. built-in frame]

FINISH AVAILABLE

Fingerprint resistant stainless steel

FEATURES

- 25 Litre capacity
- Microwave and grill combined cooking
- Auto cook menu
- Defrost by time or weight
- Speed cooking
- Multi stage cooking
- Child safety lock
- Minute timer [up to 95mins]
- End of cooking signal
- Push door
- Trim kit and unit installed in packaging

DESIGN

- Stainless steel front and cavity
- Mark resistant finish
- Green LED display

INSTALLATION

- Diagram [p.225]
- Rated load 2.15kW
- Fuse rating 13A

COOKING OUTPUT

- Microwave cooking 900W
- Grill 1000W

CLASSIC BUILT-IN MICROWAVE AND GRILL



CM123

PRODUCT CODE

C CM123

C CM123BK

DIMENSIONS

h:460mm
[inc. built-in frame]

FINISH AVAILABLE

Fingerprint resistant stainless steel
 Black glass

FEATURES

- 25 Litre capacity
- Auto cook menu
- Auto defrost
- Speed cooking
- Multi-stage cooking
- Child safety lock
- Minute timer [up to 95mins]
- End of cooking signal
- Push door

DESIGN

- Stainless steel front and cavity
- Mark resistant finish
- Green LED display

INSTALLATION

- Diagram [p.225]
- Rated load 1.45kW
- Fuse rating 13A

COOKING OUTPUT

- Microwave cooking 900W
- Grill 1000W

CLASSIC BUILT-IN WALL UNIT MICROWAVE AND GRILL



PRODUCT CODE

C CM120

DIMENSIONS

h:382mm
[inc. built-in frame]

FINISH AVAILABLE

Fingerprint resistant stainless steel

FEATURES

- For building into a 300mm deep wall cabinet
- 17 Litre capacity
- Auto cook menu
- Auto defrost
- Speed cooking
- Multi-stage cooking
- Child safety lock
- Minute timer [up to 95mins]
- End of cooking signal
- Push door

DESIGN

- Stainless steel front and cavity
- Mark resistant finish
- Green LED display

INSTALLATION

- Diagram [p.225]
- Rated load 1.05kW
- Fuse rating 13A

COOKING OUTPUT

- Microwave power 700W
- Grill power 1000W



CM123BK



Coffee Machines

Combining the subtle art of the barista with the very
latest in coffee machine technology.
Caple gives you perfect coffee at the touch of a button.



BARISTA STYLE COFFEE

If you like milk with your coffee, you'll also need to polish up your frothing skills. The texture depends on how the air enters the milk as you steam. You need a smooth, consistent texture where the foam and milk intertwine.

Look out for blobs of froth on top, and don't boil it. If the jug's base is too hot to touch, it means the milk's probably reached the right temperature.

For barista style lattes, cappuccinos and flat whites at the touch of a button.



THE SECRET TO GREAT COFFEE

Fantastic coffee depends on many factors. The beans you use, the way they're ground, even what temperature it is and how it is frothed. Plus, of course, finding a coffee machine that's really up to the job.

CHOOSING THE RIGHT COFFEE

Coffee beans vary in their size, shape, colour and flavour depending on the region and conditions in which they were grown. The range of unique flavours and aromas between regions is as expansive as the variety of wine available from different vineyards. It is worth experimenting with different varieties to discover a bean perfect for your palate.

Team that with one of our outstanding coffee machines and you'll have the perfect coffee every time.

MAKING A PERFECT ESPRESSO

What you're aiming for is a pour that starts out darkly coloured then turns into shades of caramel moving slowly, like honey. Caple coffee machines makes it effortless every time.



SENSE BUILT-IN COFFEE MACHINE



PRODUCT CODE

S CM465

DIMENSIONS

h:450mm

FINISH AVAILABLE

Black glass with stainless steel trim

FEATURES

- Fully automatic
- Full touch control with white LCD display
- Settings can be adjusted for making various hot drinks such as short espresso, long espresso, normal coffee, long coffee, warm milk, warm water or cappuccino [Milk/coffee mix can be customised]
- Coffee bean grinder
- Coffee grinder adjustment to modify how fine the coffee beans are ground [13 settings]
- Uses fresh coffee beans or pre-ground coffee
- 5 Drink volume adjustments to modify the amount of coffee dispensed [Espresso, small, medium, large, mug]. Each size can be adjusted to fit your favourite cup.
- 30 Auto programmes
- Programme machine to switch-on and warm up at set time
- Makes 2 cups at a time

- Milk jug
- Steam nozzle to heat and froth milk
- Hot water function
- 3 temperature settings
- 5 Coffee strength settings [Extra-strong, strong, medium, light, extra-light]
- 1.8 Litre water tank
- 200g coffee bean capacity
- 15 bar steam pressure
- Drip tray, to collect spillages
- Used coffee ground bin
- Stand-by energy saving
- Water hardness setting
- Cleaning warning
- Descale programme

ACCESSORIES

- Coffee spoon
- Descaling agent bottle
- Milk jug
- Hot water nozzle

OPTIONAL EXTRAS

- 1 Liquid descaler [DESCALER]
Visit caple.co.uk for full range

INSTALLATION

- Diagram [p.225]
- Rated load 1.35kW
- Fuse rating 10A

Features

CAPPUCCINO, JUST THE WAY YOU LIKE IT

Using the milk dispenser you can make your perfect flat white, latte or cappuccino.

For ease of use the coffee machine is set to deliver a standard cappuccino, although if you prefer more or less coffee you can adjust either to suit your preference.

COFFEE FOR TWO

Save time by making two cups of coffee simultaneously.

COMPLETE CONTROL

Produce your ideal beverage with ease by adjusting the settings to your preference. You can control everything from the size and strength to the fineness of your coffee grind. Perfection every time.



S **C** Look out for products marked with a Sense or Classic flag to easily identify the ranges.

Warming & Storage Drawers

There's nothing more disappointing than a hot meal served on a cool plate. Cuple's warming drawers keep tableware at just the right temperature for when the food is ready to be served.

Why not add a storage drawer too?
It's a convenient and stylish way to organise your coffee and wine accessories.

SENSE WARMING DRAWER



WD140BK



WD140GM

PRODUCT CODE

- S** Black glass WD140BK
- S** Gunmetal WD140GM

DIMENSIONS

h:140mm

FINISH AVAILABLE

- Black glass with stainless steel trim
- Gunmetal

FEATURES

- Fan heating
- Push/pull opening
- Dishes for a meal for 6 people take approx 30mins to heat up to 75°C
- Extremely rigid to support the weight of an appliance on top
- Maximum capacity 25kg
- 400W heating element with tangential fan
- 30 - 75°C adjustable thermostat
- Smooth slide soft-close drawer runners
- Non-slip base cover
- 90 minute cut off timer
- On/off light

INSTALLATION

- Diagram [p.226]
- Rated load 0.46kW
- Fuse rating 3A

SENSE WARMING DRAWER



PRODUCT CODE

- S** WD290BK

DIMENSIONS

h:290mm

FINISH AVAILABLE

- Black glass with stainless steel trim

FEATURES

- Fan heating
- Handle opening
- Dishes for a meal for 6 people take approx 4 - 5mins to heat up to 75°C
- Extremely rigid to support the weight of an appliance on top
- Maximum capacity 25kg
- 400W heating element with tangential fan
- 30 - 75°C adjustable thermostat
- Smooth slide soft-close drawer runners
- Non-slip base cover
- 90 minute cut off timer
- On/off light

INSTALLATION

- Diagram [p.226]
- Rated load 0.46kW
- Fuse rating 3A

CLASSIC WARMING DRAWER



WD140CLSS

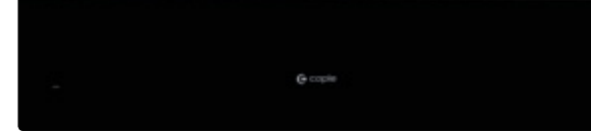

WD140CLBK

PRODUCT CODE

- C** Black glass & stainless steel WD140CLSS
- C** Black glass WD140CLBK

DIMENSIONS

h:140mm

FINISH AVAILABLE

- Black glass and stainless steel
- Black glass

FEATURES

- Fan heating
- Push/pull opening
- Dishes for a meal for 6 people take approx 4 - 5mins to heat up to 75°C
- Extremely rigid to support the weight of an appliance on top
- Maximum capacity 25kg
- 400W heating element with tangential fan
- 30 - 75°C adjustable thermostat
- Smooth slide soft-close drawer runners
- Non-slip base cover
- 90 minute cut off timer
- On/off light

INSTALLATION

- Diagram [p.226]
- Rated load 0.46kW
- Fuse rating 3A

SENSE STORAGE DRAWER



PRODUCT CODE

- S** SD140BK

DIMENSIONS

h:140mm

FINISH AVAILABLE

- Black glass with stainless steel trim

FEATURES

- Push/pull opening
- Extremely rigid to support the weight of an appliance on top
- Maximum capacity 25kg
- Smooth slide soft-close drawer runners
- Non-slip base cover

INSTALLATION

- Diagram [p.226]

Features

QUALITY INTERIOR

Precision engineered sliding runners give a high-quality feel. All models feature either a protective anti-slip mat or stylish black base.



RECOMMENDED COMBINATIONS

All our compact appliances are designed to work with a matching oven. So when thinking about your kitchen design it is important to find the right combination for your needs.



QUAD

For a contemporary look, opt for a linear design with clean, well-defined edges to showcase your appliances. Choose from our Sense or Classic range for a style to suit you.

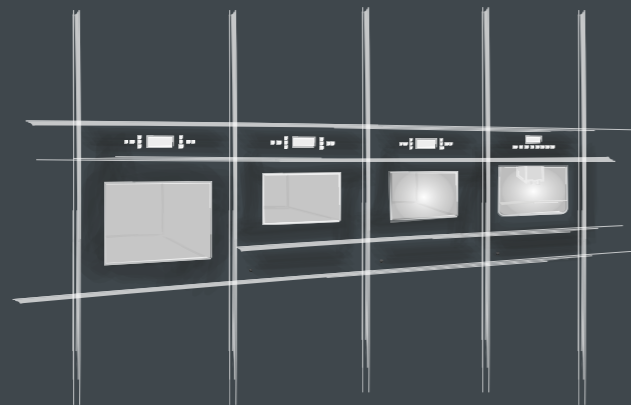

LINEAR

SENSE



C2401 ELECTRIC SINGLE PYROLYTIC OVEN



C2105 ELECTRIC SOFT CLOSE SINGLE OVEN



C2101 ELECTRIC SINGLE OVEN



C2362 ELECTRIC SINGLE OVEN



S0110 STEAM OVEN
WD140BK WARMING DRAWER



CM110 COMBINATION MICROWAVE
WD140BK WARMING DRAWER



CM108 MICROWAVE
WD140BK WARMING DRAWER



CM465 COFFEE MACHINE
WD140BK WARMING DRAWER



C2401GM ELECTRIC SINGLE
PYROLYTIC OVEN



C2105GM ELECTRIC SOFT CLOSE
SINGLE OVEN



CM110GM COMBINATION MICROWAVE
WD140GM WARMING DRAWER



S0110GM STEAM OVEN
WD140GM WARMING DRAWER

CLASSIC



C2239 ELECTRIC SINGLE PYROLYTIC OVEN



C2237 ELECTRIC SINGLE OVEN



C2234 ELECTRIC SINGLE OVEN



C2234BK ELECTRIC SINGLE OVEN



CM108SS MICROWAVE
WD140CLSS WARMING DRAWER



CM108BK MICROWAVE
WD140CLBK WARMING DRAWER

We recommend that when installing a stack or quad of products, a pair of our installation brackets [OVEN/BRACKETS2] are purchased to support the upper product ensuring a seamless fit.



Hobs

Whether you choose gas, electric or induction, Caple's advanced technology and unswerving eye for detail means real control and stylish good looks every time.



Choosing The Right Hob

MIX AND MATCH MODULAR HOBS

Any number of modules can be mixed together in any sequence. In fact, the options are almost endless [find out more on p.83].



INDUCTION

Uses leading-edge technology by creating a magnetic field between the hob and pan. They're quick, easy to use and energy efficient, vastly becoming a popular choice for professional chefs. [Find out more on p.62].



GAS

Heat is instant and the control is intuitive. You can choose either stainless steel or glass finishes.

[Find out more on p.72].



DirectHeat+

Developed with cutting-edge design and outstanding efficiency in mind, DirectHeat+ sends the heat directly towards the base of the pan via 45° inclined flame. More heat hits the base of the pan rather than escaping around the sides, therefore decreasing boiling time and bringing food to temperature more rapidly.

ELECTRIC

The smooth glass finish of a ceramic hob makes cleaning easier. They're sleek and look very contemporary, making them ideal for more modern kitchens.

[Find out more on p.69].



INDUCTION HOBS

They're hygienic, more energy-efficient,
safer and easy to use.



They work by creating a magnetic field between the hob and the pan. Heat is instant, and it's easy to control. Once you remove the pan, they cool down very quickly, which is handy if kids are about. They're more energy-efficient because they only heat the pan area itself, rather than all around it. In fact, they use around 25% less energy than some hobs.

MEMORY RECALL

After switching the hob off, it is possible to recall the last used settings with a couple of simple button presses.

AUTOMATIC PAN DETECTION

This feature detects when a suitable pan has been placed on a cooking zone, helping to eliminate the possibility of the hob being activated by a non-suitable object.

BOOSTER AND BOOSTER+

Saves time by increasing power for a quicker boiling time. Booster+ provides even further power and performance.

BRIDGE FUNCTION

Our C970i and C857i are multi zone induction hobs. They provide complete flexibility allowing the use of individual zones or the ability to combine them to create larger cooking areas.

If you cook regularly using oversized pans such as fish kettles, these hobs will handle them with ease.



ANTI-OVERFLOW, BOIL CONTROL AND ANTI-OVERHEAT

Some models include intuitive features to make cooking that little bit easier. Anti-overflow automatically cuts-off the cooking zone if liquid boils over onto the control panel.

Luckily boil control maintains a temperature of 94°C, just below boiling, whilst anti-overheat prevents the hob from overheating and damaging the elements, preserving the lifetime of your appliance.



PAUSE FUNCTION

This allows you to temporarily stop the entire hobs cooking activity and then restart it at the same settings.



LCD INDUCTION HOB



PRODUCT CODE

C970i

DIMENSIONS

↔ w: 900mm

FINISH AVAILABLE

■ Black glass

FEATURES

- Frameless with bevelled edge
- Touch control with white LCD screen
- 14 Level powder display for each zone [0-9, Bake 42°C, keep warm 70°C, boil control 93°C, Booster and booster+]
- Up to 8 cooking levels can be set at any one time
- Booster function and Booster+ on all 8 zones [p.62]

- Auto-bridge function to link zones for larger pans
- Chef Mode
- Heating area and delivered power automatically adapts to the pan
- 8 Programmable timers to set cooking duration and finishing time on each individual zone [up to 99 mins]
- Minute minder
- User programmable power levels
- Quick start short-cuts
- Adjustable brightness level for LCD screen
- Adjustable volume
- Memory recall function
- Pause function
- Child safety lock
- Residual heat indicators

- Automatic safety shut-off
- Automatic pan detection
- Anti-overheat
- Anti-over flow
- Demo mode

COOKING OUTPUT

8 Induction Zones

- 220 x [180/38mm] - 2.1kW

OPTIONAL EXTRAS

- Cast iron induction griddle [IGRIDDLE2]
- Visit caple.co.uk for full range

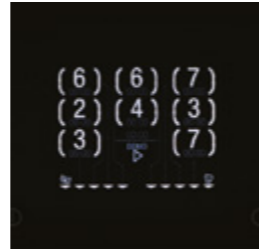

ALL 8 COOKING ZONES SHOWN



CHEF MODE

INSTALLATION

- Diagram [p.226]
- Rated load 11.1kW
- Fuse rating 40A

Features

CHEF MODE

The chef mode creates three large zones, allowing you to cook with multiple pans at various temperatures all at the same time. For example, you can fry with intense heat then slide the pan over to a low temperature zone to keep it warm whilst you concentrate on other dishes.

FEATURES

- Cast iron with food grade enamel coating
- Extra-large 840cm² cooking area [Plancha 490cm² and griddle 350cm²]
- Dishwasher safe
- Ergonomic handles

- Flat base for use on Caple induction hobs
- Suitable for use with C901i, C970i, C876i, C857i, DD935BK, DD940BK, also suitable for use on gas hobs



PRODUCT CODE

IGRIDDLE2

DIMENSIONS

↔ 460 x 260 x 33mm

WEIGHT

KG 6.5kg

SEE PAGES 62-63 FOR INDUCTION FEATURE EXPLAINED.

MULTI-ZONE INDUCTION HOB



PRODUCT CODE

C950i

DIMENSIONS

↔ Varies according to formation

FINISH AVAILABLE

■ Black glass

FEATURES

- Frameless
- Slider touch control with direct access
- Can be flush mounted or inset [all 4 zones must be installed]
- 11 Level digital power display for each zone [0-9 plus keep warm and Booster]
- Booster function on all zones [p.62]
- Programmable timer to set cooking duration and finishing time on each individual zone [up to 99 mins]
- Keep warm function
- Memory recall function
- Pause function
- Child safety lock
- Residual heat indicators

- Automatic safety shut-off
- Automatic pan detection
- Anti-overheat
- Anti-overflow

COOKING OUTPUT

4 Induction Zones

- 2 Dia. 300mm – 3kW
- 2 Dia. 270mm – 1.4kW

INSTALLATION

- Diagram [p.227]
- Rated load 7.4kW
- Fuse rating 25A

SEE PAGES 62-63 FOR INDUCTION FEATURE EXPLAINED.

RIBBON INDUCTION HOB



PRODUCT CODE

C876i

DIMENSIONS

↔ w:900mm

FINISH AVAILABLE

■ Black glass

FEATURES

- Frameless
- Central slider touch control with direct access
- White display
- Can be flush mounted or inset
- 11 Level digital power display for each zone [0-9, keep warm 70°C, and Booster]
- Booster function on 2 zones [p.62]
- Bridge function to create 1 large zone [from 2 zones]
- Programmable timer to set cooking duration and finishing time on each individual zone [up to 99 mins]
- Memory recall function
- Pause function
- Child safety lock

- Residual heat indicators
- Automatic safety shut-off
- Automatic pan detection
- Anti-overheat
- Anti-overflow

COOKING OUTPUT

4 Induction Zones

- 220mm - 3.0kW
- 190mm - 2.0kW
- 190mm - 1.4kW
- 175mm - 1.4kW

OPTIONAL EXTRAS

- Cast iron induction griddle [IGRIDDLE2]
- Visit caple.co.uk for full range

INSTALLATION

- Diagram [p.226]
- Rated load 7.1kW
- Fuse rating 25A

INDUCTION HOB



PRODUCT CODE

C901i

DIMENSIONS

↔ w:880mm

FINISH AVAILABLE

■ Black glass

FEATURES

- Frameless
- Invisi touch control with direct access
- White display
- Can be flush mounted or inset
- 11 Level digital power display for each zone [0-9, keep warm 70° and Booster]
- Booster on each zone [p.62]
- Programmable timer to set cooking duration and finishing time on each individual zone [up to 99 mins]
- Minute minder
- Automatic cooking duration display
- Memory recall function
- Chef mode

- Pan move function
- Pause
- Demo mode
- Child safety lock
- Residual heat indicators
- Automatic safety shut-off
- Automatic pan detection
- Anti-overheat
- Anti-overflow

COOKING OUTPUT

5 Induction Zones

- 1 Dia. 160mm – 1.4kW
- 1 Dia. 180mm – 1.4kW
- 1 Dia. 180mm – 2kW
- 1 Dia. 210mm – 3kW
- 1 Dia. 280mm – 3kW

OPTIONAL EXTRAS

- Cast iron induction griddle [IGRIDDLE2]
- Visit caple.co.uk for full range

INSTALLATION

- Diagram [p.226]
- Rated load 7.4kW
- Fuse rating 25A

Features

PAN MOVE FUNCTION

Allows you to move the pan from one zone to another and it will automatically pick up the selected settings from the zone the pan has been moved from [Power level and timer].

CHEF MODE

The chef mode creates three large zones, allowing you to cook with multiple pans at various temperatures all at the same time. For example, you can fry with intense heat then slide the pan over to a low temperature zone to keep it warm whilst you concentrate on other dishes.

INDUCTION HOB



PRODUCT CODE

C867i

DIMENSIONS

↔ w:780mm

FINISH AVAILABLE

□ White glass

FEATURES

- Frameless
- Audible touch controls
- Can be flush mounted or inset
- 9 Level LED power display for each zone
- 2 Booster zones [p.62]
- Programmable timer to set cooking duration and finishing time on each individual zone [up to 99 mins]

- Child safety lock
- Residual heat indicators
- Automatic safety shut-off
- Automatic pan detection
- Anti-overheat
- Anti-overflow

COOKING OUTPUT

4 Induction Zones

- 2 Dia. 170mm – 1.4kW
- 2 Dia. 210mm – 3kW

INSTALLATION

- Diagram [p.227]
- Rated load 7.4kW
- Fuse rating 32A

SEE PAGES 62-63 FOR INDUCTION FEATURE EXPLAINED.

INDUCTION HOB

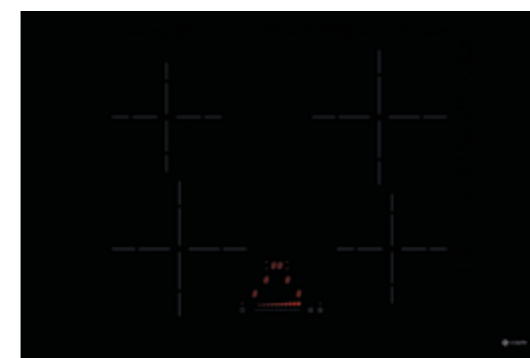

PRODUCT CODE

C864i

DIMENSIONS

↔ w:780mm

FINISH AVAILABLE

■ Black glass

FEATURES

- Black glass frameless
- Can be flush mounted
- Slider touch control with direct access
- 10 Level digital power display for each zone [0-9 plus Booster]
- Booster on each of the 4 zones [p.62]
- Individual timer for each of the 4 zones
- 99 Minute minder

- Pause function
- Child safety lock
- Residual heat indicators
- Automatic safety shut-off
- Automatic pan detection
- Anti-overheat

COOKING OUTPUT

4 Induction Zones

- 2 Dia. 215mm - 2.1kW
- 2 Dia. 175mm – 1.85kW

INSTALLATION

- Diagram [p.227]
- Rated load 7.4kW
- Fuse rating 25A

INDUCTION HOB



PRODUCT CODE

C857i

DIMENSIONS

↔ w:590mm

FINISH AVAILABLE

■ Black glass

FEATURES

- Black frameless
- Slider touch control
- Bridgeable zones
- 10 Level digital power display for each zone [0-9 plus Booster]
- Booster on each zone [p.62]
- Programmable timer for each zone to set finish time [up to 99 mins]
- Pause function
- Safety lock
- Residual heat indicators

- Automatic pan and small object detection
- Automatic safety shut-off
- Anti-overheat

COOKING OUTPUT

4 Induction Zones

- 4 Dia. 220mm – 3kW

2 Alternative Dual Zones

- 2 Dia. 220 x 400mm – 4kW

OPTIONAL EXTRAS

- Cast iron induction griddle [IGRIDDLE2]
- Visit caple.co.uk for full range

INSTALLATION

- Diagram [p.227]
- Rated load 7.0kW
- Fuse rating 32A

Features

BRIDGEABLE ZONES

The C857i zones provide complete flexibility in allowing either use of 4 individual zones, the option to combine zones into 2 larger zones for use with oversized pans or fish kettles.

SEE PAGES 62-63 FOR INDUCTION FEATURE EXPLAINED.



INDUCTION HOBS



PRODUCT CODE

C846i

DIMENSIONS

↔ w:590mm

FINISH AVAILABLE

■ Black glass

FEATURES

- Frameless
- Slider touch control with direct access
- 10 Level digital power display for each zone [0-9 plus Booster]
- Booster on each zone [p.62]
- 99 Minute timer
- Child safety lock
- Residual heat indicators
- Automatic safety shut-off
- Automatic pan detection
- Programmable timer for each zone to set finish time [up to 99 mins]

COOKING OUTPUT

4 Induction Zones

- 2 Dia. 140mm – 1.5kW with Booster
- 2 Dia. 220mm – 2.6kW with Booster

INSTALLATION

- Diagram [p.227]
- Rated load 7kW
- Fuse rating 32A



PRODUCT CODE

C843i

DIMENSIONS

↔ w:590mm

FINISH AVAILABLE

■ Black glass

FEATURES

- Frameless
- Touch control
- 9 Level digital power display for each zone
- 99 Minute timer
- Child safety lock
- Residual heat indicators
- Automatic safety shut-off
- Automatic pan detection
- Programmable timer for one zone to set finish time [up to 99 mins]

COOKING OUTPUT

4 Induction Zones

- 2 Dia. 140mm - 1.5kW
- 2 Dia. 180mm – 2kW

INSTALLATION

- Diagram [p.227]
- Rated load 7.2kW
- Fuse rating 32A

INDUCTION HOB - 13 AMP



PRODUCT CODE

C840i

DIMENSIONS

↔ w:590mm

FINISH AVAILABLE

■ Black glass

FEATURES

- Frameless
- Touch control
- 9 Level digital power display
- 99 Minute timer
- Child safety lock
- Residual heat indicators
- Automatic safety shut-off
- Automatic pan detection
- Anti-overheat
- Supplied with a 13A plug for easy installation in any kitchen
- Programmable timer for one zone to set finish time [up to 99 mins]

COOKING OUTPUT

4 Induction Zones

- 2 Dia. 180mm – 1.5kW
- 2 Dia. 180mm – 2kW

INSTALLATION

- Diagram [p.227]
- Rated load 3kW
- Fuse rating 13A



PLEASE NOTE: The C840i induction hob achieves a 13A connection by restricting the maximum load to 3kW, this is done by cleverly limiting the combined zones to a maximum power level sum of 12. For example if you had boiling water on power level 6 on one zone you could cook rice on power level 4 and gently warm food on level 2 on a third zone.

SEE PAGES 62-63 FOR INDUCTION FEATURE EXPLAINED.



The Power of Electric Hobs

Caple's electric hobs are engineered with performance, versatility and ease of use in mind.

Each hob has four separate zones offering different sizes, with individual lights that glow when activated. Touch control models set seamlessly into the worktop, but if you prefer more traditional operation opt for one of the dial control models.

The smooth black glass makes cleaning easy and thanks to minimalist styling our frameless ceramic models will fit into any type of kitchen.

ELECTRIC CERAMIC HOBS



PRODUCT CODE

C824C

DIMENSIONS

w:780mm

FINISH AVAILABLE

Black glass

FEATURES

- Frameless
- Can be flush mounted
- Touch control
- 10 Level digital power display [0-9 + keep warm]
- 4 Quick heat boosters
- Programmable timer for each zone [up to 99mins] to set finish time
- Minute timer
- A timer for each cooking zone
- Residual heat indicators
- Child safety lock
- Overflow protection
- Automatic safety shut-off

COOKING OUTPUT

4 Ceramic Plates

- 1 dia. 135mm/210mm – 1.0kW - 2.2kW
- 1 dia. 110mm/180mm – 0.7kW - 1.7kW
- 2 dia. 145mm – 1.2kW

INSTALLATION

- Diagram [p.227]
- Rated load 6.3kW
- Fuse rating 25A



ELECTRIC CERAMIC HOB



PRODUCT CODE

C808C

DIMENSIONS

w:590mm

FINISH AVAILABLE

Black glass

FEATURES

- Frameless
- Indicator lights for each zone
- Residual heat indicators

COOKING OUTPUT

4 Ceramic Plates

- 2 Dia. 200mm – 1.8kW
- 2 Dia. 165mm – 1.2kW

INSTALLATION

- Diagram [p.227]
- Rated load 6kW
- Fuse rating 32A

ELECTRIC SEALED PLATE HOB



PRODUCT CODE

C605E

DIMENSIONS

w:580mm

FINISH AVAILABLE

Stainless steel

FEATURES

- Neon indicator lights
- 6 Power levels

COOKING OUTPUT

4 Sealed Plates

- 1 Redspot plate: Dia. 188mm – 2kW
- 2 Regular plates: Dia. 155mm – 1kW
- 1 Regular plate: Dia. 188mm – 1.5kW

INSTALLATION

- Diagram [p.227]
- Rated load 5.5kW
- Fuse rating 25A



PRODUCT CODE

C815C

DIMENSIONS

w:590mm

FINISH AVAILABLE

Black glass

FEATURES

- Frameless
- Touch control
- 9 Level digital power display
- 99 Minute timer
- Residual heat indicators
- Child safety lock
- Automatic safety shut-off

COOKING OUTPUT

4 Ceramic Plates

- 2 Dia. 200mm – 1.8kW
- 2 Dia. 165mm – 1.2kW

INSTALLATION

- Diagram [p.227]
- Rated load 6kW
- Fuse rating 30A

Gas-on-Glass Hobs

If you're looking for a hob that combines contemporary design with power and functionality, this one ticks all the boxes.

That elegant glass surface doesn't just look stunning, it makes your hob simple to clean, while linked cast iron pan supports let you easily transfer pans across burners or away from the heat.

All burners are Flame Safe, so if a flame is extinguished for any reason, the gas supply is cut straight away. Some hobs also feature a responsive triple ring burner for extra powerful cooking.



GAS-ON-GLASS HOB

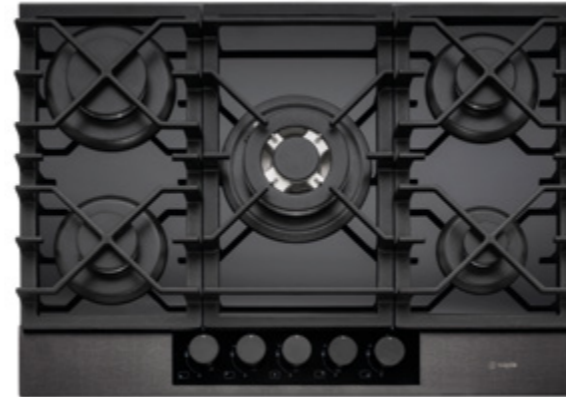

PRODUCT CODE

C887G

DIMENSIONS

↔ w:700mm

FINISH AVAILABLE

■ Gunmetal and black glass

FEATURES

- Black glass, with gunmetal front panel
- Flame safety device
- Cast iron pan supports
- Auto electronic ignition
- LPG jets included

COOKING OUTPUT

5 Gas Burners

- 1 Triple ring burner: 3kW
- 1 Rapid burner: 2.40kW
- 2 Semi-rapid burners 1.88kW
- 1 Simmer burner: 0.9kW

OPTIONAL EXTRAS

- Cast iron induction griddle [IGRIDDLE2]
- Visit caple.co.uk for full range

INSTALLATION

- Diagram [p.228]
- Fuse rating 3A

GAS-ON-GLASS HOB

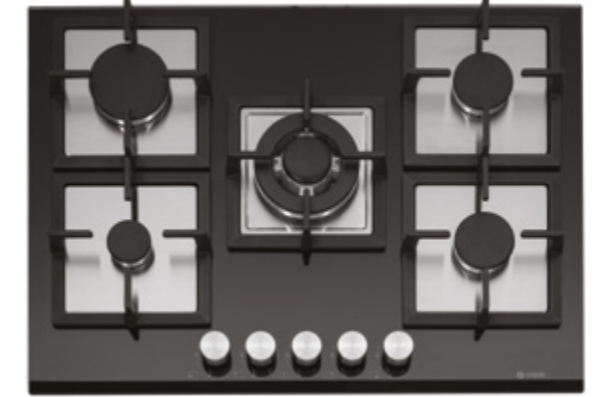

PRODUCT CODE

C871GBK

DIMENSIONS

↔ w:680mm

FINISH AVAILABLE

■ Black glass

FEATURES

- Black glass, with bevelled front edge
- Flame safety device
- Cast iron pan supports
- Auto electronic ignition
- LPG jets included

COOKING OUTPUT

5 Gas Burners

- 1 Triple ring burner: 3kW
- 1 Rapid burner: 2.40kW
- 2 Semi-rapid burners 1.88kW
- 1 Simmer burner: 0.9kW

OPTIONAL EXTRAS

- Cast iron induction griddle [IGRIDDLE2]
- Visit caple.co.uk for full range

INSTALLATION

- Diagram [p.228]
- Fuse rating 3A

TOUCH PRECISION CONTROLS

Touch controls set into black tempered glass look fabulous, but beauty is more than skin deep.

Advanced digital technology gives you nine precise power levels on each burner, so they also offer an exceptional level of control.



Developed with cutting-edge design and outstanding efficiency in mind, DirectHeat+ sends the heat directly towards the base of the pan via 45° inclined flame. More heat hits the base of the pan rather than escaping around the sides, therefore decreasing boiling time and bringing food to temperature more rapidly.

GUNMETAL HOB

At Caple, we know how important it is to co-ordinate colours in the kitchen, which is why the gunmetal trend continues with the C887G gas hob. The sleek black glass and cool gunmetal control work together in perfect harmony.



TOUCH CONTROL GAS-ON-GLASS HOBS



PRODUCT CODE

C981G

DIMENSIONS

↔ w:790mm

FINISH AVAILABLE

■ Black glass

FEATURES

- Touch control
- 9 Level digital power display for each zone
- End of cooking timer
- Child safety lock
- Residual heat indicators
- Flame safety device with auto restart
- Cast iron pan supports
- Auto electronic ignition
- LPG jets included

COOKING OUTPUT

5 Gas Burners

- 1 Triple ring burner: 4kW
- 1 Rapid burner: 3kW
- 2 Semi-rapid burners: 1.75kW
- 1 Simmer burner: 1kW

OPTIONAL EXTRAS

- Cast iron induction griddle [IGRIDDLE2]
- Visit caple.co.uk for full range

INSTALLATION

- Diagram [p.228]
- Fuse rating 3A



PRODUCT CODE

C1081G

DIMENSIONS

↔ w:1000mm

FINISH AVAILABLE

■ Black glass

FEATURES

- Touch control
- 9 Level digital power display for each zone
- End of cooking timer
- Child safety lock
- Residual heat indicators
- Flame safety device with auto restart
- Cast iron pan supports
- Auto electronic ignition
- LPG jets included

COOKING OUTPUT

4 Gas Burners

- 1 Triple ring burner: 4kW
- 1 Rapid burner: 3kW
- 1 Semi-rapid burner: 1.75kW
- 1 Simmer burner: 1kW

OPTIONAL EXTRAS

- Cast iron induction griddle [IGRIDDLE2]
- Visit caple.co.uk for full range

INSTALLATION

- Diagram [p.228]
- Fuse rating 3A

GAS-ON-GLASS HOBS

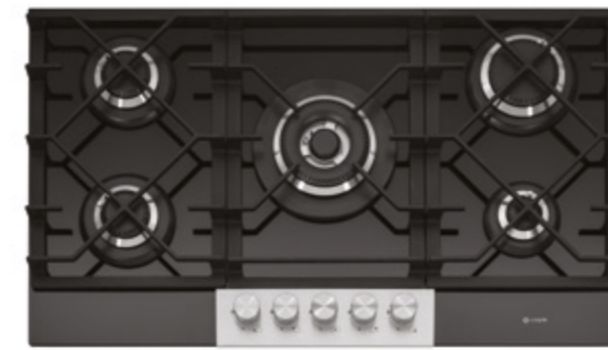

C789G



C787G



C786G

PRODUCT CODE

C789G

C787G

C786G

DIMENSIONS

↔ w:874mm	C789G
↔ w:700mm	C787G
↔ w:584mm	C786G

FINISH AVAILABLE

■ Black glass with stainless steel control panel

FEATURES

- DirectHeat+
- Flame safety device
- Cast iron pan supports
- Auto electronic ignition
- LPG jets included

COOKING OUTPUT

5 Gas Burners

[C789G and C787G]

- 1 Triple ring burner: 4.2kW
- 1 rapid burner: 2.7kW
- 2 semi-rapid burners: 1.75kW
- 1 simmer burner: 1.0kW

4 Gas Burners [C786G]

- 1 Triple ring burner: 3.6kW
- 2 semi-rapid burners: 1.75kW
- 1 simmer burner: 1.0kW

OPTIONAL EXTRAS

- Cast iron induction griddle [IGRIDDLE2]
- Visit caple.co.uk for full range

INSTALLATION

- Diagram [p.228]
- Fuse rating 3A

Features



Developed with cutting-edge design and outstanding efficiency in mind, DirectHeat+ sends the heat upwards directly towards the base of the pan via 45° inclined flame. More heat hits the base of the pan rather than escaping around the sides, therefore decreasing boiling time and bringing food to temperature more rapidly.



GAS-ON-GLASS HOBS



C769G



C759G



C739G

PRODUCT CODE

C769G

C759G

C739G

DIMENSIONS

↔	w:900mm	C769G
	w:750mm	C759G
	w:600mm	C739G

FINISH AVAILABLE

- Black glass with stainless steel

FEATURES

- Stainless steel front trim
- Flame safety device
- Cast iron pan supports
- Auto electronic ignition
- LPG jets included

COOKING OUTPUT

5 Gas Burners [C769G and C759G]

- 1 Triple ring burner: 3.8kW
- 1 Rapid burner: 3kW
- 2 Semi-rapid burners: 1.75kW
- 1 Simmer burner: 1kW

4 Gas Burners [C739G]

- 1 Rapid burner: 3kW
- 2 Semi-rapid burners: 1.75kW
- 1 Simmer burner: 1kW

OPTIONAL EXTRAS

- Cast iron induction griddle [IGRIDDLE2]
- Visit caple.co.uk for full range

INSTALLATION

- Diagram [p.228]
- Fuse rating 3A



GAS-ON-GLASS HOBS



C744G



C944G

PRODUCT CODE

C744G

C944G

DIMENSIONS

↔	w:580mm	C744G
	w:750mm	C944G

FINISH AVAILABLE

- Black glass

FEATURES

- Flame safety device
- Cast iron pan supports
- Auto electronic ignition
- LPG jets included

COOKING OUTPUT

4 Gas Burners [C744G]

- 1 Triple ring burner: 3.00kW
- 2 semi-rapid burners: 1.88kW
- 1 simmer burner: 0.9kW

5 Gas Burners [C944G]

- 1 Triple ring burner: 3kW
- 1 Rapid burner: 2.40kW
- 2 Semi-rapid burners 1.88kW
- 1 Simmer burner: 0.9kW

OPTIONAL EXTRAS

- Cast iron induction griddle [IGRIDDLE2]
- Visit caple.co.uk for full range

INSTALLATION

- Diagram [p.228]
- Fuse rating 3A



Flush Mounted Gas Hobs

The look says it all. Designed to fit perfectly with the clean and uncluttered lines of a modern kitchen, this innovative hob offers more than superb styling, it provides real practical advantages too.

CLEAN LINES

With their elegant low-profile recessed design and smart styling, these superb hobs maintain the clean linear look of your kitchen. They're thoroughly practical too - the hob's recess catches any spills and makes it easy to wipe down and clean.



Flush mounted or inset into your worktop, the recessed hob is the ideal match for solid surface worktop materials like marble, granite or slate. Flat cast iron supports mean that you can move pans across the hob effortlessly, and Caple's Flame Safe feature gives you peace of mind – if a flame goes out – the gas supply is cut almost immediately.

Developed with cutting-edge design and outstanding efficiency in mind, DirectHeat+ sends the heat directly towards the base of the pan via 45° inclined flame. More heat hits the base of the pan rather than escaping around the sides, therefore decreasing boiling time and bringing food to temperature more rapidly.

FLUSH MOUNTED GAS HOB



PRODUCT CODE

C772G

DIMENSIONS

w:750mm

FINISH AVAILABLE

Stainless steel and black enameled inner

FEATURES

- DirectHeat+
- Can be flush mounted or inset
- Flame safety device
- Cast iron pan supports
- Auto electronic ignition
- LPG jets included

COOKING OUTPUT

5 Gas Burners

- 1 Triple ring burner: 4kW
- 1 Rapid burner: 3kW
- 2 Semi-rapid burners: 1.75kW
- 1 Simmer burner: 1kW

OPTIONAL EXTRAS

- Cast iron induction griddle [IGRIDDL2]
- Visit caple.co.uk for full range

INSTALLATION

- Diagram [p.229]
- Fuse rating 3A

FLUSH MOUNTED GAS HOB



PRODUCT CODE

C972G

DIMENSIONS

w:890mm

FINISH AVAILABLE

Stainless steel

FEATURES

- Can be flush mounted or inset
- Flame safety device
- Cast iron pan supports
- Auto electronic ignition
- LPG jets included

COOKING OUTPUT

5 Gas Burners

- 1 Triple ring burner: 3.8kW
- 1 Rapid burner: 3kW
- 2 Semi-rapid burners: 1.75kW
- 1 Simmer burner: 1kW

OPTIONAL EXTRAS

- Cast iron induction griddle [IGRIDDL2]
- Visit caple.co.uk for full range

INSTALLATION

- Diagram [p.229]
- Fuse rating 3A

FLUSH MOUNTED GAS HOB



PRODUCT CODE

C1072G

DIMENSIONS

w:1100mm

FINISH AVAILABLE

Stainless steel

FEATURES

- Can be flush mounted or inset
- Flame safety device
- Cast iron pan supports
- Auto electronic ignition
- LPG jets included

COOKING OUTPUT

4 Gas Burners

- 1 Triple ring burner: 4kW
- 1 Rapid burner: 3kW
- 1 Semi-rapid burner: 1.75kW
- 1 Simmer burner: 1kW

OPTIONAL EXTRAS

- Cast iron induction griddle [IGRIDDL2]
- Visit caple.co.uk for full range

INSTALLATION

- Diagram [p.229]
- Fuse rating 3A

Low Profile Gas Hobs



LOW PROFILE GAS HOBS



C873G



C866G



C848G

PRODUCT CODE

C873G
C866G
C848G

DIMENSIONS

	w:890mm	C873G
	w:750mm	C866G
	w:590mm	C848G

FINISH AVAILABLE

 Stainless steel

FEATURES

- Flame safety device
- Cast iron pan supports
- Auto electronic ignition
- LPG jets included

COOKING OUTPUT

5 Gas Burners [C873G and C866G]

- 1 Triple ring burner: 3.8kW
- 1 Rapid burner: 3kW
- 2 Semi-rapid burners: 1.75kW
- 1 Simmer burner: 1kW

4 Gas Burners [C848G]

- 1 Rapid burner: 3kW
- 2 Semi-rapid burners: 1.75kW
- 1 Simmer burner: 1kW

OPTIONAL EXTRAS

- Cast iron induction griddle [IGRIDDLE2]
- Visit caple.co.uk for full range

INSTALLATION

- Diagram [p.229]
- Fuse rating 3A

Those who've cooked on gas rarely go back to any other hob. Gas rings provide immediate heat, and are intuitive, reliable, and super-easy to control.

Unrivalled performance and looks, coupled with ease of fitting. Caple low profile hobs are designed to sit on top of the work surface with the smallest of edges.

Our gas hobs come in sleek stainless steel or smooth finishes, and look fantastic in contemporary or classic kitchens.

They give you the appearance of a professional kitchen with added Caple refinement.

GAS HOBS



C774G



C767G



C749G

PRODUCT CODE

C774G

C767G

C749G

DIMENSIONS

↔ w:860mm	C774G
↔ w:750mm	C767G
↔ w:590mm	C749G

FINISH AVAILABLE

Stainless steel

FEATURES

- Flame safety device
- Cast iron pan supports
- Auto electronic ignition
- LPG jets included

COOKING OUTPUT

5 Gas Burners [C774G and C767G]

- 1 Triple ring burner: 3.3kW
- 1 Rapid burner: 3kW
- 2 Semi-rapid burners: 1.75kW
- 1 Simmer burner: 1kW

4 Gas Burners [C749G]

- 1 Rapid burner: 3kW
- 2 Semi-rapid burners: 1.75kW
- 1 Simmer burner: 1kW

OPTIONAL EXTRAS

- Cast iron induction griddle [IGRIDDLE2]
- Visit caple.co.uk for full range

INSTALLATION

- Diagram [p.229]
- Fuse rating 3A

GAS HOB



C706G

PRODUCT CODE

C706G

DIMENSIONS

↔ w:580mm

FINISH AVAILABLE

Stainless steel

FEATURES

- Flame safety device
- Enamelled pan supports
- Auto electronic ignition
- LPG jets included

COOKING OUTPUT

- #### 4 Gas Burners
- 1 Triple ring burner: 3.0kW
 - 2 Semi-rapid burners: 1.88kW
 - 1 Simmer burner: 0.9kW

INSTALLATION

- Diagram [p.229]
- Fuse rating 3A



Modular Hobs

Now you can build the perfect hob for your needs. Combine gas, electric, induction and modular extraction for a truly bespoke solution that's sure to impress.

Combine two, three, four or more modules, of any type and in any sequence. Introduce induction cooking into your kitchen by combining it with gas or electric, or wow with tepan - perfect for flash frying.

When coupled with powerful downdraft extraction it offers a clean, fully integrated design throughout – bespoke and beautiful.

TEPAN HOB



PRODUCT CODE

C995T

DIMENSIONS

w:380mm

FINISH AVAILABLE

Stainless steel with black glass

FEATURES

- Black glass frame
- Automatic stop and temperature limiter
- Residual heat indicator
- Maximum temperature 240°C

COOKING OUTPUT

1 Cooking Zone

- 380 x 380mm – 2.5kW

INSTALLATION

- Diagram [p.229]
- Rated load 2.5kW
- Fuse rating 16A

INDUCTION MODULAR HOB

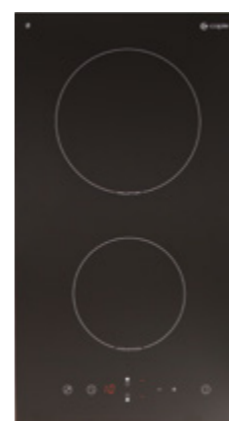

PRODUCT CODE

C994i

DIMENSIONS

w:288mm

FINISH AVAILABLE

Black glass

FEATURES

- Frameless
- Audible touch control
- 9 Level digital power display for each zone
- Timer [up to 99mins] with audible alarm and auto switch-off

- Automatic stop and temperature limiter
- Child safety lock
- Residual heat indicators
- Automatic pan detection

COOKING OUTPUT

2 Induction Zones

- 1 Dia. 140mm – 1.5kW
- 1 Dia. 180mm – 2kW

INSTALLATION

- Diagram [p.230]
- Rated load 3.5kW
- Fuse rating 16A

INDUCTION MODULAR HOB



PRODUCT CODE

C996i

DIMENSIONS

w:380mm

FINISH AVAILABLE

Black glass

FEATURES

- Polished aluminium trim
- Touch control
- 9 Level digital power display for each zone
- Booster function on both zones to access maximum temperature quickly

- Timer [up to 99mins] with audible alarm and auto switch-off
- Automatic stop and temperature limiter
- Child safety lock
- Residual heat indicators
- Automatic pan detection

COOKING OUTPUT

2 Induction Zones

- 1 Dia. 200mm – 2kW [with 3kW Booster]
- 1 Dia. 160mm – 1.6kW

INSTALLATION

- Diagram [p.229]
- Rated load 3.6kW
- Fuse rating 16A

ELECTRIC CERAMIC MODULAR HOB

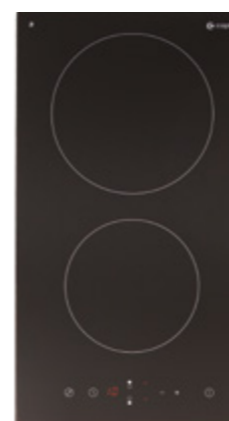

PRODUCT CODE

C892C

DIMENSIONS

w:288mm

FINISH AVAILABLE

Black glass

FEATURES

- Frameless
- Audible touch control
- 9 Level digital power display for each zone
- Timer [up to 99mins] with audible alarm and auto switch-off
- Automatic stop and temperature limiter
- Child safety lock
- Residual heat indicators

COOKING OUTPUT

2 Ceramic Plates

- 1 Dia. 165mm – 1.2kW
- 1 Dia. 200mm – 1.8kW

INSTALLATION

- Diagram [p.230]
- Rated load 3.3kW
- Fuse rating 16A

GAS-ON-GLASS MODULAR HOB



PRODUCT CODE

C993G

DIMENSIONS

w:380mm

FINISH AVAILABLE

Black glass

FEATURES

- Polished aluminium trim
- Flame safety device
- Cast iron pan support

- Auto electronic ignition
- LPG jets included

COOKING OUTPUT

2 Gas Burners

- 1 Rapid burner: 3kW
- 1 Semi-rapid burner: 1.75kW

INSTALLATION

- Diagram [p.229]
- Fuse rating 3A



Induction Downdraft Extractors

SEAMLESS INTEGRATION, AND UNMISTAKABLE STYLING.

As the name suggests induction downdrafts combine intuitive induction hobs with the added benefit of integrated, powerful downdraft extraction.

SPACE SAVING INSTALLATION

Unique space-saving installation can be used with minimal ducting and the motor located behind the plinth which means you can still utilise the cabinets directly underneath the hob.

For installation see p. 230-231.

The DD940BK gives you the option to use Plasma technology allowing you to recirculate the air with very efficient odour removal process.



The powerful, ultra quiet motor draws the cooking vapour through the 12 stage filter, removing grease and moisture.



Discreetly positioned behind the plinth, the motor draws the air through the ducting, on towards the filters.

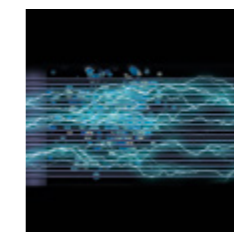

The first filter creates the 4th stage of matter, Plasma. A trusted technology developed by the German university of Göttingen. The Plasma removes 95% of the odours passing through it.



A carbon filter removes any remaining odours and has a life span of 5 years or more when used with a plasma filter.



Clean air is then recirculated back into the room.



INDUCTION DOWNDRAFT EXTRACTOR

PRODUCT CODE

DD940BK

DIMENSIONS

↳ w:900mm

PERFORMANCE

e Energy class A
 Fluid dynamic efficiency A
 Grease absorption A
 Annual Consumption
 41.5kWh/yr
 Max. extraction 585m³/h
 Max. noise level 61dB

FINISH AVAILABLE

■ Black glass

GENERAL FEATURES

- 5 Year guarantee

FEATURES

Hob

- Frameless
- Can be flush mounted
- Slider touch control
- Large cooking area
- 10 Power level digital display for each zone [0-9 plus booster]
- Booster function on all zones, including Auto Boost mode
- Bridge function to combine 2 zones
- Timer for each zone / minute minder
- Memory recall function
- 3 preset temperatures settings [bake 42°C, keep warm 70°C, boil control 92°C]

Pause function

- Child safety lock
- Residual heat indicators
- Automatic safety shut-off
- Anti-overheat
- Auto pan detection

Downdraft

- Touch control
- 4 speeds
- Auto timer, 10 - 60 minute timer
- Aluminium grease filters
- Ducting spigot size 150mm 
- Plinth motor included
- Optional plasma filter

COOKING OUTPUT

- 190 X 220mm - 3.7kW

OPTIONAL EXTRAS

- Plasma filter [PLASMABOX]
 - Recirculation kit [CAP57CF]
 - Removable grille [GRILLE/DD940BK]
 - Cast iron induction griddle [IGRIDDLE2]
- Visit caple.co.uk for full range

INSTALLATION

- Space saving installation diagram [p.230]
- Venting Kits [p.143]

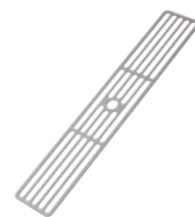

GRILLE/DD940BK

▶ **PLASMA EXPLAINED** Watch our plasma video online at www.caple.co.uk



INDUCTION DOWNDRAFT EXTRACTOR

PRODUCT CODE

DD935BK

DIMENSIONS

↳ w:780mm

PERFORMANCE

e Energy class B
 Max. extraction 655m³/h
 [speed 1 286m³/h,
 speed 2 374m³/h,
 speed 3 497m³/h,
 speed 4 655m³/h]

FINISH AVAILABLE

■ Black glass

FEATURES

Hob

- Black glass with flush black downdraft grille
- Frameless
- Slider touch controls
- 13 power levels [0-9, bake 42°C, keep warm 70°C, boil control 94°C and Booster]
- Booster function on all zones
- Timer function
- Keep warm function
- Pause and memory recall function
- Bridge function
- Automatic heat-up function
- Child safety lock
- Residual heat indicators
- Anti-overheat protection
- Automatic safety shut-off
- Auto pan detection

Downdraft

- Touch control
- 4 Speeds
- Auto timer, switch-off after 10mins
- Aluminium grease filter
- Ducting spigot size 150mm 
- Motor included
- Recirculation kit available

COOKING OUTPUT

4 Induction Zones
 - 184x220mm – 3.7kW

OPTIONAL EXTRAS

- Washable charcoal filter [CAP76CF]
 - Removable gunmetal grille [GRILLE/DD935GM]
 - Cast iron induction griddle [IGRIDDLE2]
- Visit caple.co.uk for full range

INSTALLATION

- Space saving installation diagram [p.231]
- Venting Kits [p.143]

Features



GRILLE/DD935GM

Co-ordinate colours in the kitchen with a gunmetal grille.



Extraction

A well-engineered extractor hood does more than just help to capture odours from your kitchen. Be bold, and use it as a visual focal point too.

Choosing the Perfect Hood

We've designed one for every kind of kitchen. Striking colours, exceptional finishes, and plenty of functionality.

Extractors and hoods are designed to remove cooking odours, moisture and grease from the cooking environment. The extractor continually removes and filters the air when on. It then, either, returns the filtered air back in to the room or expels it through an external vent. The greater the extraction rate the more effectively this is done.



GETTING THE BEST FROM YOUR HOOD

Try switching on the extractor or hood 15 minutes before you begin cooking. This creates kinetic air circulation within the kitchen carrying the air out more effectively. It is also advisable to keep it running for a further 15 minutes after you have finished cooking.

You can sit down and enjoy the results of your culinary skills whilst your Caple extractor or hood gets on with its job.

Once you have chosen your extractor, it is important to pair it with the correct venting. It is essential the stated ducting diameter is used, we also recommend rigid ducting to ensure you get the maximum performance. Not only will this prolong the life of your extractor, it will also improve efficiency.



If you choose to vent your extractor to the outside world, look out for the venting symbol shown to assist you in choosing the correct product. Please see page 142-143 for more information.



INDUCTION DOWNDRAFT

This award-winning category of extraction is ideal for open plan living. The powerful extraction eradicates cooking odours from the room and the minimal aesthetics discreetly blends into the worktop for a seamless look. See our range of Induction downdraft hobs in the hob section, pages 86-89



DOWNDRAFT EXTRACTORS

This type of counter extractor is installed behind or alongside your hob. When you need it, just press the button and it glides up in to position.



CEILING HOODS

They're unobtrusive and they save you space too. You can choose different motors and have complete control over extraction rates.



ISLAND HOODS

Better suited to larger kitchens. You can suspend them over a central island unit to make a stunning focal point.



WALL CHIMNEY HOODS

Available in all kinds of sizes, styles and finishes. Great for a dramatic focal point.



BUILT-UNDER HOODS

Ideal for smaller kitchens. They're cleverly integrated into the underside of kitchen units.



INTEGRATED HOODS

Discreetly hidden behind kitchen furniture, and pulled out when needed.



CONVENTIONAL HOODS

This type fits neatly beneath a kitchen unit, with controls usually found on the front.

Downdraft Extractors



Caple downdraft extractors are the epitome of intelligent thinking in kitchen design. With an ingenious under-counter installation, wall space is kept clear and when integrated into an island unit, views across the kitchen remain uncluttered.

A downdraft extractor can be housed either behind or alongside a hob, in an island unit or within a base against a wall.

FLUSH FITTING

Fitting elegantly into the surface until activated, it rises out of the worktop beyond the height of the pans to extract odours directly from the cooking area.

These smart extractors deliver high extraction rates and give you a choice of motors and motor positioning options to suit your kitchen design. For example, your motor could be situated under the floor, on an external wall or in a cupboard, so noise can be virtually eliminated [p.108-113]. With real versatility, our downdraft extractors can expel air via ducting or recirculate it using charcoal filters.

SLEEK STYLING

Most of our downdrafts feature touch control technology and are designed to complement the appliances within the Sense range.

SMOOTH OPERATOR

At the touch of a button, the DD925CO rises smoothly up from its flush, retracted position.

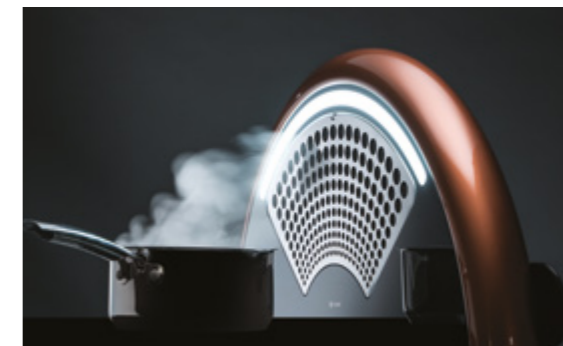

MOTOR CHOICES

Downdraft extractors will need to be purchased with a motor. For the full range please see p.108-109



INVISIBLE MOTOR

The DDMEXT28 is designed to be easily and discreetly installed behind the plinth without the requirement of ducting to the outside of the building. For more details see p.109.

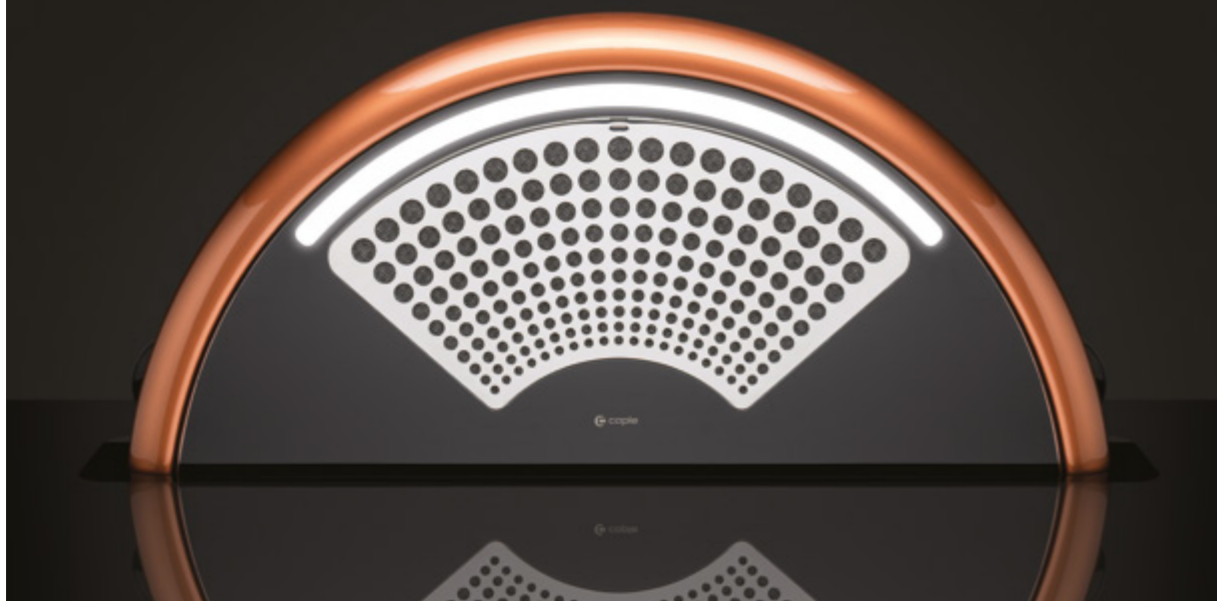

NOSTA

DOWNDRAFT EXTRACTOR WITH LIGHT

PRODUCT CODE

DD925CO

DIMENSIONS

↔ w:880mm

PERFORMANCE

e Energy class A-C
For energy and performance see p.110 - 113

FINISH AVAILABLE

■ Black glass with copper

FEATURES

- For use with gas or electric hobs
- 4 Speeds [inc. Boost function]
- Auto timer, switch-off after 10mins
- 14W white LED light

- Remote control operated
- Polished stainless steel grease filters
- Ducting spigot size 150mm
- Motor not included
- Recirculation kit available

MOTOR CHOICES

- Downdraft extractors will need to be purchased with a motor. For the full range please see p.108 - 109.

OPTIONAL EXTRAS

- Recirculation kit [CAP68CF - only for use with motors DDMEXT11 and DDMEXT28]
Visit caple.co.uk for full range

INSTALLATION

- Diagram [p.231]
- Venting Kits [p.143]
- The electric's box must be located at least 650mm from the hob



DD925CO CLOSED

DOWNDRAFT EXTRACTOR WITH LIGHT

PRODUCT CODE

DD120BK

DIMENSIONS

↔ w:1175mm

PERFORMANCE

e Energy class A-C
For energy and performance see p.110 - 113

FINISH AVAILABLE

■ Black glass with stainless steel

FEATURES

- Illuminated touch controls
- For use with gas or electric hobs
- Perimetrical extraction for reduced noise and increased pressure resulting in improved motor performance
- 4 Speeds [inc.Boost function]

- Auto timer, switch-off after 10mins
- Bright 21W white neon light
- Aluminium grease filters
- Required ducting size 150mm
- Motor not included
- Recirculation kit available

MOTOR CHOICES

- Downdraft extractors will need to be purchased with a motor. For the full range please see p.108 - 109.

OPTIONAL EXTRAS

- Recirculation kit [CAP69CF - only for use with motors DDMEXT11 and DDMEXT28]
Visit caple.co.uk for full range

INSTALLATION

- Diagram [p.231]
- Venting Kits [p.143]
- The electric's box must be located at least 650mm from the hob



Venting choices

Ensure you purchase the correct venting for your Caple extractor. For the full range please see p.142 - 143

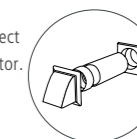



FLUSH DOWNDRAFT EXTRACTORS WITH LIGHT

PRODUCT CODE

Stainless Steel	DD911SS
White Glass	DD911WH
Black Glass	DD911BK



DIMENSIONS

↔ w:875mm

PERFORMANCE

e Energy class A-C
For energy and performance see p.110 - 113

FINISH AVAILABLE

-  Stainless steel
-  White glass with stainless steel
-  Black glass with stainless steel

FEATURES

- Illuminated touch control
- For use with gas or electric hobs
- Perimetrical extraction for reduced noise and increased pressure resulting in improved motor performance
- 4 Speeds [inc. Boost function]
- Auto timer, switch-off after 10mins
- Bright 14W white neon light
- Aluminium grease filters
- Required ducting size 150mm 
- Motor not included
- Recirculation kit available

MOTOR CHOICES

- Downdraft extractors will need to be purchased with a motor. For the full range please see p.108 - 109.

OPTIONAL EXTRAS

- Recirculation kit [CAP43CF - only for use with motors DDMEXT11 and DDMEXT28]
Visit caple.co.uk for full range

INSTALLATION

- Diagram [p.232]
- Venting Kits [p.143]
- The electrics box must be located at least 650mm from the hob



PUSH DOWNDRAFT EXTRACTOR WITH LIGHT



PRODUCT CODE

DD901BK

DIMENSIONS

↔ w:810mm

PERFORMANCE

e Energy class B-C
For energy and performance see p.110 - 113

FINISH AVAILABLE

-  Black glass with stainless steel

FEATURES

- Electronic push button controls
- Perimetrical extraction for reduced noise and increased pressure resulting in improved motor performance
- For use with gas or electric hobs
- 4 Speeds [inc. Boost function]
- Auto timer, switch-off after 10mins
- 2 x 3.9W white LED lights
- Stainless steel and aluminium grease filters
- Required ducting size 150mm 
- Motor not included
- Recirculation kit available



Venting choices

Ensure you purchase the correct venting for your Caple extractor. For the full range please see p.142 - 143

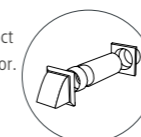



MODULAR FLIP DOWNDRAFT EXTRACTOR



PRODUCT CODE

DD522BK

DIMENSIONS

↳ w:520mm

PERFORMANCE

e Energy class B-C
For energy and performance see p.110 - 113

FINISH AVAILABLE

■ Black glass with stainless steel

FEATURES

- Illuminated touch controls
- For use with gas or electric hobs
- Perimetrical extraction for reduced noise and increased pressure resulting in improved motor performance
- Extracts from both sides, ideal for installation between modular hobs

- 4 Speeds
- Auto timer, switch-off after 10mins
- Aluminium grease filters
- Required ducting size 150mm
- Motor not included
- Recirculation kit available

MOTOR CHOICES

- Downdraft extractors will need to be purchased with a motor. For the full range please see p.108 - 109

OPTIONAL EXTRAS

- Recirculation kit [CAP72CF - only for use with motor DDMEXT28]
Visit caple.co.uk for full range

INSTALLATION

- Diagram [p.232]
- Venting Kits [p.143]
- The electric box must be located at least 650mm from the hob

Venting choices

Ensure you purchase the correct venting for your Cape extractor. For the full range please see p.142 - 143

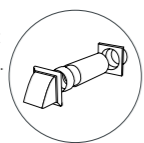

DOWNDRAFT EXTRACTORS



PRODUCT CODE

Stainless Steel DD606SS
Black Glass DD606BK

DIMENSIONS

↳ w:575mm

PERFORMANCE

e Energy class B-C
For energy and performance see p.110 - 113

FINISH AVAILABLE

■ Stainless steel
■ Black glass with stainless steel

FEATURES

- Electronic controls on stainless steel finish, touch control on black glass finish
- For use with gas or electric hobs
- Perimetrical extraction for reduced noise and increased pressure resulting in improved motor performance
- 4 Speeds [inc. Boost function]
- Auto timer, switch-off after 10mins
- Aluminium grease filters
- Required ducting size 150mm
- Motor not included
- Recirculation kit available

MOTOR CHOICES

- Downdraft extractors will need to be purchased with a motor. For the full range please see p.108 - 109.

OPTIONAL EXTRAS

- Recirculation kit [CAP27CF - only for use with motors DDMEXT11 and DDMEXT28]
Visit caple.co.uk for full range

INSTALLATION

- Diagram [p.232]
- Venting Kits [p.143]
- The electric box must be located at least 650mm from the hob

FLIP DOWNDRAFT



PRODUCT CODE

DD903BK

DIMENSIONS

↳ w:845mm

PERFORMANCE

e Energy class A-C
For energy and performance see p.110 - 113

FINISH AVAILABLE

■ Black glass with stainless steel

FEATURES

- Illuminated touch control
- Motor speed indicator light
- For use with gas or electric hobs
- Perimetrical extraction for reduced noise and increased pressure resulting in improved motor performance
- 4 Speeds
- Auto timer, switch-off after 10mins
- Aluminium grease filters
- Required ducting size 150mm
- Motor not included
- Recirculation kit available

MOTOR CHOICES

- Downdraft extractors will need to be purchased with a motor. This model can be used with DDMEXT21, DDMEXT28 and DDMEXT30. For the full range please see p.108 - 109.

OPTIONAL EXTRAS

- Recirculation kit [2 x CAP66CF - only for use with motor DDMEXT28]
Visit caple.co.uk for full range

INSTALLATION

- Diagram [p.232]
- Venting Kits [p.143]
- The electric box must be located at least 650mm from the hob



Ceiling Hoods

Style is nothing without functionality. Naturally, Caple's ceiling extractors come with both, as standard.

They're available in various sizes and engineered to achieve the very highest extraction rates. There's also a choice of motors, which can be positioned in a range of locations to reduce noise and free-up space.



Every Caple ceiling extractor uses our perimetric extraction system, which draws air in through narrow apertures around the full perimeter of the pan. It means higher air pressure, greater efficiency and less noise.

CREATING THE RIGHT ATMOSPHERE

You can also select just the right kind of lighting you want for your kitchen - from bright white to a soft, cosy, glow.

CONTROL AT YOUR FINGERTIPS

Our user-friendly remote control places power and lighting functions within easy reach. It also allows you to set the handy timer function, which automatically switches off the extractor after 10 minutes. When you leave your kitchen you know that any odours will be gone by the time you return.

CENTRE STAGE

We love the challenge of making functionality look stunning. Our hoods represent the epitome of contemporary design and technology.

Perfectly complementing any other Caple product, our ceiling hoods provide performance and styling like no other.

LED strip lighting, white glass finish and intelligent features ensure it has a place not only as a talking point in your kitchen, but an invaluable and practical addition.

MOTOR CHOICES

Some models have unique built-in motors, others will need to be purchased with a motor. To get the right power for you see our full range of motors on p.108 - 109.



CEILING HOOD WITH BUILT-IN MOTOR



IMAGE SHOWING RECESSED FITTING OPTION

PRODUCT CODE

CE1000

DIMENSIONS

↔ w:1000mm

PERFORMANCE

e Energy class B
Max. extraction 757m3/h
Max. noise level 61dB[A]
Fluid dynamic efficiency A
Grease absorption F

FINISH AVAILABLE

White glass with stainless steel

FEATURES

- Motor included
- Remote control included
- Perimetric extraction for reduced noise and increased pressure resulting in improved motor performance
- Can be fitted with motor exposed or recessed
- Suitable for recirculation of ducted installation
- 4 Speeds
- 2 x 15.5W LED strip lights [dimnable]
- Auto timer, switch-off after 10mins
- Aluminium grease filters
- Ducting spigot size 150mm 

OPTIONAL EXTRAS

- Washable carbon filter [CAP59CF]
- Visit caple.co.uk for full range

INSTALLATION

- Diagram [p.233]
- Venting Kits [p.143]

CEILING HOOD WITH BUILT-IN MOTOR



CE1122SS



CE1122WH

IMAGE SHOWING RECESSED FITTING OPTION

PRODUCT CODE

Stainless steel CE1122SS
White CE1122WH

DIMENSIONS

↔ w:1100mm

PERFORMANCE

e Energy class B
Max. extraction 753m3/h
Max. noise level 62dB[A]
Fluid dynamic efficiency A
Light efficiency E
Grease absorption F

FINISH AVAILABLE

Stainless Steel
 White Glass

FEATURES

- Motor included
- Remote control included
- Perimetric extraction for reduced noise and increased pressure resulting in improved motor performance
- 4 Speeds
- 2 x 18.5W LED strip lights with dimmer function
- Auto timer, switch-off after 10mins
- Aluminium grease filters
- Ducting spigot size 150mm 

OPTIONAL EXTRAS

- Recirculation kit [CAP64CF]
- Visit caple.co.uk for full range

INSTALLATION

- Diagram [p.233]
- Venting Kits [p.143]



CEILING HOOD

PRODUCT CODE

CE920WH

DIMENSIONS

↔ w:900mm

PERFORMANCE

e Energy class A++ - C
For energy and performance see p.110 - 113

FINISH AVAILABLE

☐ White glass with stainless steel

FEATURES

- Remote control included
- Perimetrical extraction for reduced noise and increased pressure resulting in improved motor performance
- 4 Speeds
- 3 x 2.5W LED lights [dimnable]
- Auto timer, switch-off after 10mins
- Aluminium grease filters
- Ducting spigot size 150mm 
- Ducted only installation
- Motor not included

MOTOR CHOICES

- Ceiling extractors will need to be purchased with a motor. For the full range please see p.108 - 109

INSTALLATION

- Diagram [p.233]
- Venting Kits [p.143]



CEILING HOOD



PRODUCT CODE

CE1101

DIMENSIONS

↔ w:1100mm

PERFORMANCE

e Energy class A+ - C
For energy and performance see p.110 - 113

FINISH AVAILABLE

☐ Stainless steel

FEATURES

- Remote control included
- Perimetrical extraction for reduced noise and increased pressure resulting in improved motor performance

- 4 Speeds [inc. Boost function]

- 4 x 16W dichroic lights with dimmer
- Auto timer, switch-off after 10mins
- Aluminium grease filters
- Required ducting size 150mm 
- Ducted only installation
- Motor not included

MOTOR CHOICES

- Ceiling extractors will need to be purchased with a motor. For the full range please see p.108 - 109

INSTALLATION

- Diagram [p.233]
- Venting Kits [p.143]

CEILING HOODS



CE902SS



CE902WH

PRODUCT CODE

Stainless Steel CE902SS
White CE902WH

DIMENSIONS

↔ w:900mm

PERFORMANCE

e Energy class A++ - B
For energy and performance see p.110 - 113

FINISH AVAILABLE

☐ Stainless steel
☐ White glass

FEATURES

- Remote control included
- Perimetrical extraction for reduced noise and increased pressure resulting in improved motor performance
- 4 Speeds [inc. Boost function]
- 2 x 6.5W LED light strips with dimmer function
- Aluminium grease filters
- Required ducting size 150mm 
- Ducted only installation
- Motor not included

MOTOR CHOICES

- Ceiling extractors will need to be purchased with a motor. For the full range please see p.108 - 109.

INSTALLATION

- Diagram [p.233]
- Venting Kits [p.143]

Venting choices

Ensure you purchase the correct venting for your Caple extractor. For the full range please see p.142 - 143

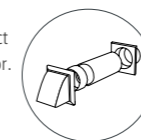

EXTRACTION MOTOR OPTIONS



PRODUCT CODE

DDMEXT11

PERFORMANCE

e For performance see p.110 - 113

FEATURES

- Motor for use with Caple downdraft extractors only [cannot be used with Caple ceiling hoods]
- For installation in cabinet fixing directly to the downdraft body
- Aluminium die-cast construction
- Required ducting size 150mm 

INSTALLATION

- Diagram [p.232]
- Venting Kits [p.143]

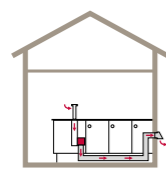

DDMEXT11 WITH DOWNDRAFT



PRODUCT CODE

DDMEXT21

PERFORMANCE

e For performance see p.110 - 113

FEATURES

- Motor for use with Caple downdraft or ceiling extractors
- For installation in ceiling cavity or floor space
- 7m long electrical connection cable [allowing motor installation up to 7m from the extractor]
- Aluminium die-cast construction
- Required ducting size 150mm 
- Rigid ducting must be used

INSTALLATION

- Diagram [p.232]
- Venting Kits [p.143]

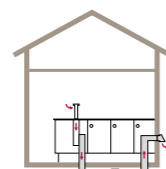

DDMEXT21 WITH DOWNDRAFT

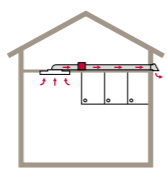

DDMEXT21 FOR CEILING



PRODUCT CODE

DDMEXT25

PERFORMANCE

e For performance see p.110 - 113

FEATURES

- Motor for use with Caple downdraft or ceiling extractors
- For installation in ceiling cavity or floor space
- 7m long electrical connection cable [allowing motor installation up to 7m from the extractor]
- Aluminium die-cast construction
- Required ducting size 150/200mm 
- Rigid ducting must be used

INSTALLATION

- Diagram [p.232]
- Venting Kits [p.143]

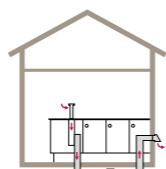

DDMEXT25 WITH DOWNDRAFT

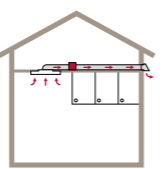

DDMEXT25 FOR CEILING

DUE TO THE POWER AND FITMENT OF OUR EXTERNAL MOTORS, RIGID DUCTING MUST BE USED.



PRODUCT CODE

DDMEXT28

PERFORMANCE

e For performance see p.110 - 113

FEATURES

- Motor for use with Caple downdraft extractors only [cannot be used with Caple ceiling hoods]
- For easy installation behind the plinth
- Aluminium die-cast construction
- Required ducting size 150mm 
- Rigid ducting must be used
- To be used in recirculation mode only [reirculation kit required, p. 142-143]

INSTALLATION

- Diagram [p.234]

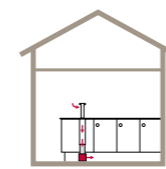

DDMEXT28 WITH DOWNDRAFT



PRODUCT CODE

DDMEXT30

PERFORMANCE

e For performance see p.110 - 113

FEATURES

- Motor for use with Caple downdraft or ceiling extractors
- For installation on outside wall
- 7m long electrical connection cable [allowing motor installation up to 7m from the extractor]
- Stainless steel die-cast construction
- Required ducting size 150mm 
- Rigid ducting must be used

INSTALLATION

- Diagram [p.234]
- Venting Kits [p.143]

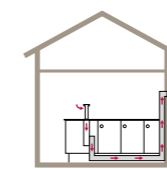

DDMEXT30 WITH DOWNDRAFT

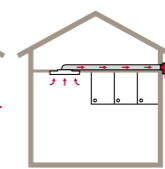

DDMEXT30 FOR CEILING



PRODUCT CODE

DDMEXT40

PERFORMANCE

e For performance see p.110 - 113

FEATURES

- Motor for use with Caple downdraft or ceiling extractors
- For installation on outside wall
- 7m long electrical connection cable [allowing motor installation up to 7m from the extractor]
- Stainless steel die-cast construction
- Required ducting size 150/200mm 
- Rigid ducting must be used

INSTALLATION

- Diagram [p.234]
- Venting Kits [p.143]

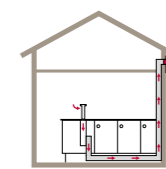

DDMEXT40 WITH DOWNDRAFT

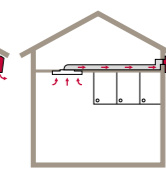

DDMEXT40 FOR CEILING

DUE TO THE POWER AND FITMENT OF OUR EXTERNAL MOTORS, RIGID DUCTING MUST BE USED.



MOTOR PERFORMANCE

You can choose from an extensive range of Caple motors to go with your extractor.

To help you decide which motor suits your needs this table shows the motor combinations and the specific associated performance levels.

If you require further information please contact us directly.



PRODUCT CODE	MOTOR CHOICE	DUCTING OUTLET SIZE [MM]
DOWNDRAFTS		
DD120BK	DDMEXT11	150
	DDMEXT21	150
	DDMEXT25	150
	DDMEXT25	200
	DDMEXT28	150
	DDMEXT30	150
	DDMEXT40	150
	DDMEXT40	200
DD911SS DD911BK DD911WH	DDMEXT11	150
	DDMEXT21	150
	DDMEXT25	150
	DDMEXT25	200
	DDMEXT28	150
	DDMEXT30	150
	DDMEXT40	150
	DDMEXT40	200
DD901BK	DDMEXT11	150
	DDMEXT21	150
	DDMEXT28	150
	DDMEXT30	150
DD606SS DD606BK	DDMEXT11	150
	DDMEXT21	150
	DDMEXT25	150
	DDMEXT25	200
	DDMEXT28	150
	DDMEXT30	150
	DDMEXT40	150
	DDMEXT40	200
DD522BK	DDMEXT21	150
	DDMEXT28	150
	DDMEXT30	150
	DDMEXT40	150
DD925CO	DDMEXT11	150
	DDMEXT21	150
	DDMEXT25	150
	DDMEXT28	150
	DDMEXT30	150

ENERGY CLASS	EXTRACTION RATE [m3/h]	FLUID DYNAMIC EFFICIENCY	LIGHT EFFICIENCY	GREASE ABSORPTION	NOISE LEVEL DB[A]	ANNUAL CONSUMPTION [kWh/yr]
e						
B	791	A	F	E	58	66
B	736	A	F	E	45	59
C	807	B	F	F	41	107
B	938	B	F	F	44	100
C	559	C	F	E	59	67
C	738	B	F	E	48	99
A	1310	A	F	F	55	121
A	1405	A	F	F	57	125
B	757	A	E	E	61	60
B	682	A	E	E	51	61
C	753	B	E	F	60	109
B	938	B	E	F	62	102
C	530	C	E	E	61	61
C	731	C	E	E	58	90
A	1240	A	E	F	58	116
A	1328	A	E	F	60	119
B	668	B	E	E	61	57
B	633	B	F	E	51	55
C	478	C	F	E	70	58
B	639	C	E	E	58	77
B	636	B	-	E	69	54
A	595	B	-	E	66	47
C	622	C	-	E	70	101
B	825	B	-	E	63	91
B	478	C	-	E	67	52
C	577	C	-	E	68	83
B	1110	A	-	E	64	130
B	1210	A	-	E	66	139
A	618	A	-	C	66	48
C	493	D	-	C	70	60
B	597	C	-	D	68	73
B	970	A	-	F	63	147
A	690	A	C	C	61	51
A	660	A	C	C	51	49
C	775	C	C	C	60	109
C	525	D	C	C	61	66
B	665	B	C	C	58	75

COOKING

II O

III

MOTOR PERFORMANCE



MOTOR PERFORMANCE



PRODUCT CODE	MOTOR CHOICE	DUCTING OUTLET SIZE [MM]
DD903BK	DDMEXT21	150
	DDMEXT28	150
	DDMEXT30	150
CEILING HOODS		
CE1101	DDMEXT21	150
	DDMEXT25	150
	DDMEXT25	200
	DDMEXT30	150
	DDMEXT40	150
	DDMEXT40	200
CE902SS & CE902WH	DDMEXT21	150
	DDMEXT25	150
	DDMEXT25	200
	DDMEXT30	150
	DDMEXT40	150
	DDMEXT40	200
CE920WH	DDMEXT21	150
	DDMEXT30	150
	DDMEXT40	150
	DDMEXT40	200

ENERGY CLASS	EXTRACTION RATE [m3/h]	FLUID DYNAMIC EFFICIENCY	LIGHT EFFICIENCY	GREASE ABSORPTION	NOISE LEVEL DB[A]	ANNUAL CONSUMPTION [kWh/yr]
e						
A	600	B	/	C	66	47
B	484	C	/	C	70	52
B	582	C	/	D	68	74
C	725	B	F	F	46	107
C	869	B	F	F	44	138
B	938	A	F	F	48	109
C	773	B	F	F	55	130
A	1464	A	F	F	69	139
A+	1543	A	F	F	71	126
B	670	B	B	F	44	63
B	900	B	B	F	42	97
B	965	A	B	F	46	99
B	790	B	B	F	47	88
A+	1490	A	B	F	67	102
A++	1575	A	B	F	69	89
B	665	A	A	F	58	55
C	693	C	A	F	61	84
A+	1464	A	A	F	69	98
A++	1543	A	A	F	71	85

COOKING

II2

II3

MOTOR PERFORMANCE



Island Hoods

High quality, highly efficient and intuitive our range of island hoods offer every kind of style to suit your kitchen.

COMPLETE CONTROL

Power and lighting adjustments at your fingertips with our user-friendly remote control. The handy timer function automatically switches off the extractor after 10 minutes, so you can leave your kitchen knowing any odours will have disappeared when you return - just some of the features from our fabulous island hood range.

CERAMICA

The Ceramica island hood with its incredibly eyecatching handmade ceramic body, features powerful extraction and exquisite attention to detail.



CR700



CR700WH



CR700SL

PRODUCT CODE

Copper	CR700
White	CR700WH
Silver	CR700SL

DIMENSIONS

↔ w:690mm

PERFORMANCE

e Max. Extraction 550m3/h
Max. Noise level 65dB[A]

FINISH AVAILABLE

	Copper
	White
	Silver

FEATURES

- Handmade ceramic body with stainless steel filter
- Remote control
- 4 Speeds
- 20W LED light
- Auto timer, switch-off after 10mins
- Stainless steel washable grease filter
- Recirculation only installation [supplied with washable recirculation kit]

OPTIONAL EXTRAS

- Replacement washable recirculation kit [CAP58CF]
- Visit caple.co.uk for full range

INSTALLATION

- Diagram [p.234]

Features

REMOTE CONTROL INCLUDED



CERAMICA ELLIAS

The Ellias island hood is a beautiful addition to the Ceramica family. The iconic handmade ceramic hood has adopted a distinctive contoured exterior with all the power and efficiency you would expect from Caple extraction.



CR750CO



CR750WH



CR750SL

PRODUCT CODE

Copper	CR750CO
White	CR750WH
Silver	CR750SL

DIMENSIONS

↔ w:690mm

PERFORMANCE

e Max. Extraction 550m3/h
Max. Noise level 68dB[A]

FINISH AVAILABLE

	Copper
	White
	Silver

FEATURES

- Handmade ceramic body with stainless steel filter
- Remote control
- 4 Speeds
- 20W LED light
- Auto timer, switch-off after 10mins
- Stainless steel washable grease filter
- Recirculation only installation [supplied with washable recirculation kit]

OPTIONAL EXTRAS

- Replacement washable recirculation kit [CAP58CF]
- Visit caple.co.uk for full range

INSTALLATION

- Diagram [p.234]

Features

REMOTE CONTROL INCLUDED



ZALTO

The Zalto offers iconic styling and exceptional performance. You can choose from a copper, silver or black finish. Whatever your preference, this hood offers stand-out looks whilst integrating perfectly into your kitchen.



ZAL48CO



ZAL48SL



ZAL48BK

PRODUCT CODE

Copper	ZAL48CO
Silver	ZAL48SL
Black	ZAL48BK

DIMENSIONS

↔ w:480mm

PERFORMANCE

e Max. extraction 550m³/h
Max. noise level 63dB[A]

FINISH AVAILABLE

- Copper
- Silver
- Black

FEATURES

- Remote control included
- Painted stainless steel finish
- 4 Speeds
- 40W Neon light
- Auto timer, switch-off after 10mins
- Aluminium washable grease filter
- Recirculation only installation [supplied with washable recirculation kit]

OPTIONAL EXTRAS

- Replacement washable recirculation kit [CAP74CF]
Visit cagle.co.uk for full range

INSTALLATION

- Diagram [p.234]

Features

REMOTE CONTROL INCLUDED



ISLAND HOODS



PLAZA



ORBIT

PRODUCT CODE

Pi402	Plaza
Oi363	Orbit

DIMENSIONS

↔ w:400mm	Pi402
↔ w:362mm	Oi362

PERFORMANCE

e Energy class A
Fluid dynamic efficiency A
Light efficiency A
Grease absorption D
Annual Consumption [Pi402] 53kWh/yr
[Oi363] 44kWh/yr
Max. extraction 730m³/h
Max. noise level 64dB[A]

FINISH AVAILABLE

Stainless Steel

Features

REMOTE CONTROL INCLUDED



FEATURES

- Remote control included
- 4 Speeds [inc. Boost setting]
- 1 x 4W high intensity LED light
- Auto timer, switch-off after 10mins
- Aluminium grease filter
- Required ducting size 150mm
- Recirculation kit available

PI402 OPTIONAL EXTRAS

- Recirculation kit [CAP39CF]
Visit cagle.co.uk for full range

OI362 OPTIONAL EXTRAS

- Recirculation kit [CAP38CF]
Visit cagle.co.uk for full range

INSTALLATION

- Diagram [p.234]
- Venting Kits [p.143]

ISLAND HOOD



PRODUCT CODE

BXi911

DIMENSIONS

↔ w:900mm

PERFORMANCE

e Energy class D
Fluid dynamic efficiency D
Light efficiency D
Grease absorption D
Annual Consumption 96kWh/yr
Max. extraction 605m³/h
Max. noise level 69dB[A]

FINISH AVAILABLE

Stainless steel

FEATURES

- Touch controls
- 3 Speeds
- 4 x 1.5W high intensity LED lights
- Aluminium grease filters
- Required ducting size 150mm
- Supplied with 2m length of semi-rigid ducting
- Recirculation kit available

OPTIONAL EXTRAS

- Recirculation kit [CAP61CF]
Visit cagle.co.uk for full range

INSTALLATION

- Diagram [p.234]
- Venting Kits [p.143]

Venting choices

Ensure you purchase the correct venting for your Cagle extractor. For the full range please see p.142 - 143

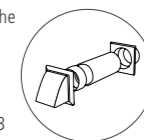



ISLAND HOOD

PRODUCT CODE

Zi922

DIMENSIONS

↔ w:900mm

PERFORMANCE

e Energy class B
 Fluid dynamic efficiency B
 Light efficiency A
 Grease absorption D
 Annual Consumption
 54kWh/yr
 Max. extraction 581m³/h
 Max. noise level 66dB[A]

FINISH AVAILABLE

■ Stainless steel with a black glass front panel

FEATURES

- Illuminated LED touch controls front and back
- 3 Speeds
- Large LED light panel
- Aluminium grease filters
- Required ducting size 150mm
- Recirculation kit available

OPTIONAL EXTRAS

- Recirculation kit [CAP61CF]
 Visit caple.co.uk for full range

INSTALLATION

- Diagram [p.235]
- Venting Kits [p.143]



ISLAND HOOD



PRODUCT CODE

CGi921

DIMENSIONS

↔ w:900mm
 h:920-1240mm

PERFORMANCE

e Energy class A
 Fluid dynamic efficiency A
 Light efficiency C
 Grease absorption D
 Annual Consumption
 42kWh/yr
 Max. extraction 617m³/h
 Max. noise level 68dB[A]

FINISH AVAILABLE

■ Stainless steel with curved clear glass

FEATURES

- Touch controls
- 3 Speeds
- 4 x 1.5W high intensity LED lights
- Aluminium grease filters
- Required ducting size 150mm
- Supplied with 2m length of semi-rigid ducting
- Recirculation kit available

OPTIONAL EXTRAS

- Recirculation kit [CAP61CF]
 Visit caple.co.uk for full range

INSTALLATION

- Diagram [p.235]
- Venting Kits [p.143]

REDUCED CEILING HEIGHT ISLAND HOOD

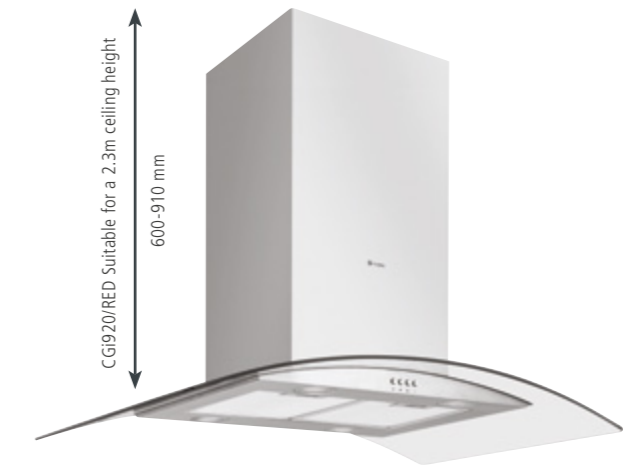

PRODUCT CODE

CGi920/RED
 [Reduced ceiling height]

DIMENSIONS

↔ w:900mm
 h:600-910mm

PERFORMANCE

e Energy class D
 Fluid dynamic efficiency D
 Light efficiency C
 Grease absorption D
 Annual Consumption
 96kWh/yr
 Max. extraction 608m³/h
 Max. noise level 69dB[A]

FINISH AVAILABLE

■ Stainless steel with curved clear glass

FEATURES

- Electronic controls
- 3 Speeds
- 4 x 1.5W high intensity LED lights
- Aluminium grease filters
- Required ducting size 150mm
- Supplied with 2m length of semi-rigid ducting
- Recirculation kit available

OPTIONAL EXTRAS

- Recirculation kit [CAP61CF]
 Visit caple.co.uk for full range

INSTALLATION

- Diagram [p.235]
- Venting Kits [p.143]

Venting choices

Ensure you purchase the correct venting for your Caple extractor. For the full range please see p.142 - 143

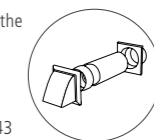



Wall Chimney Hoods

Our practical and stylish chimney hoods are sure to make a statement. Multi-functional and great to look at extraction will be a joy when you cook.

NOVA

Discreet, slimline and powerful, the Nova neatly mounts on the wall keeping a low profile until it is brought to life by the illuminated touch controls. Finished with a delicate stainless steel trim, this hood exceeds every expectation.



PRODUCT CODE

NOV800

DIMENSIONS

↔ w:800mm

PERFORMANCE

e Energy class A
 Fluid Dynamic Efficiency A
 Light Efficiency A
 Grease Absorption C
 Annual Consumption 43kWh/yr
 Max. extraction 615m³/h
 Max. noise level 60dB[A]

FINISH AVAILABLE

■ Black glass

FEATURES

- 4 Speeds [inc. Boost function]
- Touch control
- Auto timer, switch-off after 10mins
- 10.5W white LED strip light
- Aluminium grease filters
- Ducting spigot size 150mm 
- Flat channel ducting required [p.142 - 143]
- Recirculation kit available

OPTIONAL EXTRAS

- Recirculation kit [CAP77CF]
 Visit caple.co.uk for full range

INSTALLATION

- Diagram [p.235]
- Venting Kits [p.143]



Venting choices

Ensure you purchase the correct venting for your Caple extractor. For the full range please see p.142 - 143

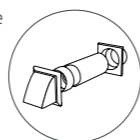

TAURI

The clean lines and striking aesthetics of Tauri sets this hood apart from the rest. Featuring a sleek, glass fronted touch control panel and exposed stainless steel filters, it's sure to make a design statement in any kitchen.



PRODUCT CODE

TAU760

DIMENSIONS

↔ w:800mm

PERFORMANCE

e Energy class A+
 Fluid Dynamic Efficiency A
 Light Efficiency A
 Grease Absorption C
 Annual Consumption 46kWh/yr
 Max. extraction 777m³/h
 Max. noise level 61dB[A]

FINISH AVAILABLE

■ Black glass with glass

FEATURES

- 4 Speeds [inc. Boost function]
- Touch control
- Auto timer, switch-off after 10mins
- 10.5W white LED strip light
- Polished stainless steel grease filters
- Ducting spigot size 150mm 
- Recirculation kit available

OPTIONAL EXTRAS

- Recirculation kit [CAP79CF]
 Visit caple.co.uk for full range

INSTALLATION

- Diagram [p.235]
- Venting Kits [p.143]



Venting choices

Ensure you purchase the correct venting for your Caple extractor. For the full range please see p.142 - 143

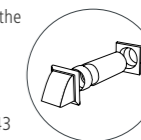

MOTUS TOUCH

Minimal, sleek styling and advanced engineering combine effortlessly to make an exceptional extractor. It slides smoothly into action, operated via subtle, elegant electronic touch controls.

PRODUCT CODE

MOT912

DIMENSIONS

↔ w:900mm

PERFORMANCE

e Energy class A+
 Fluid Dynamic Efficiency A
 Light Efficiency B
 Grease Absorption D
 Annual Consumption
 46kWh/yr
 Max. extraction 757m³/h
 Max. noise level 62dB[A]

FINISH AVAILABLE

■ Black glass with stainless steel

FEATURES

- Supplied with optional stainless steel flue
- Full touch controls with electronic display
- Mechanical automatic opening [dependent on speed setting]
- Perimetrical extraction for reduced noise and increased pressure resulting in improved motor performance
- 4 Speeds [inc. Boost setting]
- 10W LED strip light
- Auto timer, switch-off after 10mins
- Aluminium washable grease filters
- Required ducting size 150mm 
- Recirculation kit available

OPTIONAL EXTRAS

- Recirculation kit [CAP52CF]
 Visit caple.co.uk for full range

INSTALLATION

- Diagram [p.236]
- Venting Kits [p.143]



ELEGANT EFFICIENCY

The Motus hood glides into action with touch control operation and an electric blue display.



STAGE 1

The whisper quiet perimetrical extraction system removes even the subtlest odours.



STAGE 2

The black glass front rises further to reveal the aluminium filters as the extraction level increases.



STAGE 3

It glides effortlessly into position to remove even those hard to shift cooking odours.



STAGE 4

Maximum extraction when you need it most. Still operating below an impressive 62dB[A].

OMNIS

The ultra-modern, sleek black glass and slanted edges is ideal if you want to create a minimal and stylish look.



OM900

OM600

PRODUCT CODE

OM900

OM600

DIMENSIONS

↔ w:900mm OM900
 ↔ w:600mm OM600

PERFORMANCE

e Energy class C
 Fluid Dynamic Efficiency D
 Light Efficiency B
 Grease Absorption
 C [OM600]
 B [OM900]
 Annual Consumption
 51kWh/yr
 Max. extraction 456m³/h
 Max. noise level 62dB[A]

FINISH AVAILABLE

■ Black glass

FEATURES

- Illuminated LED touch controls
- 3 Speeds
- 2 x 1.5W LED lights
- Aluminium grease filters
- Ducting spigot size 150mm 
- Recirculation kit available

OPTIONAL EXTRAS

- Recirculation kit [CAP61CF]
 Visit caple.co.uk for full range

INSTALLATION

- Diagram [p.236]
- Venting Kits [p.143]

Venting choices

Ensure you purchase the correct venting for your Caple extractor. For the full range please see p.142 - 143

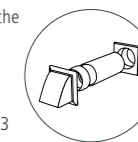

SPIRIT

Choose from smooth black glass or go for stainless steel with smoked glass. What's more, this hood can also work in recirculation mode.



SP912SS



SP612SS



SP912BK



SP612BK

PRODUCT CODE

Stainless Steel	SP912SS
Black Glass	SP912BK
Stainless Steel	SP612SS
Black Glass	SP612BK

DIMENSIONS

↔	w:900mm	SP912SS
	w:900mm	SP912BK
	w:600mm	SP612SS
	w:600mm	SP612BK

PERFORMANCE

e	Energy class A
	Fluid Dynamic Efficiency A
	Light Efficiency C
	Grease Absorption D
	Annual Consumption 42kWh/yr
	Max. extraction 612m3/h
	Max. noise level 66dB[A]

FINISH AVAILABLE

- Stainless steel with glass panels
- Black with black glass panels

FEATURES

- Touch controls
- 3 Speeds
- 2 x 1.5W high intensity LED lights
- Aluminium grease filters
- Supplied with 2m length of semi-rigid ducting
- Required ducting size 150mm
- Recirculation kit available

OPTIONAL EXTRAS

- Recirculation kit [CAP61CF]
Visit caple.co.uk for full range

INSTALLATION

- Diagram [p.236]
- Venting Kits [p.143]

ZODIAC

The light box illuminates the hob below so you can see exactly what your cooking. Combine this with impressive performance and finish it off with simple touch controls, Zodiac hoods are the perfect choice.



ZC922



ZC622

PRODUCT CODE

ZC922
ZC622

DIMENSIONS

↔	w:900mm	ZC922
	w:600mm	ZC622

ZC922 PERFORMANCE

e	Energy class B
	Fluid Dynamic Efficiency A
	Light Efficiency A
	Grease Absorption D
	Annual Consumption 45kWh/yr
	Max. extraction 587m3/h
	Max. noise level 66dB[A]

ZC622 PERFORMANCE

e	Energy class B
	Fluid Dynamic Efficiency B
	Light Efficiency A
	Grease Absorption D
	Annual Consumption 54kWh/yr
	Max. extraction 570m3/h
	Max. noise level 66dB[A]

FINISH AVAILABLE

- Stainless steel with black glass panel

FEATURES

- Illuminated LED touch control
- 3 Speeds
- Large LED light panel
- Aluminium grease filters
- Required ducting size 150mm
- Recirculation kit available

OPTIONAL EXTRAS

- Recirculation kit [CAP61CF]
Visit caple.co.uk for full range

INSTALLATION

- Diagram [p.236]
- Venting Kits [p.143]

Venting choices

Ensure you purchase the correct venting for your Caple extractor. For the full range please see p.142 - 143

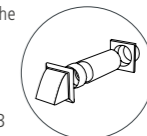

ZELLA

The unique black or gunmetal aluminium wings frame a beautifully smooth sheet of sleek black glass. The minimal styling and touch control are perfect for creating an ultra-modern look.

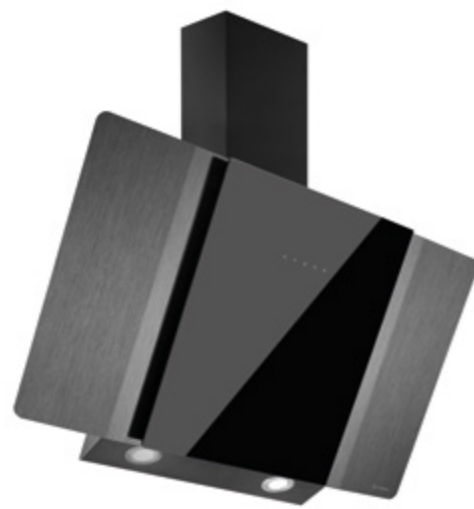

ZEL900GM



ZEL900

PRODUCT CODE

ZEL900GM
ZEL900



DIMENSIONS

↔ w:900mm

PERFORMANCE

e Energy class A
Fluid Dynamic Efficiency A
Light Efficiency C
Grease Absorption D
Annual Consumption
43kWh/yr
Max. extraction 612m³/h
Max. noise level 66dB[A]

FINISH AVAILABLE

 Gunmetal and black glass
 Black glass and aluminium

FEATURES

- Illuminated LED touch control
- 3 Speeds
- 2 x 1.5W LED lights
- Aluminium grease filters
- Required ducting size 150mm 
- Recirculation kit available

OPTIONAL EXTRAS

- Recirculation kit [CAP61CF]
Visit caple.co.uk for full range

INSTALLATION

- Diagram [p.236]
- Venting Kits [p.143]

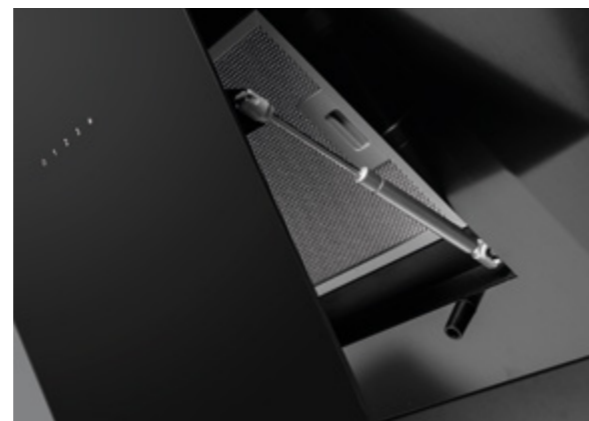

Venting choices

Ensure you purchase the correct venting for your Caple extractor.
For the full range please see p.142 - 143

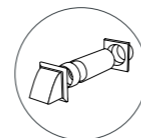



Classic Hoods

From bold statement pieces to discreet integrated models. Whatever you're looking for, we can help.

You'll find a near-endless choice of styles and functionality in the Classic range. Whichever you opt for, you can guarantee it will perform to the highest standards and keep your kitchen free from odours and grease, while powerful halogen or LED lights illuminate the cooking zone below.



WALL CHIMNEY HOODS



FGC920

FGC720

FGC620

PRODUCT CODE

FGC920
FGC720
FGC620

DIMENSIONS

↔	w:895mm	FGC920
	w:695mm	FGC720
	w:595mm	FGC620

PERFORMANCE

e Energy class D
Fluid Dynamic Efficiency D
Light Efficiency B
Grease Absorption C
Annual Consumption
60kWh/yr
Max. extraction 580m³/h
Max. noise level 68dB[A]

FINISH AVAILABLE

Stainless steel with flat clear glass

FEATURES

- Push button controls
- 3 Speeds
- 2 x 1.5W high intensity LED lights
- Aluminium grease filter
- Required ducting size 150mm
- Supplied with 2m length of semi-rigid ducting
- Recirculation kit available

OPTIONAL EXTRAS

- Recirculation kit [CAP61CF]
Visit caple.co.uk for full range

INSTALLATION

- Diagram [p.237]
- Venting Kits [p.143]

Features

FUNCTION & POWER

This model has a powerful maximum extraction rate of 580m³/h, perfect if you're looking for style, functionality and raw power.



WALL CHIMNEY HOODS



CGC911SS



CGC711SS



CGC611SS



CGC911BK



CGC711BK



CGC611BK

PRODUCT CODE

Stainless Steel	CGC911SS
Black	CGC911BK
Stainless Steel	CGC711SS
Black	CGC711BK
Stainless Steel	CGC611SS
Black	CGC611BK

DIMENSIONS

↔	w:895mm	CGC911SS
	w:895mm	CGC911BK
	w:695mm	CGC711SS
	w:695mm	CGC711BK
	w:595mm	CGC611SS
	w:595mm	CGC611BK

PERFORMANCE

e Energy class C
Fluid Dynamic Efficiency D
Light Efficiency A
Grease Absorption C
Annual Consumption
52kWh/yr
Max. extraction 456m³/h
Max. noise level 56dB[A]

FINISH AVAILABLE

- Stainless steel with curved clear glass
- Black with curved clear glass

FEATURES

- Push button controls
- 3 Speeds
- 2 x 1.5W high intensity LED lights
- Aluminium grease filters
- Required ducting size 150mm
- Supplied with 2m length of semi-rigid ducting
- Recirculation kit available

OPTIONAL EXTRAS

- Recirculation kit [CAP75CF]
Visit caple.co.uk for full range

INSTALLATION

- Diagram [p.237]
- Venting Kits [p.143]

Venting choices

Ensure you purchase the correct venting for your Caple extractor. For the full range please see p.142 - 143

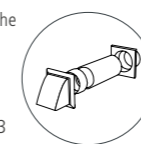

Features

SPLASHBACK

This unique splashback has been designed to fit perfectly with the curved canopy of the Caple CGC hoods and is available in black, pewter or stainless steel – see p144 - 147





WALL CHIMNEY HOODS

PRODUCT CODE

BXC911

BXC611

DIMENSIONS

↔ w:900mm BXC911
 ↕ w:600mm BXC611

PERFORMANCE

BXC911

e Energy class C
 Fluid Dynamic Efficiency D
 Light Efficiency C
 Grease Absorption D
 Annual Consumption
 86kWh/yr
 Max. extraction 571m³/h
 Max. noise level 76dB[A]

BXC611

e Energy class C
 Fluid Dynamic Efficiency D
 Light Efficiency B
 Grease Absorption B
 Annual Consumption
 50kWh/yr
 Max. extraction 456m³/h
 Max. noise level 56dB[A]

FINISH AVAILABLE

■ Stainless steel

FEATURES

- Touch controls
- 3 Speeds
- 2 x 1.5W high intensity LED lights
- Aluminium grease filters
- Required ducting size 150mm
- Recirculation kit available

OPTIONAL EXTRAS

- Recirculation kit [CAP61CF]
 Visit caple.co.uk for full range

INSTALLATION

- Diagram [p.237]
- Venting Kits [p.143]



BXC911



BXC611

Features

FUNCTION & POWER

The seamlessly crafted stainless steel features easy-to-use touch controls to create a stylish focal point in your kitchen.



WALL CHIMNEY HOODS

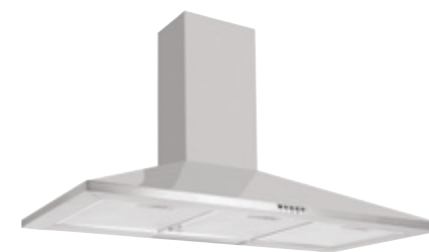

CCH100



CCH901SS



CCH901BK



CCH700



CCH601SS



CCH601BK

PRODUCT CODE

Stainless Steel	CCH100
Stainless Steel	CCH901SS
Black	CCH901BK
Stainless Steel	CCH700
Stainless Steel	CCH601SS
Black	CCH601BK

DIMENSIONS

↔ w:1000mm	CCH100
↔ w:900mm	CCH901SS
w:900mm	CCH901BK
w:700mm	CCH700
w:600mm	CCH601SS
w:600mm	CCH601BK

PERFORMANCE

CCH601 & CCH901

e Energy class C
 Fluid Dynamic Efficiency E
 Light Efficiency A
 Grease Absorption C
 Annual Consumption
 36kWh/yr [CCH601]
 Annual Consumption
 37kWh/yr [CCH901]
 Max. extraction 305m³/h
 Max. noise level 62dB[A]

CCH100 & CCH700

e Energy class D
 Fluid Dynamic Efficiency E
 Light Efficiency G
 Grease Absorption D [CCH100]
 Grease Absorption C [CCH700]
 Annual Consumption 74kWh/yr
 Max. extraction 299m³/h
 Max. noise level 63dB[A]

FINISH AVAILABLE

■ Stainless steel
 ■ Black

FEATURES

- Push button controls
- 3 Speeds
- 2 x 28W eco halogen lights [CCH100 & CCH700]
- 1 x 2W LED light [CCH601 & CCH901]
- Aluminium grease filters
- Required ducting size 150mm
- Supplied with 2m length of semi-rigid ducting
- Recirculation kit available

OPTIONAL EXTRAS

- Recirculation kit [CAP60CF]
 Visit caple.co.uk for full range

INSTALLATION

- Diagram [p.238]
- Venting Kits [p.143]

Features

FUNCTION & POWER

Simple in design, efficient in performance with a choice of two finishes to suit your kitchen.



VENTING CHOICES

Ensure you purchase the correct venting for your Caple extractor. For the full range please see p.142 - 143

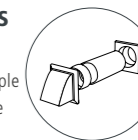

INTEGRATED HOOD



PRODUCT CODE

INCH

DIMENSIONS

↔ w:600mm

PERFORMANCE

e Energy class C
 Fluid Dynamic Efficiency E
 Light Efficiency B
 Grease Absorption D
 Annual Consumption
 37kWh/yr
 Max. extraction 285m³/h
 Max. noise level 64dB[A]

FINISH AVAILABLE

■ Silver grey

FEATURES

- Slider control
- 3 Speeds
- 2 x 2W LED lights
- Aluminium grease filters
- Ducting spigot size 150mm
- Recirculation kit available

OPTIONAL EXTRAS

- Recirculation kit [CAP73CF]
 Visit caple.co.uk for full range

INSTALLATION

- Diagram [p.238]
- Venting Kits [p.143]

STORM BUILT-UNDER HOODS



ST853



ST523

PRODUCT CODE

ST853

ST523

DIMENSIONS

↔ w:850mm ST853
 ↔ w:520mm ST523

PERFORMANCE

ST853

e Energy class A
 Fluid Dynamic Efficiency A
 Light Efficiency B
 Grease Absorption A
 Annual Consumption
 49kWh/yr
 Max. extraction 745m³/h
 Max. noise level 63dB[A]

ST523

e Energy class A
 Fluid Dynamic Efficiency
 Light Efficiency A
 Grease Absorption A
 Annual Consumption
 47kWh/yr
 Max. extraction 680m³/h
 Max. noise level 63dB[A]

FINISH AVAILABLE

■ Stainless steel

FEATURES

- Electronic controls
- 4 Speeds [inc. Boost]
- Auto timer
- 6W LED strip light
- Stainless steel grease filters
- Required ducting size 150mm
- Recirculation kit available

ST853 OPTIONAL EXTRAS

- Recirculation kit [CAP65CF - 2 required]
 Visit caple.co.uk for full range

ST523 OPTIONAL EXTRAS

- Recirculation kit [CAP54CF - 2 required]
 Visit caple.co.uk for full range

INSTALLATION

- Diagram [p.239]
- Venting Kits [p.143]

TOUCH CONTROL BUILT-UNDER HOODS

PRODUCT CODE

TBU850

TBU520

DIMENSIONS

↔ w:850mm TBU850
 ↔ w:520mm TBU520

PERFORMANCE

TBU850

e Energy class A+
 Fluid Dynamic Efficiency A
 Light Efficiency B
 Grease Absorption A
 Annual Consumption
 46kWh/yr
 Max. extraction 772m³/h
 Max. noise level 63dB[A]

TBU520

e Energy class A
 Fluid Dynamic Efficiency A
 Light Efficiency A
 Grease Absorption A
 Annual Consumption
 47kWh/yr
 Max. extraction 680m³/h
 Max. noise level 63dB[A]

FINISH AVAILABLE

■ Stainless steel

FEATURES

- Fold away glass panel with illuminated touch control
- 4 Speeds [inc. Boost function]
- Auto timer, switch-off after 10mins
- 10.5W LED strip light [TBU850]
- 6.5W white LED strip light [TBU520]
- Aluminium grease filter
- Ducting spigot size 150mm
- Recirculation kit available

OPTIONAL EXTRAS

- TBU850 Recirculation kit [CAP42CF - 2 required]
- TBU520 Recirculation kit [CAP78CF]
 Visit caple.co.uk for full range

INSTALLATION

- Diagram [p.238-239]
- Venting Kits [p.143]



TBU850



TBU520



Venting choices

Ensure you purchase the correct venting for your Caple extractor. For the full range please see p.142 - 143

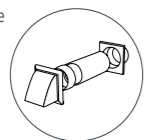

BUILT-UNDER HOOD



PRODUCT CODE

BU521

DIMENSIONS

↔ w:520mm

PERFORMANCE

e Energy class B
 Fluid Dynamic Efficiency B
 Light Efficiency A
 Grease Absorption B
 Annual Consumption
 58kWh/yr
 Max. extraction 604m³/h
 Max. noise level 70dB[A]

FINISH AVAILABLE

■ Stainless steel

FEATURES

- Push button controls
- 3 Speeds
- 2 x 2.1w high intensity LED light
- Aluminium grease filter
- Required ducting size 150mm
- Recirculation kit available

OPTIONAL EXTRAS

- Recirculation kit [CAP66CF]
 Visit caple.co.uk for full range

INSTALLATION

- Diagram [p.239]
- Venting Kits [p.143]

BUILT-UNDER TELESCOPIC HOOD



PRODUCT CODE

TSCH601

DIMENSIONS

↔ w:600mm

PERFORMANCE

e Energy class C
 Fluid Dynamic Efficiency E
 Light Efficiency A
 Grease Absorption D
 Annual Consumption
 32kWh/yr
 Max. extraction
 291.3m³/h
 Max. noise level 65dB[A]

FINISH AVAILABLE

■ Stainless steel fascia with silver grey body

FEATURES

- Dual switch controls
- 2 Speeds
- 1 x 2W LED light
- Aluminium grease filter
- Required ducting size 150mm
- Recirculation kit available

OPTIONAL EXTRAS

- Recirculation kit [CAP60CF]
 Visit caple.co.uk for full range

INSTALLATION

- Diagram [p.239]
- Venting Kits [p.143]



BUILT-UNDER HOOD



PRODUCT CODE

BUCH

DIMENSIONS

↔ w:520mm

PERFORMANCE

e Energy class C
 Fluid Dynamic Efficiency E
 Light Efficiency B
 Grease Absorption D
 Annual Consumption
 37kWh/yr
 Max. extraction 286m³/h
 Max. noise level 62dB[A]

FINISH AVAILABLE

■ Stainless steel

FEATURES

- Slider controls
- 3 Speeds
- 2 x 2W LED lights
- Aluminium grease filters
- Required ducting size 150mm
- Recirculation kit available

OPTIONAL EXTRAS

- Recirculation kit [CAP73CF]
 Visit caple.co.uk for full range

INSTALLATION

- Diagram [p.239]
- Venting Kits [p.143]

CONVENTIONAL HOOD



PRODUCT CODE

FSCHS8

DIMENSIONS

↔ w:600mm

PERFORMANCE

e Energy class C
 Fluid Dynamic Efficiency E
 Light Efficiency A
 Grease Absorption D
 Annual Consumption
 30kWh/yr
 Max. extraction 194m³/h
 Max. noise level 60dB[A]

FINISH AVAILABLE

■ Stainless steel

FEATURES

- Push button controls
- 3 Speeds
- 1 x 2W LED light
- Aluminium grease filters
- Required ducting size 120mm
- Recirculation kit available

OPTIONAL EXTRAS

- Recirculation kit [CAP80CF]
 Visit caple.co.uk for full range

INSTALLATION

- Diagram [p.239]
- Venting Kits [p.143]

Venting choices

Ensure you purchase the correct venting for your Caple extractor. For the full range please see p.142 - 143

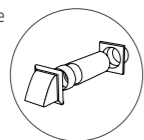



HIGH EFFICIENCY VENTING

VENTING

To ensure you get the most out of your extraction we have the perfect venting solution to suit your needs.



125MM ELBOW BEND
[CODE 550GL]

- Suitable for 125mm flat channel ducting [204 x 60mm] Can be used with C227W and 515W

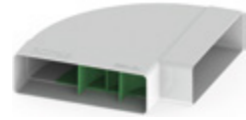

150MM ELBOW BEND
[CODE C950GL]

- Suitable for 150mm flat channel ducting [220 x 90mm] Can be used with C2653WGL, C2655WGL and 915W



150MM VENTING KIT
[CODE C2653WGL]

- For hoods with extraction over 500m³/h
- 3 metre venting kit



150MM VENTING KIT
[CODE C2655WGL]

- Suitable for use with downdraft hoods
- 3 metre rigid venting kit



Due to the profile of a duct bend, air travelling through it can become turbulent causing increased resistance and noise. As a consequence the cooker hood will need to work harder in order to meet the required airflow rates, therefore consuming more energy. This high efficiency 90° bend has been designed to allow a uniform flow of air through the section of ducting, reducing the resistance by up to 60% and lowering the air speed. All of which results in a quieter and more efficient system.

- Smoothly channels air through the duct bend in a uniform flow
- Reduced duct resistance by up to 60% to lower the systems pressure drop and overall energy usage
- Reduced air speed through the bend to reduce noise
- Performance has been tested by the Building Research Establishment [BRE]

The diagram illustrates the improvement of air flow when using 550GL or C950GL ducting

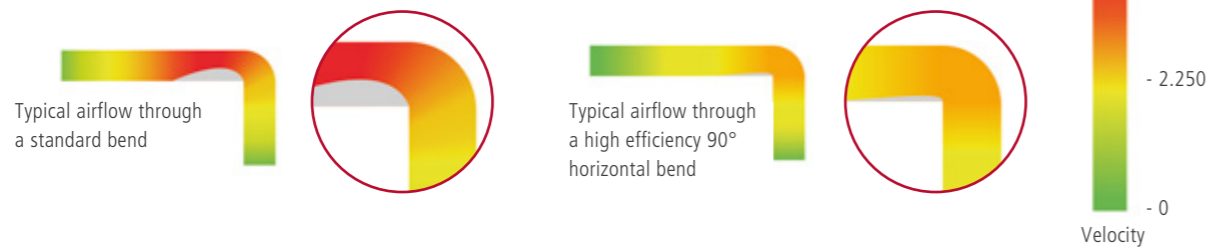

100MM VENTING KIT
[CODE C202W]

1 Metre flexible venting kit



100MM VENTING KIT
[CODE 212W]

2 Metre venting kit



125MM VENTING KIT
[CODE 202-5W]

1 Metre flexible venting kit



125MM VENTING KIT
[CODE C227W]

3 Metre venting kit



150MM VENTING KIT
[CODE C202-6W]

1 Metre flexible venting kit

CHOOSING THE RIGHT VENTING

To ensure you have the correct venting for your chosen hood, please refer to the hood specification where the required diameter kit is listed.

EXTERNAL MOTORS

Due to the power and fitment of Caple external motors [DDMEXT11, DDMEXT21, DDMEXT25, DDMEXT28, DDMEXT30 and DDMEXT40, see p.108 - 109] you must use rigid ducting.

COOLING VENTING

When installing integrated refrigeration it is important to use the correct venting.



VENTING GRILLE
[CODE CVGS]

Worktop aluminium vent



Splashbacks

The perfect finishing touch.



TOUGHENED GLASS SPLASHBACK



PRODUCT CODE

TSB1000**
 [Available in black and pewter only]
 TSB900**
 TSB600**

DIMENSIONS

h:750mm	d:5mm
TSB1000	w:1000mm
TSB900	w:900mm
TSB600	w:600mm

FEATURES

- 10 Colours available
- Will not mark with fingerprints
- Adhesive backed for quick and easy DIY installation [no unsightly fixing screws]
- Toughened glass
- Conforms to BS EN12150:1 British Safety Standards
- Hygienic
- Opaque colour finish
- Can be applied to all flat non-porous, clean surfaces

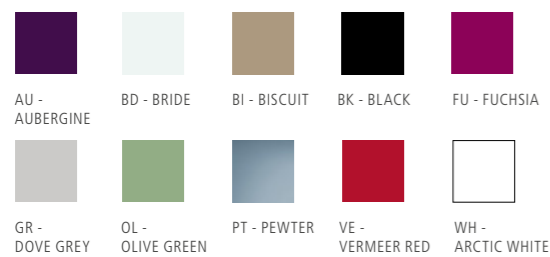

For chosen colour option, replace '' with colour code – see swatches above.

CURVED TOUGHENED GLASS SPLASHBACK



PRODUCT CODE

TSBCURVE900**
 TSBCURVE700**
 TSBCURVE600**

DIMENSIONS

h:750mm	d:5mm
TSBCURVE900**	w:895mm [Fits CGC911 pg.135]
TSBCURVE700**	w:695mm [Fits CGC711 pg.135]
TSBCURVE600**	w:595mm [Fits CGC611 pg.135]

FEATURES

- 2 Colours available
- Fits Caple CGC hoods [p.135]
- Will not mark with fingerprints
- Adhesive backed for quick and easy DIY installation [no unsightly fixing screws]
- Toughened glass
- Conforms to BS EN12150:1 British Safety Standards
- Hygienic
- Opaque colour finish
- Can be applied to all flat non-porous, clean surfaces

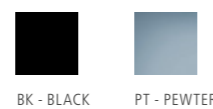

For chosen colour option, replace '' with colour code – see swatches above.

Features

SAFE & EASY TO INSTALL

All Caple glass splashbacks are adhesive-backed. This stops them shattering and allows fitting to any clean, non-porous surface. All our glass products meet British Safety Standards and are made from toughened glass.



STAINLESS STEEL SPLASHBACK



PRODUCT CODE

CSB1006
 CSB906
 CSB706
 CSB606

DIMENSIONS

h:750mm	d:10.5mm
CSB1006	w:1000mm
CSB906	w:900mm
CSB706	w:700mm
CSB606	w:600mm



STAINLESS STEEL

CURVED STAINLESS STEEL SPLASHBACK



PRODUCT CODE

CSBCURVE905
 CSBCURVE705
 CSBCURVE605

DIMENSIONS

h:750mm	d:10.5mm
CSBCURVE905	w:900mm [Fits CGC911 pg.135]
CSBCURVE705	w:700mm [Fits CGC711 pg.135]
CSBCURVE605	w:600mm [Fits CGC611 pg.135]



STAINLESS STEEL



COOLING

PROFESSIONAL REFRIGERATION	154
FREESTANDING REFRIGERATION	156
INTEGRATED REFRIGERATION	163
WINE CABINETS	174

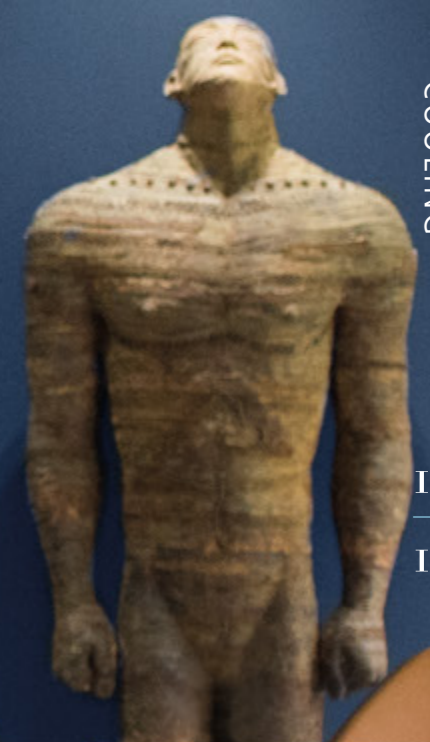

COOLING

148
149





Refrigeration

Chill it, freeze it, love it.

Whether you want a discreet space-saving
under-counter fridge or something more spacious,
you'll find it right here.



Whatever you want, that's cool.

We've one for every kind of kitchen, big or small.
Different colours, different finishes, different sizes
and plenty of functionality.

PROFESSIONAL

The CAFF60 has a massive 820L capacity in six compartments, as well as three separate temperature zones - one freezer and two fridge zones. Each of which can be set to a different temperature. It can be built-in or used as a freestanding appliance.



FRENCH DOOR

This large, freestanding fridge freezer has two doors on the top for the fridge and drawers underneath for the freezer, great for storing large items.



SIDE-BY-SIDE

Big on looks and big on capacity. Available in black or stainless steel some side-by-side fridge freezers can also be plumbed in for a constant supply of cold filtered water and ice.



70/30 FREESTANDING

This is the perfect option when space is key. This stacked refrigeration solution allows you to keep that extra floor space with the impressive styling of freestanding refrigeration.



INTEGRATED

Our fridge freezer combinations or compact under-counter and in-column products can be hidden behind furniture doors. Choose fridges and freezers in different sizes and combinations depending on the space available and where you want to put them in your kitchen.





Professional Cooling Centre

Made from stainless steel both inside and out, the CAFF60 can be installed built-in or used as a freestanding fridge freezer with the addition of a pair of optional side panels [PANCAFF60].

PRODUCT CODE

CAFF60

DIMENSIONS

h:2129mm
w:1214mm
d:724.7mm
[inc. door - excl. handle]
d:778.7mm
[inc. door and handle]

PERFORMANCE

Energy class A++
Energy consumption
435kWh/yr
Max. noise level 48dB[A]
13kg/24hrs freezing
capacity

FINISH AVAILABLE

Stainless steel

FEATURES

- Argon filled triple glazed door
- Metal handles
- Plumbed internal automatic ice maker
- Filtered water supply for ice maker
- Electronic touch control with digital display
- 3 temperature zones
- Each fridge zone can be turned off independently
- Dual refrigeration system with 2 compressors and 3 evaporators
- 4 Star 216 litres, 2 star 31 litres
- Auto defrost
- Frost-free
- Super freeze and super cool functions
- Sabbath mode
- Open door alarm
- Forced air flow design

- Vegi-fresh compartment to keep vegetables fresh for longer
- Ambient humidity sensor for optimum performance
- Time and date display
- 100% CFC / HFC free
- Enhanced LED lighting through illuminated shelf supports
- Front access to levelling
- Can be installed built-in or freestanding with optional side panels [PANCAFF60]
- Climate class SN/T

DESIGN

- Stainless steel exterior and interior

STORAGE

- 6 Safety glass shelves
- 1 Sliding bottle tray
- 2 Freezer drawers
- 1 Crisper drawer

- 1 Ice compartment with ice maker
- 1 Glass marinating tray

CAPACITY

- 29 Cu ft/820 Litre total net capacity
- 25.2 Cu ft/713 Litre total gross capacity
- 16.5 Cu ft/466 Litre fridge net capacity
- 8.7 Cu ft/247 Litre freezer net capacity

OPTIONAL EXTRAS

- Pair of side panels for freestanding installation [PANCAFF60]
 - Replacement water filter [FILTER/CAFF60]
- Visit caple.co.uk for full range

INSTALLATION

- Diagram [p.240]

FEATURE RICH DESIGN

An argon filled triple glazed fridge compartment door allows you to see instantly what is in the fridge, which is further enhanced by subtle interior lights and illuminated shelf supports.

Supersized, super efficient and super stylish, the CAFF60, if your lucky enough to have the space in your kitchen, has everything you'd ever want in a large modern fridge freezer.

FREEZER AND FRIDGE ZONES

The CAFF60 has three separate temperature zones; one freezer and two fridge zones. The fridge zones are split into two. One behind the glazed door and the other one made up of the two fridge drawers directly below. All three zones can have different temperatures depending on your preference. The top fridge drawer also houses a veg-fresh compartment which is used to keep vegetables fresh for longer.

ELECTRONIC TOUCH CONTROLS

Each of the temperature zones can be controlled using the electronic touch control digital display. Other functions including date, time and a Sabbath mode can be easily accessed from this display panel too.

AUTOMATIC ICE MAKER

Convenience and capacity are very important when a fridge freezer like the CAFF60 is considered. Having a massive 820 litre total net capacity and the convenience of a filtered water ice maker, easily meets both requirements.

LED SHELF LIGHTING

Each shelf is enhanced by LED lighting acting as the shelf support. Not only does it give a dramatic look, it also ensures you can see exactly what your looking for.



PANCAFF60 SIDE PANEL



Freestanding Refrigeration

Convenience, additional storage and ease of use are the benefits of a French door fridge freezer compared to other types of refrigeration.

DOUBLE UP

Two freezer drawers gives you easy access to your food and with the capacity of 167L, the CAFF41 can freeze all your tasty treats until you need them.

FULL ILLUMINATION

The stylish backlight takes centre stage illuminating the entire fridge from top to bottom ensuring you can see all your fridge's contents quickly and easily.

STEEL TRIMMED INTERIOR

Glass shelves with deluxe steel trims to catch any spills.



INTERNAL LED LIGHTING AND TOUCH CONTROLS

Bold, well positioned LED lighting illuminate the interior of the fridge for excellent visibility while the touch controls provide quick access to all the handy functions.



WATER FILTERS

Fresh, great tasting filtered water supplied at the touch of a button. It improves the taste and odour by reducing chlorine, heavy metals and other sediments found in your tap water supply. It is located at the rear of the fridge compartment to allow easy access and it is quick to change with its simple, twist fit installation.



STYLISH VERSATILITY

The CAFF45GM features smart LED touch controls, cool gunmetal trim interior and four large capacity compartments, one of which can be used as a fridge or a freezer – the perfect combination of style and substance.

FOUR DOOR FRIDGE FREEZER



PRODUCT CODE

CAFF45GM

DIMENSIONS

h:1849mm
w:910mm
d:747mm
[inc. door - excl. handle]
d:796mm
[inc. door and handle]

PERFORMANCE

Energy class A+
Energy consumption
461kWh/yr
Max. noise level 46dB
Freezing capacity
13kg/24hrs

FINISH AVAILABLE

Gunmetal

FEATURES

- Super freeze and super cool functions
- Electronic touch control with LED display
- 4 Star freezer
- Frost-free
- High temperature alarm
- Open door alarm
- Holiday mode
- Eco mode
- Light sensor mode
- Drink chilling alarm
- Multi-air flow design in fridge and freezer compartments
- Self closing meat chiller compartment
- Child safety lock
- 100% CFC / HFC free
- Enhanced energy saving LED lighting
- Climate class T/N

DESIGN

- Gunmetal doors with grey cabinet
- Metal handles
- Gunmetal trimmed interior
- Metal back

STORAGE

- 2 Spill-capture adjustable glass shelves
- 1 Spill-proof shelf crisper lid
- 2 Salad crispers
- 1 Meat chiller compartment
- 2 Covered dairy compartments
- 6 Door storage racks
- 4 Freezer drawers, 2 compartments
- Ice cube tray
- Egg storage tray

CAPACITY

- 552 Litre total net capacity
- 630 Litre total gross capacity
- 390 Litre fridge net capacity
- 170 Litre freezer net capacity

INSTALLATION

- Diagram [p.241]

Features

LIGHT SENSOR MODE

Is an energy saving feature, which uses a sensor to recognise if there is sufficient light in the room to illuminate the fridge compartment, if so the internal lights do not switch on [this mode can be switch on or off].

FREEZER/FRIDGE COMPARTMENT

The bottom left compartment can be used as either fridge or freezer temperature storage.

FRENCH DOOR FRIDGE FREEZER



PRODUCT CODE

CAFF41

DIMENSIONS

h:1850mm
w:910mm
d:763mm
[inc. door - excl. handle]
d:812mm
[inc. door and handle]

PERFORMANCE

Energy class A+
Energy consumption
473kWh/yr
Max. noise level 45dB
Freezing capacity
20kg/24hrs

FINISH AVAILABLE

Stainless Steel

FEATURES

- Super freeze and super cool functions
- Electronic touch control with LED display
- 4 Star freezer
- Frost-free
- High temperature alarm
- Open door alarm
- Holiday mode
- Eco mode
- Drink chilling alarm
- Multi-air flow design in fridge and freezer compartments
- Self closing meat chiller compartment
- Child safety lock
- 100% CFC / HFC free
- Enhanced energy saving LED lighting
- Climate class T/N

DESIGN

- Stainless steel doors with grey cabinet
- Metal handles
- Steel trimmed interior

STORAGE

- 2 Spill-capture adjustable glass shelves
- 1 Spill-proof shelf crisper lid
- 2 Salad crispers
- 1 Meat chiller compartment
- 2 Covered dairy compartments
- 6 Door storage racks
- 2 Freezer drawers, 3 compartments
- Ice cube tray
- Egg storage tray

CAPACITY

- 557 Litre total net capacity
- 653 Litre total gross capacity
- 390 Litre fridge net capacity
- 167 Litre freezer net capacity

INSTALLATION

- Diagram [p.242]

SIDE-BY-SIDE FRIDGE FREEZER



PRODUCT CODE

CAFF23

DIMENSIONS

h:1751mm
w:922mm
d:700mm
[inc. door - excl. handle]
d:751mm
[inc. door and handle]

PERFORMANCE

e Energy class A+
Energy consumption
456kWh/yr
Max. noise level 45dB
Freezing capacity
15kg/24 hrs

FINISH AVAILABLE

 Stainless steel

FEATURES

- Super freeze and super cool functions
- Electronic touch control with LED display
- 4 Star freezer [2 star in door storage]
- Auto defrost
- Frost-free
- High temperature alarm
- Open door alarm
- Multi air flow system
- Child safety lock
- 100% CFC/HFC free
- Internal LED lights

DESIGN

- Stainless steel doors with a grey cabinet
- Metal curved handles

STORAGE

- 6 Spill-capture adjustable glass shelves
- 1 Spill-proof crisper lid
- 2 Salad crispers
- 1 Covered dairy compartment
- 9 Door storage racks
- 2 Freezer drawers

CAPACITY

- 20.55 Cu ft/582 Litre total net capacity
- 22.25 Cu ft/630 Litre total gross capacity
- 13.21 Cu ft/374 Litre fridge net capacity
- 7.35 Cu ft/208 Litre freezer net capacity

INSTALLATION

- Diagram [p.242]

SIDE-BY-SIDE FRIDGE FREEZERS



CAFF207SS

PRODUCT CODE

Stainless Steel CAFF207SS
Black CAFF207BK



DIMENSIONS

h:1751mm
w:923mm
d:700mm
[inc. door - excl. handle]
d:770mm
[inc. door and handle]

PERFORMANCE

e Energy class A+
Energy consumption
420kWh/yr
Max. noise level 45dB
Freezing capacity
12kg/24hrs

FINISH AVAILABLE

 Stainless steel
 Black

FEATURES

- In door ice and water dispenser
- Cubed and crushed ice
- Electronic control with LED display
- 4 Star [2 star in door storage]
- Auto defrost
- Frost-free
- Super freeze and super cool functions
- High temperature alarm
- Open door alarm
- Multi-air flow design
- Easyfit water filter cartridge located in the fridge compartment
- Child lock
- 100% CFC / HFC free
- Enhanced LED lighting
- Climate class SN-N-ST-T



CAFF207BK

DESIGN

- Stainless steel doors with a grey cabinet or black doors with a black cabinet
- Metal curved handles

STORAGE

- 5 Spill-capture adjustable glass shelves
- 2 Crispers
- 8 Door storage racks
- 1 Dairy compartment
- 2 Freezer drawers

CAPACITY

- 19.42 Cu ft/550 Litre total net capacity
- 22.25 Cu ft/630 Litre total gross capacity
- 12.85 Cu ft/364 Litre fridge net capacity
- 6.57 Cu ft/186 Litre freezer net capacity

OPTIONAL EXTRAS

- Replacement water filter [FILTER/CAFF205]
- Visit caple.co.uk for full range

INSTALLATION

- Diagram [p.242]

Features

ICE AND WATER?

Choose between crushed or cubed ice. Chilled, filtered water is also available at the touch of a button on our CAFF207 models that can be plumbed directly in to your kitchen.



Features

FRESH AIR FLOW TECHNOLOGY

The fan positioned at the top of the fridge circulates the cool air for even distribution keeping your food at the perfect temperature. Help preserve fresh foods for longer by adjusting the humidity in the crisper compartments.

FREESTANDING 70/30 FRIDGE FREEZER

PRODUCT CODE

RFF730

DIMENSIONS

h: 1860mm
w: 595mm
d: 650mm
[inc. door - excl. handle]

PERFORMANCE

Energy class A++
Energy consumption 263kWh/yr
Max. noise level 42dB [A]

FINISH AVAILABLE

Stainless Steel

GENERAL FEATURES

- Electronic touch control
- Independently electronic temperature control for fridge and freezer
- Energy saving display off option
- Easy to use control panel
- Right hand hinged door*
- Interior LED light
- Child lock
- Holiday mode
- Eco mode
- Feature metal handles
- High temperature alarm
- 100% CFC / HFC free
- Climate class T/SN

Fridge

- Auto defrost
- Super cool
- Fan cooled
- Humidity controlled fruit and veg drawer
- Chiller drawer for meat and fish
- Wine rack

Freezer

- Frost free
- Super freeze
- Drink cooling mode
- Safety stop drawers
- Freezing capacity 12kg/24hrs

STORAGE

- 2 Adjustable glass shelves
- 1 Glass cover shelf
- 1 Salad crisper
- 1 Humidity controlled drawer
- 1 Wine rack
- 3 Plastic door storage compartments
- 1 Egg tray
- 3 Freezer drawers
- 1 ice cube tray

CAPACITY

- 324 Litre total net capacity
- 341 Litre total gross capacity
- 94 Litre net freezer capacity
- 230 Litre net fridge capacity

INSTALLATION

- Diagram [p.243]

* The door is supplied RH hinged, it can be reversed. Please consult a qualified installation expert to reverse door configuration.

Integrated Refrigeration

Choose from tall column fridge or freezer combinations or compact under-counter models. How about an entirely separate fridge and freezer located in different spots around the kitchen? There are also tall all-in-one models that fit neatly into a single space.

Whatever you decide, it's reassuring to know that all of Caple's integrated refrigeration appliances have an A++ or A+ energy rating



FROST-FREE

No more laborious defrosting with a scraper. Our frost-free system works by heating up an element for a short time, which melts the ice and prevents build-up. Keeping a freezer ice-free means food stays fresher for longer. Freezing food is also much quicker, preserving as many nutrients as possible and freeing up much needed storage space.

FULLY ADJUSTABLE SHELF

Key features in the A++ rated RiL1795 fridge include a fully adjustable shelf in the door for true flexibility in your cooling appliance.

MODERN LIVING

The RiL1795 fridge and RiF1795 freezer have been designed with modern living in mind. The matching, in-column fridge and freezer are hidden behind your cabinet doors for an ultra neat finish in a contemporary or classic kitchen.

ENHANCED LIGHTING

LED strip lighting across the top and down each side of the fridge for a stylish, practical finish.

GLASS SHELVES

Some of which have a deluxe steel trims to catch any spills.

70/30 FRIDGE FREEZER – FROST-FREE



PRODUCT CODE

Ri7305

DIMENSIONS

 h:1770mm

PERFORMANCE

 Energy class A++
Energy consumption 226kWh/yr
Max. noise level 52dB[A]
4kg/24hrs freezing capacity

FINISH AVAILABLE

White

FEATURES

- Top and side LED strip lights
- Electronic controls
- Adjustable thermostat
- Auto defrost [Fridge]
- Frost free [Freezer]
- Super cooling and freezing mode
- Caple cool air-flow system
- Caple fresh
- Humidity controlled drawer
- Adjustable door balcony
- 100% CFC/HFC free
- Reversible door
- Sliding door installation

DESIGN

- Deluxe steel trimmed interior
- Transparent plastic drawers and compartments
- Climate class ST/N [16°C - 38°C]

STORAGE

- 3 Door storage compartments
- 1 adjustable door balcony
- 1 Drawer compartments [with humidity control for fruit and vegetable storage]
- 3 Removable glass shelves, 1 Crisper cover shelf
- 3 Freezer drawers
- 1 Egg tray
- 1 Ice tray

CAPACITY

- 243 Litre total net capacity
- 256 Litre total gross capacity
- 180 Litre fridge net capacity
- 63 Litre freezer net capacity

INSTALLATION

- Diagram [p.243]

Features

THE FRESHEST FOOD

Caple Fresh technology eliminates ethylene gas [a by-product of fresh foods] inside the vegetable drawer, therefore enabling your fresh food to last for longer. Caple's cool airflow system also ensures cold air will flow to every level for even chilling.

FROST-FREE

No more laborious defrosting with a scraper. Our frost-free system works by heating up an element for a short time, which melts the ice and prevents build-up. Keeping a freezer ice-free means food stays fresher for longer. Freezing food is also much quicker, preserving as many nutrients as possible and freeing up much needed storage space.

LED LIGHTING & ELECTRONIC CONTROLS

Strip LED lighting adds a modern feel, while electronic controls are precise and easy to use.



70/30 FRIDGE FREEZER



PRODUCT CODE

Ri7300

DIMENSIONS

 h:1770mm

PERFORMANCE

 Energy class A+
Energy consumption 269kWh/yr
Max. noise level 38dB[A]
4kg/24hrs freezing capacity

FINISH AVAILABLE

White

FEATURES

- Top LED light
- Manual controls
- Adjustable thermostat
- Auto defrost [Fridge]
- Humidity controlled drawer
- 100% CFC/HFC free
- Reversible door
- Sliding door installation

DESIGN

- Transparent plastic drawers and compartments

STORAGE

- 4 Door storage compartments
- 1 Drawer compartments [with humidity controls for fruit and vegetable storage]
- 3 Removable glass shelves, 1 Crisper cover shelf
- 3 Freezer drawers
- 1 Egg tray
- 1 Ice tray
- 1 Plastic ice scraper

CAPACITY

- 251 Litre total net capacity
- 256 Litre total gross capacity
- 181 Litre fridge net capacity
- 70 Litre freezer net capacity

INSTALLATION

- Diagram [p.243]

50/50 FRIDGE FREEZER – FROST-FREE



PRODUCT CODE

Ri5505

DIMENSIONS

h:1770mm

PERFORMANCE

e Energy class A++
Energy consumption
235kWh/yr
Max. noise level 43dB[A]
3kg/24hrs freezing
capacity

FINISH AVAILABLE

White

FEATURES

- Top LED strip light
- Electronic controls
- Adjustable thermostat
- Auto defrost [Fridge]
- Frost free [Freezer]
- Super cooling and freezing mode
- Caple cool air-flow system
- Caple fresh
- Humidity controlled drawer
- Adjustable door balcony
- 100% CFC/HFC free
- Reversible door
- Sliding door installation

DESIGN

- Deluxe steel trimmed interior
- Transparent plastic drawers and compartments

STORAGE

- 3 Door storage compartments
- 1 Drawer compartments [with humidity controls for fruit and vegetable storage]
- 3 Removable glass shelves, 1 Crisper cover shelf
- 4 Freezer drawers
- 1 Egg tray
- 1 Ice tray

CAPACITY

- 233 Litre total net capacity
- 249 Litre total gross capacity
- 148 Litre fridge net capacity
- 86 Litre freezer net capacity

INSTALLATION

- Diagram [p.243]

Features

FROST-FREE

No more laborious defrosting with a scraper. Our frost-free system works by heating up an element for a short time, which melts the ice and prevents build-up. Keeping a freezer ice-free means food stays fresher for longer. Freezing food is also much quicker, preserving as many nutrients as possible and freeing up much needed storage space.

GLASS SHELVES

Some of which have a deluxe steel trims to catch any spills.



50/50 FRIDGE FREEZER



PRODUCT CODE

Ri5500

DIMENSIONS

h:1770mm

PERFORMANCE

e Energy class A+
Energy consumption
277kWh/yr
Max. noise level 38dB[A]
5kg/24hrs freezing
capacity

FINISH AVAILABLE

White

FEATURES

- Top LED light
- Manual controls
- Adjustable thermostat
- Auto defrost [Fridge]
- Humidity controlled drawer
- 100% CFC/HFC free
- Reversible door
- Sliding door installation

DESIGN

- Transparent plastic drawers and compartments

STORAGE

- Door storage compartments
- 1 Drawer compartments [with humidity controls for fruit and vegetable storage]
- 3 Removable glass shelves, 1 Crisper cover shelf
- 4 Freezer drawers
- 1 Egg tray
- 1 Ice tray
- 1 Plastic ice scraper

CAPACITY

- 242 Litre total net capacity
- 249 Litre total gross capacity
- 148 Litre fridge net capacity
- 94 Litre freezer net capacity

INSTALLATION

- Diagram [p.243]

IN-COLUMN LARDER FRIDGE



PRODUCT CODE

RiL1795

DIMENSIONS

h:1770mm

PERFORMANCE

Energy class A++
Energy consumption
111kWh/yr
Max. noise 39dB [A]

FINISH AVAILABLE

White

FEATURES

- Matches RIF1795 freezer
- Top and side LED strip lights
- Electronic controls
- Adjustable thermostat
- Auto defrost
- Super cooling mode
- Caple cool air-flow system
- Caple fresh
- Humidity controlled drawer
- Easy adjustable door balcony
- 100% CFC/HFC free
- Reversible door
- Sliding door installation

DESIGN

- Deluxe steel trimmed interior
- Transparent plastic drawers and compartments

STORAGE

- 4 Standard door storage compartments
- 1 Easy adjustable door compartment
- 2 Drawer compartments [1 with humidity controls for fruit and vegetable storage]
- 1 bottle rack
- 4 Removable glass shelves
- 1 Glass drawer cover shelf
- 1 Egg tray

CAPACITY

- 300 Litre total net capacity
- 303 Litre total gross capacity

INSTALLATION

- Diagram [p.244]

Features

FRUIT & VEGETABLE PRESERVATION

The new Caple Fresh preservation technology inside the crisper drawer, ensures that your fruit and vegetables stay fresher and tastier for longer.

This innovative new system helps to eliminate the natural gases that are produced during the ripening and ageing process, preserving them for longer.

Also, the Caple Fresh preserver does not need to be replaced. It can be regenerated by exposing it to sunlight for one day a year.



IN-COLUMN FREEZER - FROST FREE



PRODUCT CODE

RiF1795

DIMENSIONS

h:1770mm

PERFORMANCE

Energy class A+
Energy consumption
297kWh/yr
Max. noise 41dB [A]
15kg / 24hr freezing capacity

FINISH AVAILABLE

White

FEATURES

- Matches RIL1795 fridge
- Top LED strip light
- Electronic controls
- Adjustable thermostat
- Frost free

- Twist Ice cube maker
- Super Freeze mode
- 4 star
- 100% CFC/HFC free
- Reversible door
- Sliding door installation

DESIGN

- Deluxe steel trimmed interior
- Transparent plastic drawers

STORAGE

- 6 Drawers
- 2 flip down door compartments
- 1 Ice cube tray
- 1 Twist ice cube maker

CAPACITY

- 197 Litre total net capacity
- 221 Litre total gross capacity

INSTALLATION

- Diagram [p.244]

Features

FROST-FREE

No more laborious defrosting with a scraper. Our frost-free system works by heating up an element for a short time, which melts the ice and prevents build-up. Keeping a freezer ice-free means food stays fresher for longer. Freezing food is also much quicker, preserving as many nutrients as possible and freeing up much needed storage space.

LED LIGHTING & ELECTRONIC CONTROLS

Strip LED lighting adds a modern feel, while electronic controls are precise and easy to use.



TWIST ICE CUBE MAKER

The new twist ice cube maker is a convenient way to make ice, with the added benefits of easy removal for cleaning for those times when you need the extra space.



IN-COLUMN LARDER FRIDGE



PRODUCT CODE

RiL124

DIMENSIONS

h:1220mm

PERFORMANCE

e Energy class A+
Energy consumption
128kWh/yr
Max. noise level 41dB[A]

FINISH AVAILABLE

White

FEATURES

- Matches RiF123 freezer
- Mechanically controlled
- Auto defrost
- Adjustable thermostat
- Interior LED light
- Sliding door installation
- Reversible door

DESIGN

- Deluxe steel trimmed interior
- Transparent plastic drawer and compartments

STORAGE

- 4 Removable glass shelves
- 1 Glass crisper cover shelf
- 1 Salad crisper
- 3 Plastic door storage compartments
- 1 Egg tray

CAPACITY

- 197 Litre total net capacity
- 208 Litre total gross capacity

INSTALLATION

- Diagram [p.244]

IN-COLUMN FREEZER



PRODUCT CODE

RiF123

DIMENSIONS

h:1220mm

PERFORMANCE

e Energy class
Energy consumption
216kWh/yr
Max. noise level 41dB[A]
6.5kg/24hrs freezing
capacity

FINISH AVAILABLE

White

FEATURES

- Matches RiL124 larder fridge
- Super freeze function
- Mechanically controlled
- 4 Star
- Manual defrost
- Adjustable thermostat
- Temperature alarm
- 100% CFC/HFC free
- Sliding door installation
- Reversible door

DESIGN

- Transparent blue plastic drawers

STORAGE

- 5 Drawers
- 1 Ice cube tray

CAPACITY

- 130 Litre total net capacity
- 145 Litre total gross capacity

INSTALLATION

- Diagram [p.244]

IN-COLUMN LARDER FRIDGE



PRODUCT CODE

RiL891

DIMENSIONS

h:880mm

PERFORMANCE

e Energy class A+
Energy consumption
120kWh/yr
Max. noise level 41dB[A]

FINISH AVAILABLE

White

FEATURES

- Matches RiF89 freezer
- Mechanically controlled
- Auto defrost
- Adjustable thermostat
- Interior light
- Sliding door installation
- Reversible door

DESIGN

- Deluxe steel trimmed interior
- Transparent plastic drawer and compartments

STORAGE

- 3 Removable glass shelves
- 1 Glass crisper cover shelf
- 1 Salad crisper
- 3 Plastic door storage compartments
- 1 Egg tray

CAPACITY

- 135 Litre total net capacity
- 144 Litre total gross capacity

INSTALLATION

- Diagram [p.244]

IN-COLUMN FREEZER



PRODUCT CODE

RiF89

DIMENSIONS

h:880mm

PERFORMANCE

e Energy class A+
Energy consumption
181kWh/yr
Max. noise level 41dB[A]
4.5kg/24hrs freezing
capacity

FINISH AVAILABLE

White

FEATURES

- Matches RiL891 larder fridge
- Super freeze function
- Mechanically controlled
- 4 Star
- Manual defrost
- Adjustable thermostat
- 100% CFC/HFC free
- Sliding door installation
- Reversible door

DESIGN

- Transparent blue plastic drawers

STORAGE

- 4 Drawers
- 1 Ice cube tray

CAPACITY

- 77 Litre total net capacity
- 93 Litre total gross capacity

INSTALLATION

- Diagram [p.244]



BUILT-UNDER FREEZER



BUILT-UNDER LARDER FRIDGE WITH ICE BOX



BUILT-UNDER LARDER FRIDGE



PRODUCT CODE

RBL4

DIMENSIONS

◀▶ w:595mm

PERFORMANCE

e Energy class A+
Energy consumption
115kWh/yr
Max. noise level
39dB[A]

FINISH AVAILABLE

White

FEATURES

- Matches RBF4 freezer
- Mechanically controlled
- Auto defrost
- Adjustable thermostat
- 100% CFC/HFC free
- Fixed door installation
- Reversible door
- Interior LED light

DESIGN

- Deluxe silver trimmed door balconies
- Transparent glass shelves and plastic compartments

STORAGE

- 2 Adjustable glass shelves
- 1 Glass crisper cover shelf
- 1 Salad crispers
- 2 Plastic door storage compartments
- 1 Egg tray

CAPACITY

- 133 Litre total net capacity
- 136 Litre total gross capacity

INSTALLATION

- Diagram [p.244]

PRODUCT CODE

RBF4

DIMENSIONS

◀▶ w:595mm

PERFORMANCE

e Energy class A+
Energy consumption
177kWh/yr
Max. noise level 41dB[A]
9kg/24hrs freezing capacity

FINISH AVAILABLE

White

FEATURES

- Matches RBL4 larder fridge
- Mechanically controlled
- 4 Star
- Manual defrost
- Adjustable thermostat
- 100% CFC/HFC free
- Reversible door
- Fixed door installation

DESIGN

- Transparent plastic drawers

STORAGE

- 3 Drawers
- 1 Ice cube tray

CAPACITY

- 93 Litre total net capacity
- 107 Litre total gross capacity

INSTALLATION

- Diagram [p.244]

PRODUCT CODE

RBR6

DIMENSIONS

◀▶ w:595mm

PERFORMANCE

e Energy class A+
Energy consumption
171kWh/yr
Max. noise level 39dB[A]
2kg/24hrs freezing capacity

FINISH AVAILABLE

White

FEATURES

- Matches RBF4 freezer
- Mechanically controlled
- Adjustable thermostat
- 100% CFC/HFC free
- Fixed door installation
- Reversible door
- Ice box open/closed indicator

Fridge

- Auto defrost
- Interior LED light

Ice Box

- 4 Star
- Manual defrost

DESIGN

- Deluxe silver trimmed door balconies
- Transparent glass shelves and plastic compartments

STORAGE

- 1 Glass shelf
- 1 Glass crisper cover shelf
- 1 Salad crisper
- 2 Plastic door storage compartments
- 1 Egg tray
- 1 Ice cube tray

CAPACITY

- 115 Litre total net capacity
- 120 Litre total gross capacity
- 98 Litre fridge net capacity
- 17 Litre ice box net capacity

INSTALLATION

- Diagram [p.244]



Look out for products marked with Sense Premium, Sense or Classic flags to easily identify the range.

sp s c

Wine Cabinets

Caple's wine cabinets create the optimum storage conditions for your wine; the correct temperature, humidity and air circulation. They even use low vibration technology to minimise disturbance.

And of course, they look great.

CARE FOR YOUR COLLECTION



TO STORE

All wine should be stored at 12-14°C whether red or white. Our cabinets simulate cellar conditions - dark, still, humid and a constant temperature.

TO SERVE

For rosés and whites it's 8-14°C, for sparkling wines it's 6-10°C. Full reds need 16-18°C, whereas lighter ones are best at 13-16°C. For some wine cabinets this temperature variation is a problem. However, Caple cabinets can offer multiple zones that keep all your wines at the perfect temperature for storing or better still, serving.

COMPRESSOR COOLING

When choosing a wine cabinet it's important to consider the type of cooling system it uses. Many conventional cabinets use thermo electric technology, which is only capable of cooling to 15°C below the room's ambient temperature. So on a warm day of 25°C the contents will only cool to a minimum of 10°C, leaving your wine exposed to potentially damaging temperatures.

Caple's wine cabinets use a compressor cooling system, which maintains precisely the right temperature, regardless of the ambient room temperature.

FINER WINE

Vibration and humidity during storage will influence how your wine will taste when it's finally poured. That's why Caple's wine cabinets come with anti-vibration gaskets and low vibration compressors to prevent disturbance to the wine's sediment balance. Our cabinets also create an ideal atmosphere of above 65% humidity, to preserve cork quality and prevent mould and odours. You can be confident your wine is in good hands.



THE IMPORTANCE OF LIGHTING AND STACKING

Ultraviolet light causes lightstrike, which makes wine age prematurely. So it's important to avoid exposing bottles to sunlight or fluorescent light. Our white LEDs not only look great, they are also UV-free with no heat output either.

Bottles should usually be stored on their side so the wine stays in contact with the cork. This keeps the cork moist and ensures a good air seal for the bottle, which prevents oxidation and immediate ageing.

Wine benefits best from side storage if the level of the wine reaches at least the upper shoulder of the bottle when upright. Caple's wine cabinets provide sufficient shelves to allow for bottles to be stored either on a single level for easy reach, or stacked for longer storage.



SENSE PREMIUM WINE CABINETS

TELESCOPIC SHELVES

The beech and stainless fronted telescopic wire shelves are gentle on the bottles, reducing any accidental scratches on the label and allowing you to easily view your collection. Perfect for Burgundy, Bordeaux and Champagne bottles.



AIR PURIFYING TECHNOLOGY

Charcoal filters eliminate odours and impurities in the air, preventing them from penetrating the cork, to ensure your collection is at its best when it comes to serving.



PREMIUM FUNCTIONALITY

Four light settings and four functions means you can find the right storage environment to suit your wine.



ON/OFF

Internal light is continuously on. Three minutes after closing the door the light will dim for a more subtle look.



DOOR OPENING LIGHT

Internal light will switch on when the door is opened, and off when the door is closed.



TIMER

This function keeps the lights on for 10 minutes once the door is closed and then switches off.



BRIGHTNESS

Once a light function is selected you can adjust the brightness of the internal lighting.



NORMAL MODE

The wine cabinet will operate with the temperatures you select.



ECO MODE

Lighting and control panel turns off and the compressor is delayed. Perfect for saving energy.



INTELLIGENT MODE

The fan speed adjusts according to the ambient temperature so the cabinet doesn't have to work as hard and also saves energy.



DEMO MODE

Primarily for Retail use. In this mode the compressor and heater are disabled and the fan input is reduced.



The Wi6160 undercounter integrated wine cabinet is the only one of its kind in Europe. Simply make a frame for the cabinet to match your kitchen furniture to create a seamlessly discreet and truly unique, luxurious style.

Look out for products marked with Sense Premium flags to easily identify the range.



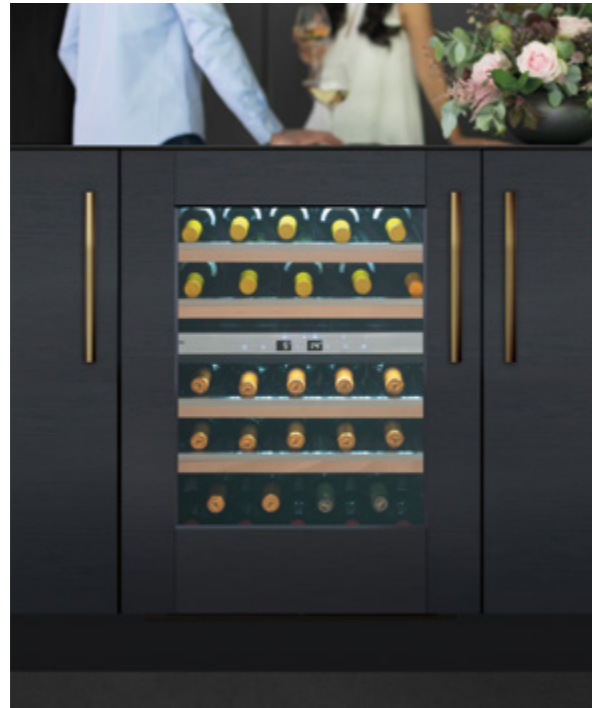

WI6160 - REQUIRES FURNITURE DOOR



WI6150

SENSE PREMIUM UNDERCOUNTER DUAL ZONE WINE CABINETS

PRODUCT CODE

- sp** Fully Integrated Wi6160
- sp** Stainless Steel Wi6150

DIMENSIONS

- w:** 595mm

WI6160 PERFORMANCE

- e** Energy class A+
- Energy consumption 109kWh/yr [Wi6160] 110kWh/yr [Wi6150]
- Ambient temperature 16°C-32°C
- Temperature range upper zone 5°C-10°C, lower zone 10°C-18°C
- Humidity range >65%RH
- Quiet operation 43dB[A]

FUNCTIONS

- 4** Light Functions
 - On/Off
 - Door opening Light
 - Timer
 - Brightness

4 Programme Settings

- Normal
- Eco
- Intelligent
- Demo

GENERAL FEATURES

- Shelves can accommodate 750ml Bordeaux, Burgundy and Champagne bottles
- No frost compressor cooling technology maintains a consistent temperature
- Dual stacked temperature zones, independently controlled [upper zone for serving, lower zone for storage]
- Touch controls and white LED display
- Converts into a can chiller using optional glass shelving
- Charcoal filter
- UV/heat-free white LED lighting [switchable]
- Vibration free
- Adjustable height to fit 100-150mm plinth
- Telescopic beech fronted wire shelves with steel trim
- Fan circulated cool air for even temperature distribution
- Reversible door

- Heater raises internal temperature when external temperature drops
- High temperature and open door alarm
- Upper zone has 2 sliding shelves
- Lower zone has 2 sliding shelves and 1 base shelf
- 100% CFC/HFC free
- Toughened UV protected glass door
- Black cabinet interior and exterior
- Recessed for fitting furniture plinth
- Air ventilation through plinth grille

WI6160 UNIQUE FEATURE

- Full furniture door with no window can be fitted
- Bespoke furniture door to match your kitchen cabinets required
- Supplied with stainless steel universal plinth grille w:525mm

WI6150 UNIQUE FEATURES

- One piece stainless steel door
- Stainless steel handle
- Supplied with stainless steel universal plinth grille w:525mm and full width grille

CAPACITY

- Wi6160 3.85 Cu Ft/109 Litre total net capacity
 - Wi6160 Stores max. 35 Bordeaux style wine bottles 750ml
 - Wi6150 4.27 Cu Ft/121 Litre total net capacity
 - Wi6150 Stores max. 44 Bordeaux style wine bottles 750ml
- Bottle stacking diagrams available at caple.co.uk

WI6160 OPTIONAL EXTRAS

- 1 Glass shelf [GSHELF3]
- Replacement carbon filter [WC1CF]

WI6150 OPTIONAL EXTRAS

- 1 Glass shelf [GSHELF2] Wi6150 only
- Replacement carbon filter [WC1CF]
- Filler panel [FP600SS] Visit caple.co.uk for full range

INSTALLATION

- Diagram [p.245]

SENSE PREMIUM UNDERCOUNTER SINGLE ZONE WINE CABINET



PRODUCT CODE

- sp** Wi3150

DIMENSIONS

- w:** 295mm

PERFORMANCE

- e** Energy class A+
- Energy consumption 107kWh/yr
- Ambient temperature 16°C-32°C
- Temperature range 5°C-18°C
- Humidity range >65%RH
- Quiet operation 43dB[A]

FINISH AVAILABLE

- Stainless steel

FUNCTIONS

- 4** Light Functions
 - On/Off
 - Door opening Light
 - Timer
 - Brightness

4 Programme Settings

- Normal
- Eco
- Intelligent
- Demo

GENERAL FEATURES

- Shelves can accommodate 750ml Bordeaux, Burgundy and Champagne bottles
- No-frost compressor cooling technology maintains a consistent temperature
- Single temperature zone stores red, white or sparkling wine
- Touch control and white LED display
- Converts into a can chiller using optional glass shelving
- Charcoal filter

- UV/heat-free white LED lighting [switchable]
- Vibration free
- Adjustable height to fit 100 - 150mm plinth
- Stainless steel handle
- Telescopic beech fronted wire shelves with steel trim
- Fan circulated cool air for even temperature distribution
- Reversible door
- High temperature and open door alarm
- 100% CFC/HFC free
- 5 Sliding shelves and 1 base shelf
- Toughened UV protected glass door
- One piece stainless steel door
- Black cabinet interior and exterior
- Recessed for fitting furniture plinth
- Air ventilation through plinth grille
- Supplied with both stainless steel universal plinth grille w:230mm and full width grille

CAPACITY

- 2.05 Cu Ft/58 Litre total net capacity
 - Stores max. 20 Bordeaux style wine bottles 750ml
- Bottle stacking diagrams available at caple.co.uk

OPTIONAL EXTRAS

- 1 Glass shelf [GSHELF1]
- Replacement carbon filter [WC1CF]
- Filler panel [FP300SS] Visit caple.co.uk for full range

INSTALLATION

- Diagram [p.245]

Features

TELESCOPIC SHELVES

The beech and stainless fronted telescopic wire shelves are gentle on the bottles, reducing any accidental scratches on the label and allowing you to easily view your collection. Perfect for Burgundy, Bordeaux and Champagne bottles.



CHARCOAL FILTERS

Charcoal filters eliminate odours and impurities in the air, preventing them from penetrating the cork, to ensure your collection is at its best when it comes to serving.



PREMIUM FUNCTIONALITY

Four light settings and four functions including Eco means you can find the right storage environment to suit your wine.

SENSE & CLASSIC WINE CABINETS

FILLER PANELS & PLINTHS

If you have a reduced plinth height you can use a filler panel made from the same material as the wine cabinet [stainless steel or black], to create a seamless look with no gap. A full plinth or recessed plinth grille option is available for our undercounter wine cabinets. They neatly cover the ventilation hole in the plinth and blend in with your kitchen décor.



DUAL ZONE

Dual zone wine cabinets allow you to store your collection at the perfect temperature for storing and drinking.

CHAMPAGNE SHELVES

The easy-slide beech shelves are non-scratch so they won't damage bottle labels. If Champagne is your drink of choice, the slatted design allows you to store larger bottles so you're prepared for any special occasion.

GLASS SHELVES

The glass shelves allow you to convert some of your wine cabinet into storage for canned drinks.



FILLER PANEL

FP300SS [Stainless steel - shown]
FP300BK [Black glass]

- w: 300mm
- Stainless steel or black glass
- Suitable for 300mm wine cabinets

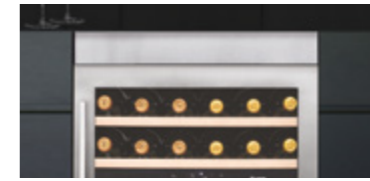

FILLER PANEL

FP600SS [Stainless steel - shown]
FP600BK [Black glass]

- w: 600mm
- Stainless steel or black glass
- Suitable for 600mm single door wine cabinets



FULL HEIGHT PLINTH GRILLE GRILL/CLASS150

- w: 150mm
- Stainless steel
- Suitable for 150mm wine cabinets



FULL HEIGHT PLINTH GRILLE GRILL/CLASS301

- w: 300mm
- Stainless steel
- Suitable for 300mm wine cabinets



FULL HEIGHT PLINTH GRILLE GRILL/CLASS601

- w: 600mm
- Stainless steel
- Suitable for 600mm wine cabinets



UNIVERSAL PLINTH GRILLE GRILL/SENSE600

- w: 525mm
- Stainless steel top fixing plinth grille



UNIVERSAL PLINTH GRILLE GRILL/SENSE6/GM

- w: 525mm
- Gunmetal top fixing plinth grille



UNIVERSAL PLINTH GRILLE GRILL/SENSE300

- w: 250mm
- Stainless steel top fixing plinth grille

Look out for products marked with Sense or Classic flags to easily identify the range.





SENSE AND CLASSIC UNDERCOUNTER DUAL ZONE WINE CABINETS



Wi6133GM



Wi6133

PRODUCT CODE

- S** Gunmetal Wi6133GM
- C** Stainless Steel Wi6133

DIMENSIONS

- w:595mm

PERFORMANCE

- e** Energy class B
- Energy consumption 198kWh/yr
- Ambient temperature 16°C - 32°C
- Temperature range upper zone 5°C - 10°C, lower zone 10°C - 18°C
- Humidity range >65%RH
- Quiet operation 43dB[A]

FINISH AVAILABLE

- Gunmetal
- Stainless steel

GENERAL FEATURES

- Shelves can accommodate 750ml Bordeaux, Burgundy and Champagne bottles
- No-frost compressor cooling technology maintains a consistent temperature
- Dual stacked temperature zones, independently controlled [upper zone serving, lower zone storage]
- Touch control and white LED display
- UV/heat-free white LED lighting [switchable]
- Vibration free
- Adjustable height to fit 100 - 150mm plinth
- Beech shelves
- Fan circulated cool air for even temperature distribution
- Reversible door
- Heater raises internal temperature when external temperature drops
- Upper zone has 2 sliding shelves
- Lower zone has 3 sliding shelves and 1 base shelf

- 100% CFC/HFC free
- Toughened UV protected glass door
- 2 Humidity control water tanks
- Black cabinet interior and exterior
- Recessed for fitting furniture plinth
- Air ventilation through plinth grille
- Supplied with both universal plinth grille w:525mm and full width grille

Wi6133GM UNIQUE FEATURES

- One piece gunmetal door
- Black square handle

Wi6133 UNIQUE FEATURES

- One piece stainless steel door
- Stainless steel square handle

CAPACITY

- 4.73 Cu Ft/134 Litre total net capacity
- 5.79 Cu ft/164 Litre total gross capacity
- Stores max. 46 Bordeaux style wine bottles 750ml [16 upper zone and 30 lower zone]
- Bottle stacking diagrams available at caple.co.uk

OPTIONAL EXTRAS

- Stainless steel square handle [HANDLE7] Wi6133GM
- Filler panel [FP600SS]
- Visit caple.co.uk for full range

INSTALLATION

- Diagram [p.245]

SENSE UNDERCOUNTER DUAL ZONE WINE CABINETS



Wi6134



Wi6134WH

PRODUCT CODE

- S** Black Glass Wi6134
- S** White glass Wi6134WH

DIMENSIONS

- w:595mm

PERFORMANCE

- e** Energy class B
- Energy consumption 198kWh/yr
- Ambient temperature 16°C - 32°C
- Temperature range upper zone 5°C - 10°C, lower zone 10°C - 18°C
- Humidity range >65%RH
- Quiet operation 43dB[A]

FINISH AVAILABLE

- Black glass
- White glass

GENERAL FEATURES

- Shelves can accommodate 750ml Bordeaux, Burgundy and Champagne bottles
- No-frost compressor cooling technology maintains a consistent temperature
- Dual stacked temperature zones, independently controlled [upper zone serving, lower zone storage]
- Touch control and white LED display
- UV/heat-free white LED lighting [switchable]
- Vibration free
- Adjustable height to fit 100 - 150mm plinth
- Stainless steel square handle
- Beech shelves
- Fan circulated cool air for even temperature distribution
- Reversible door
- Heater raises internal temperature when external temperature drops
- Upper zone has 2 sliding shelves
- Lower zone has 3 sliding shelves and 1 base shelf

- 100% CFC/HFC free
- Toughened UV protected glass door
- 2 Humidity control water tanks
- Black cabinet interior and exterior
- Recessed for fitting furniture plinth
- Air ventilation through plinth grille
- Supplied with stainless steel universal plinth grille w:525mm

Wi6134 UNIQUE FEATURES

- Black glass door with gloss black door frame

Wi6134WH UNIQUE FEATURES

- White glass door with white door frame

CAPACITY

- 4.73 Cu Ft/134 Litre total net capacity
- 5.79 Cu ft/164 Litre total gross capacity
- Stores max. 46 Bordeaux style wine bottles 750ml [16 upper zone and 30 lower zone]
- Bottle stacking diagrams available at caple.co.uk

OPTIONAL EXTRAS

- Full height stainless steel grille with fixing brackets [GRILL/CLASS601]
- Black square handle [HANDLE7BK]
- Filler panel [FP600BK] Wi6134 only
- Visit caple.co.uk for full range

INSTALLATION

- Diagram [p.245]

SENSE AND CLASSIC UNDERCOUNTER DUAL ZONE WINE CABINETS



WI6233

PRODUCT CODE

S	Black Glass	Wi6233
C	Stainless Steel	Wi6232

DIMENSIONS

w:595mm

PERFORMANCE

e Energy class B
 Energy consumption 195kWh/yr
 Ambient temperature 16°C - 32°C
 Temperature range 5°C - 18°C [both zones]
 Humidity range >65%RH
 Quiet operation 43dB[A]

FINISH AVAILABLE

- Black glass
- Stainless steel

- 100% CFC/HFC free
- Toughened UV protected glass door
- 2 Humidity control water tanks
- Black cabinet interior and exterior
- Recessed for fitting furniture plinth
- Air ventilation through plinth grille

WI6233 UNIQUE FEATURES

- Black glass doors with gloss black door frame
- Supplied with stainless steel universal plinth grille w:525mm

WI6232 UNIQUE FEATURES

- Stainless steel doors
- Supplied with both stainless steel universal plinth grille w:525mm and full width grille

GENERAL FEATURES

- Shelves can accommodate 750ml Bordeaux, Burgundy and Champagne bottles
- No-frost compressor cooling technology maintains a consistent temperature
- Dual side-by-side temperature zones, independently controlled [both zones suitable for either serving or storage]
- Touch controls and white LED display
- Converts into a can chiller using optional glass shelving
- UV/heat-free white LED lighting [switchable]
- Vibration free
- Adjustable height to fit 100-150mm plinth
- Stainless steel square handles
- Beech shelves
- Fan circulated cool air for even temperature distribution
- 5 Sliding shelves and 1 base shelf per zone

CAPACITY

- 4.20 Cu ft/119 Litre total net capacity
- 4.73 Cu ft/134 Litre total gross capacity
- Stores max. 38 Bordeaux style wine bottles 750ml [19 bottles per zone]
- Bottle stacking diagrams available at caple.co.uk

OPTIONAL EXTRAS

- 3 Frosted glass shelves with black plastic trim [GSHELFPAK/300]
- Full height stainless steel grille with fixing brackets [GRILL/CLASS601] for Wi6233 only
- Black square handle, 2 required [HANDLE7BK] Visit caple.co.uk for full range

INSTALLATION

- Diagram [p.245]



WI6232

SENSE AND CLASSIC UNDERCOUNTER SINGLE ZONE WINE CABINETS



WI6141

PRODUCT CODE

S	Black Glass	Wi6141
C	Stainless Steel	Wi6140

DIMENSIONS

w:595mm

PERFORMANCE

e Energy class A
 Energy consumption 145kWh/yr
 Ambient temperature 16°C - 32°C
 Temperature range 5°C - 18°C
 Humidity range >65%RH
 Quiet operation 43dB[A]

FINISH AVAILABLE

- Black glass
- Stainless steel

GENERAL FEATURES

- Shelves can accommodate 750ml Bordeaux, Burgundy and Champagne bottles
- No-frost compressor cooling technology maintains a consistent temperature
- Single temperature zone stores red, white or sparkling wine
- Touch controls and white LED display
- Converts into a can chiller using optional glass shelving
- UV/heat-free white LED lighting [switchable]
- Vibration free
- Adjustable height to fit 100-150mm plinth
- Stainless steel square handle
- Beech shelves
- Fan circulated cool air for even temperature distribution
- Reversible door
- 5 Sliding shelves and 1 base shelf
- 100% CFC/HFC free
- Toughened UV protected glass door
- Humidity control water tanks



WI6140

GENERAL FEATURES

- Black cabinet interior and exterior
- Recessed for fitting furniture plinth
- Air ventilation through plinth grille

WI6141 UNIQUE FEATURES

- Black glass doors with gloss black door frame
- Supplied with stainless steel universal plinth grille w:525mm

WI6140 UNIQUE FEATURES

- One piece stainless steel door
- Supplied with both stainless steel universal plinth grille w:525mm and full width grille

CAPACITY

- 5.15 Cu Ft/146 Litre total net capacity
- 5.79 Cu ft/164 Litre total gross capacity
- Stores max. 52 Bordeaux style wine bottles 750ml [8 bottles per sliding shelf, 6 bottles on base shelf, 14 on top shelf]
- Bottle stacking diagrams available at caple.co.uk

OPTIONAL EXTRAS

- 3 Frosted glass shelves with black plastic trim [GSHELFPAK/600]
- Full height stainless steel grille with fixing brackets [GRILL/CLASS601] for Wi6141 only
- Filler panel [FP600BK] for Wi6141 only
- Filler panel [FP600SS] for Wi6140 only
- Black square handle [HANDLE7BK] Visit caple.co.uk for full range

INSTALLATION

- Diagram [p.245]

SENSE AND CLASSIC UNDERCOUNTER SINGLE ZONE WINE CABINETS



Wi3124

PRODUCT CODE

S	Black glass	Wi3124
C	Stainless steel	Wi3123
S	White glass	Wi3124WH

DIMENSIONS

w:295mm

PERFORMANCE

e Energy class A
 Energy consumption 140kWh/yr
 Ambient temperature 16°C - 32°C
 Temperature range 5°C - 18°C
 Humidity range >65%RH
 Quiet operation 43dB[A]

FINISH AVAILABLE

	Black glass
	Stainless steel
	White glass

GENERAL FEATURES

- Shelves can accommodate 750ml Bordeaux, Burgundy and Champagne bottles
- No-frost compressor cooling technology maintains a consistent temperature
- Single temperature zone stores red, white or sparkling wine
- Touch controls and white LED display
- Converts into a can chiller using optional glass shelving
- UV/heat-free white LED lighting [switchable]
- Vibration free
- Adjustable height to fit 100-150mm plinth
- Stainless steel handle
- Beech shelves
- Fan circulated cool air for even temperature distribution
- Reversible door
- 5 Sliding shelves and 1 base shelf
- 100% CFC/HFC free
- Toughened UV protected glass door
- Humidity control water tank
- Black cabinet interior and exterior
- Recessed for fitting furniture plinth

Wi3124 UNIQUE FEATURES

- Black glass door with gloss black door frame
- Supplied with stainless steel universal plinth grille w:230mm

Wi3123 UNIQUE FEATURES

- One piece stainless steel door
- Supplied with both stainless steel universal plinth grille w:230mm and full width grille

Wi3124WH UNIQUE FEATURES

- White glass doors with gloss white door frame
- Supplied with stainless steel universal plinth grille w:230mm

CAPACITY

- 1.98 Cu Ft/56 Litre total net capacity
- 2.33 Cu ft/66 Litre total gross capacity
- Stores max.19 Bordeaux style wine bottles 750ml
 Bottle stacking diagrams available at caple.co.uk

OPTIONAL EXTRAS

- 3 Frosted glass shelves with black plastic trim [GSHELFPAK/300]
- Full height stainless steel grille with fixing brackets [GRILL/CLASS301] for Wi3124 and Wi3124WH
- Black square handle [HANDLE7BK]
- Filler panel [FP300BK] for Wi3124 only
- Filler panel [FP300SS] for Wi3123 only
 Visit caple.co.uk for full range

INSTALLATION

- Diagram [p.245]



Wi3123



Wi3124WH

SENSE AND CLASSIC UNDERCOUNTER SINGLE ZONE WINE CABINETS



Wi156

PRODUCT CODE

S	Black Glass	Wi156
C	Stainless Steel	Wi157

DIMENSIONS

w:145mm

PERFORMANCE

e Energy class A
 Energy consumption 135kWh/yr
 Ambient temperature 16°C - 32°C
 Temperature range 5°C - 18°C
 Humidity range >65%RH
 Quiet operation 44dB[A]

FINISH AVAILABLE

	Black glass
	Stainless steel

FEATURES

- No-frost compressor cooling technology maintains a consistent temperature
- Single temperature zone stores red, white or sparkling wine
- Electronic temperature control and LED display
- UV/heat-free white LED lighting [switchable]
- Vibration free
- Adjustable height to fit 100 - 150mm plinth
- Wooden bottle rack
- Stainless steel square handle
- Fan circulated cool air for even temperature distribution
- Reversible door
- 6 Black wire shelves and 1 base shelf
- 100% CFC/HFC free
- Toughened UV protected glass door
- Black cabinet interior and exterior
- Air ventilation through plinth grille



Wi157

Wi156 UNIQUE FEATURES

- Black glass door with gloss black door frame
- Supplied with stainless steel universal plinth grille w:144mm

Wi157 UNIQUE FEATURES

- One piece stainless steel door
- Supplied with both stainless steel universal plinth grille w:144mm and full width grille

CAPACITY

- 0.81 Cu ft/23 Litre total net capacity
- 0.88 Cu ft/25 Litre total gross capacity
- Stores max. 8 Bordeaux style wine bottles 750ml
- Not suitable for champagne bottles
 Bottle stacking diagrams available at caple.co.uk

OPTIONAL EXTRAS

- Black square handle [HANDLE7BK]
- Full height stainless steel grille with fixing brackets [GRILL/CLASS150] for Wi156 only
 Visit caple.co.uk for full range

INSTALLATION

- Diagram [p.245]

SENSE AND CLASSIC IN-COLUMN TRIPLE ZONE WINE CABINETS



WC1796



WC1792 AND SSDOOR177

PRODUCT CODE

- S** Black Glass WC1796
- C** Stainless Steel WC1792

DIMENSIONS

- h:1788mm

FINISH AVAILABLE

- Black glass
- Stainless steel

PERFORMANCE

- Energy class A
- Energy consumption 158kWh/yr
- Ambient temperature 16°C - 32°C
- Temperature range upper zone 5°C - 18°C, middle zone 5°C - 10°C, lower zone 10°C - 18°C
- Humidity range >65%RH
- Quiet operation 45dB[A]

FEATURES

- Shelves can accommodate 750ml Bordeaux, Burgundy and Champagne bottles
- No-frost compressor cooling technology maintains a consistent temperature
- Triple stacked temperature zones, independently controlled for storage or serving
- Touch control and white LED display
- UV/heat-free white LED lighting [switchable]
- Vibration free
- Square stainless steel handle
- Telescopic beech shelves
- Fan circulated cool air for even temperature distribution
- Reversible door
- High temperature and open door alarm
- 2 Heaters raise internal temperature when external temperature drops
- Upper zone has 2 sliding shelves and 1 display shelf
- Middle zone has 3 sliding shelves and 1 display shelf

- Lower zone has 3 sliding shelves and 1 base shelf
- Double stacked shelves
- 100% CFC/HFC free
- Toughened UV protected glass door
- 3 Humidity control water tanks
- Black cabinet interior and stainless steel back panel
- Air ventilation through plinth grille
- Supplied with stainless steel universal plinth grille w:525mm

WC1796 UNIQUE FEATURES

- Black glass doors with gloss black door frame

WC1792 UNIQUE FEATURES

- One piece stainless steel door

CAPACITY

- 8.69 Cu ft/246 Litre total net capacity
- 10.14 Cu ft/287 Litre total gross capacity
- Stores max. 89 Bordeaux style wine bottles 750ml [29 bottles on upper zone, 25 bottles on middle zone and 35 bottles on lower zone]
- Bottle stacking diagrams available at caple.co.uk

OPTIONAL EXTRAS

- Square black handle [HANDLE7BK] for WC1796
- Furniture doors [SSDOOR177] for WC1792
- Visit caple.co.uk for full range

INSTALLATION

- Diagram [p.246]

Features

TELESCOPIC SHELVES

The easy-slide beech shelves are non-scratch so they won't damage bottle labels. If champagne is your drink of choice, the slatted design allows you to store larger bottles so you're prepared for any special occasion.



SENSE AND CLASSIC IN-COLUMN DUAL ZONE WINE CABINETS

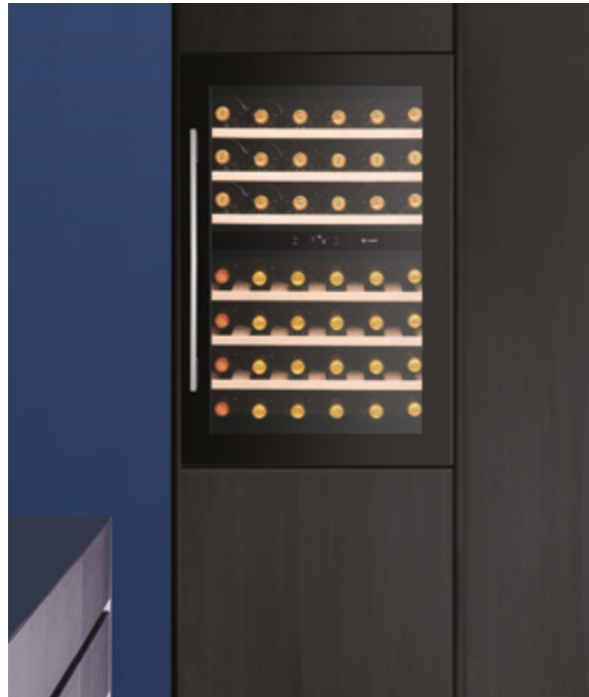

WC6520

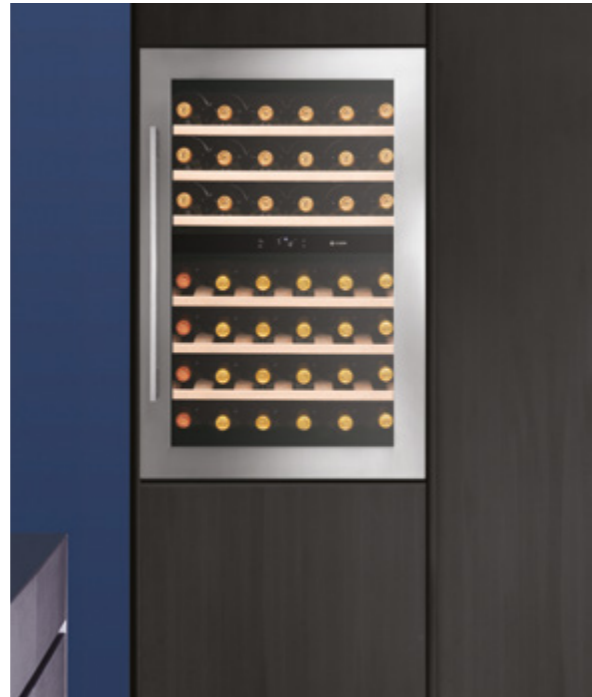

WC6510

PRODUCT CODE

- S** Black Glass WC6520
- C** Stainless Steel WC6510

DIMENSIONS

- h:886mm

PERFORMANCE

- e** Energy class B
- Energy consumption 198kWh/yr
- Ambient temperature 16°C - 32°C
- Temperature range upper zone 5°C - 10°C, lower zone 10°C - 18°C
- Humidity range >65%RH
- Quiet operation 45dB[A]

FINISH AVAILABLE

- Black glass
- Stainless steel

FEATURES

- Shelves can accommodate 750ml Bordeaux, Burgundy and Champagne bottles
- No-frost compressor cooling technology maintains a consistent temperature
- Dual stacked temperature zones, independently controlled [upper zone to serve, lower zone storage]
- Touch controls and white LED display
- UV/heat-free white LED lighting [switchable]
- Vibration free
- Stainless steel square handle
- Beech shelves
- Fan circulated cool air for even temperature distribution
- Reversible door
- Heater raises internal temperature when external temperature drops
- High temperature and open door alarm

- Upper zone has 3 sliding shelves
- Lower zone has 3 sliding shelves and 1 sliding base shelf
- 100% CFC/HFC free
- Toughened UV protected glass door
- 2 Humidity control water tanks
- Black cabinet interior and exterior

WC6520 UNIQUE FEATURE

- Black glass doors with gloss black door frame

WC6510 UNIQUE FEATURES

- One piece stainless steel door

CAPACITY

- 4.13 Cu ft/117.1 Litre total net capacity
 - 4.94 Cu ft/140.1 Litre total gross capacity
 - Stores max. 41 Bordeaux style wine bottles 750ml [18 white bottles on upper zone, and 23 red bottles on lower zone]
- Bottle stacking diagrams available at caple.co.uk

OPTIONAL EXTRAS

- Black square handle [HANDLE7BK]

INSTALLATION

- Diagram [p.246]

CLASSIC IN-COLUMN SINGLE ZONE WINE CABINET

PRODUCT CODE

- C** WC6500

DIMENSIONS

- h:886mm

FINISH AVAILABLE

- Stainless Steel

PERFORMANCE

- e** Energy class A
- Energy consumption 146kWh/yr
- Ambient temperature 16°C - 32°C
- Temperature range 5°C - 18°C
- Humidity range >65%RH
- Quiet operation 45dB[A]

FEATURES

- Shelves can accommodate 750ml Bordeaux, Burgundy and Champagne bottles
- No-frost compressor cooling technology maintains a consistent temperature
- Single temperature zone stores red, white or sparkling wine
- Touch controls and white LED display
- UV/heat-free white LED lighting [switchable]
- Vibration free
- Stainless steel square handle
- One piece stainless steel door
- Beech shelves
- Fan circulated cool air for even temperature distribution
- Reversible door
- High temperature and open door alarm
- 7 Sliding shelves and 1 base shelf
- 100% CFC/HFC free
- Toughened UV protected glass door
- Humidity control water tank
- Black cabinet interior and exterior

CAPACITY

- 4.38 Cu ft/124 Litre total net capacity
 - 5.41 Cu ft/153 Litre total gross capacity
 - Stores max. 47 Bordeaux style wine bottles 750ml
- Bottle stacking diagrams available at caple.co.uk

INSTALLATION

- Diagram [p.246]





SENSE AND CLASSIC IN-COLUMN SINGLE ZONE WINE CABINETS

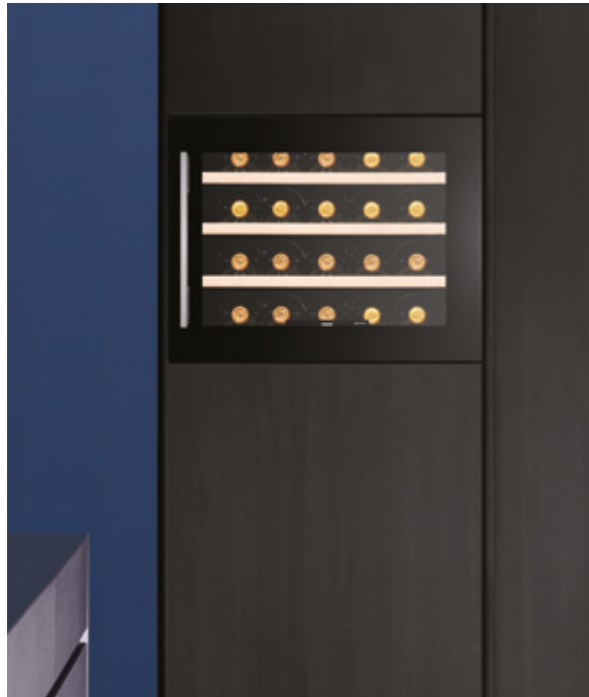

WC6410



WC6400

PRODUCT CODE

- S** Black Glass WC6410
- C** Stainless Steel WC6400

DIMENSIONS

- h:455mm

FINISH AVAILABLE

- Black glass
- Stainless steel

PERFORMANCE

- e** Energy class A
- Energy consumption 139kWh/yr
- Ambient temperature 16°C - 32°C
- Temperature range 5°C - 18°C
- Humidity range >65%RH
- Quiet operation 43dB[A]

FEATURES

- Shelves can accommodate 750ml Bordeaux, Burgundy and Champagne bottles
- No-frost compressor cooling technology maintains a consistent temperature
- Single temperature zone for red, white or sparkling wine
- Touch control and white LED display
- UV/heat-free white LED lighting [switchable]
- Vibration free
- Stainless steel square handle
- Beech shelves
- Fan circulated cool air for even temperature distribution
- Reversible door
- High temperature and open door alarm
- 3 Sliding shelves and 1 base shelf
- 100% CFC/HFC free
- Toughened UV protected glass door
- Humidity control water tank
- Black cabinet interior and exterior

WC6410 UNIQUE FEATURES

- Black glass doors with gloss black door frame

WC6400 UNIQUE FEATURES

- One piece stainless steel door

CAPACITY

- 1.91 Cu ft/54 Litre total net capacity
- 2.08 Cu ft/59 Litre total gross capacity
- Stores max. 21 Bordeaux style wine bottles 750ml
- Bottle stacking diagrams available at caple.co.uk

INSTALLATION

- Diagram [p.246]



SENSE FREESTANDING TRIPLE ZONE WINE CABINET

PRODUCT CODE

- S** WF1549

DIMENSIONS

- h:1762mm

FINISH AVAILABLE

- Black glass

PERFORMANCE

- e** Energy class C
- Energy consumption 290kWh/yr
- Ambient temperature 16°C - 32°C
- Temperature range upper zone 5°C - 18°C, middle zone 5°C - 12°C, lower zone 12°C - 18°C
- Humidity range >65%RH
- Quiet operation 45dB[A]

FEATURES

- Shelves can accommodate 750ml Bordeaux, Burgundy and Champagne bottles
- No-frost compressor cooling technology maintains a consistent temperature
- Triple stacked temperature zones, independently controlled for storage or serving
- Electronic temperature control and LED display
- UV/heat-free white LED lighting [switchable]
- Vibration free
- Black glass door with gloss black door frame
- Stainless steel, black-spot feature bar handle
- Telescopic shelves
- Fan circulated cool air for even temperature distribution
- 2 Heaters raise internal temperature when external temperature drops

REVERSIBLE DOOR

- Reversible door
- Door lock
- Upper zone has 1 sliding shelf and 1 display shelf
- Middle zone has 2 sliding shelves and 1 display shelf
- Lower zone has 3 sliding shelves and 1 base shelf
- 100% CFC/HFC free
- Toughened UV protected glass door
- 3 Humidity control water tanks
- Black cabinet interior and exterior
- Air ventilation through plinth grille

CAPACITY

- 14.23 Cu ft/404 Litre total net capacity
- 15.86 Cu ft/449 Litre total gross capacity
- Stores max. 132 Bordeaux style wine bottles 750ml [43 bottles on upper zone, 45 bottles on middle zone and 44 bottles on lower zone]

INSTALLATION

- Diagram [p.246]



CLASSIC FREESTANDING TRIPLE ZONE WINE CABINET

PRODUCT CODE

c WF1548

DIMENSIONS

d h:1762mm

PERFORMANCE

e Energy class C
 Energy consumption 290kWh/yr
 Ambient temperature 16°C - 32°C
 Temperature range upper zone 5°C - 18°C, middle zone 5°C - 12°C, lower zone 12°C - 18°C
 Humidity range >65%RH
 Quiet operation 45dB[A]

FINISH AVAILABLE

Stainless steel

FEATURES

- Shelves can accommodate 750ml Bordeaux, Burgundy and Champagne bottles
- No-frost compressor cooling technology maintains a consistent temperature
- Triple stacked temperature zones, independently controlled for storage or serving
- Electronic temperature control and white LED display
- UV/heat-free white LED lighting [switchable]
- Vibration free
- Curved stainless steel handle
- One piece stainless steel door
- Stainless steel fronted telescopic beech shelves
- Fan circulated cool air for even temperature distribution
- 2 Heaters raise internal temperature when external temperature drops
- Reversible door
- Door lock

- Upper zone has 1 sliding shelf and 1 display shelf
- Middle zone has 2 sliding shelves and 1 display shelf
- Lower zone has 3 sliding shelves and 1 base
- 100% CFC/HFC free
- Toughened UV protected glass door
- 3 Humidity control water tanks
- Black cabinet interior and exterior
- Air ventilation through stainless steel plinth grille

CAPACITY

- 14.23 Cu ft/404 Litre total net capacity
- 15.86 Cu ft/449 Litre total gross capacity
- Stores max. 132 Bordeaux style wine bottles 750ml [43 bottles on upper zone, 45 bottles on middle zone and 44 bottles on lower zone]

INSTALLATION

- Diagram [p.246]



CLASSIC FREESTANDING SINGLE ZONE WINE CABINET

PRODUCT CODE

c WF333

DIMENSIONS

d h:840mm

PERFORMANCE

e Energy class A
 Energy consumption 144kWh/yr
 Temperature range 5°C - 18°C
 Ambient temperature 16°C - 32°C
 Humidity range >65%RH
 Quiet operation 44dB[A]

FINISH AVAILABLE

Stainless steel

FEATURES

- No-frost compressor cooling technology maintains a consistent temperature
- Single temperature zone for red or white wine
- Electronic temperature control and white LED display
- Curved stainless steel handle
- One piece stainless steel door
- Stainless steel fronted telescopic beech shelves
- Reversible door
- Interior light
- 3 Double stacked shelves and 1 half shelf
- 100% CFC/HFC free
- Toughened UV protected glass door
- Humidity control water tank
- Black cabinet interior and exterior
- Top and side heat dispersion

CAPACITY

- 4.39 Cu ft/124 Litre total net capacity
- 4.87 Cu ft/138 Litre total gross capacity
- Stores max. 39 Bordeaux style wine bottles 750ml [6 bottles on top shelf, 12 bottles double stacked on middle two shelves and 9 bottles double stacked on the bottom shelf]

INSTALLATION

- Diagram [p.246]



WASHING

DISHWASHERS	202
WASHING MACHINES	212
WASHER DRYER	214
TUMBLE DRYERS	216

WASHING

198
199



Taking the chore out of washing

Who says that functional objects can't look fantastic?
That's why we've designed our dishwasher and laundry
appliances with an eagle eye on performance and style

Caple is renowned for ultra stylish looks, hi-tech and all-round ease
of use. With fast, efficient clothes washing and drying and sparkling
clean dishes, our appliances will always get the job done beautifully
with minimal effort.

WASH HOWEVER YOU WISH

Our range of washing appliances gives you all the options you
need to fit in with your kitchen and your budget. What's on
your wish list? An appliance that makes the most of minimal
space? One that can cope with a large family? Or super
stylish looks? We tick all your boxes.



Our dishwashers are exceptionally versatile, using clever
technology to deal with any type of load. Our washing
machines and washer dryers make light work of all your
laundry needs with features like allergy care, stain reduction
and extra large doors. What's more, Caple tumble dryers can
be kept neatly behind furniture doors for a flawless finish.



Dishwashers

Our machines don't just leave your dishes sparkling, they also come with at least an A+ rating for energy and A for wash and drying performance.

PERFORMANCE WITH SHINE

Whether it's a quick wash or something more heavy-duty, every Caple dishwasher is designed to perform well. All models are fully integrated to tuck away behind your kitchen doors and are at least A+ energy rated, with the top of the range model now an amazing A+++.

WATER CONSUMPTION

The entire range has low water consumption figures, which is not only great for the environment but your pocket also. The Auto Wash programme on the Di491 uses an astonishingly low 8 litres of water.



POWER WASH AND AUTO WASH

Exclusive to the Di651. Power Wash, when used with either intensive, normal, economy, glass and one hour express programmes, helps break through heavily soiled loads by increasing washing temperature and duration.

Auto wash on Di651 and Di491 have sensors checking the level of cleanliness of the load, saving you time, energy and water.



ADJUSTABLE UPPER BASKET

Look out for models with adjustable upper basket. You can change the height of the upper basket [even with full loads] with the simple release of two conveniently placed levers.



ALTERNATIVE WASH

Available on a selection of models the alternative wash allows you to select either the upper or lower baskets for the load. You'll save water and energy with smaller loads.



INTERNAL LED LIGHT

Activated when the door is opened, it illuminates the inside.



DELAY TIMER

Allows you to delay the start time for between 1-24 hours.

REDUCE YOUR WATER AND ENERGY USAGE

The Half Load function on our models is ideally suited to small loads, unlike traditional Half Load programmes [which usually only use one basket] reducing energy and water use.

AQUASTOP

Automatically cuts off the water at the first sign of a leak, helping to avoid costly water damage.

Features

FLEXIBLE CUTLERY TRAY

Why not opt for an adjustable cutlery tray. The tray sits at the top of the dishwasher freeing up more space in the lower basket. On the

600mm models you can choose from five set-up options, [shown below] depending on what is in the basket below.





FULLY INTEGRATED DISHWASHER



PRODUCT CODE

Di651

DIMENSIONS

↔ w:600mm

PERFORMANCE

e Energy class A+++
 Wash Class A
 Drying performance A
 Max. noise level 40dB[A]
 Annual energy consumption 241kWh/yr
 Annual water consumption 2800 Litres
 Water consumption [economy] from 10 Litres
 Energy consumption per cycle [economy] 0.84kWh

FINISH AVAILABLE

■ Stainless steel control panel with LCD display

PROGRAMMES

7 Programmes
 *Normal/55°C
 *Intensive/60°C
 *Economy/45°C
 90min express/65°C
 Auto/45-55°C
 Glass/40°C
 Rapid/45°C

FUNCTIONS

- Express wash
- Extra drying / Turbo drying
- Power wash
- Alternative wash
- Delayed timer 1-24hr

FEATURES

- 15 Place settings
- Max. plate diameter 30cm
- Stainless steel inner door and interior
- Stainless steel direct touch control panel
- Programme status light
- Internal light
- Top cutlery tray
- Titanium grey baskets
- Electronic salt and rinse aid warning light
- Cold water connection
- 3 spray levels
- Hidden heating element
- Easy adjustable upper basket
- Sliding door dispenser
- Easy clean filter system
- 6 Level water softening system
- Water overflow protection system
- Aquastop

INSTALLATION

- Diagram [p.247]
- Voltage 220-240V
- Rated load 1.93kW
- Fuse rating 10A

Features

Due to the whisper quiet nature of the Di651, this appliance has a convenient programme status light [shown below] projecting onto the floor during the cycle. This light turns off when complete.



EASY ADJUSTABLE UPPER BASKET



FULLY INTEGRATED DISHWASHER



PRODUCT CODE

Di641

DIMENSIONS

w:600mm

PERFORMANCE

e Energy class A++
Wash Class A
Drying performance A
Max. noise level 47dB
Annual energy consumption 266kWh/yr
Annual water consumption 2800 Litres
Water consumption [economy] 10 Litres

FINISH AVAILABLE

Stainless steel control panel with electronic display

PROGRAMMES

7 Programmes
Normal/55°C
Intensive/65°C
Economy/45°C
90min express/60°C
Glass/40°C
Rapid/40°C
Soak

FUNCTIONS

- Delayed timer 1-24hr
- Half load

FEATURES

- 14 Place settings
- Max. plate diameter 30cm
- Stainless steel inner door and interior
- Top cutlery tray
- Titanium grey baskets
- Cold water connection
- Hidden heating element
- Easy adjustable upper basket
- Easy clean filter system
- Electronic salt and rinse aid warning light
- 6 Level water softening system
- Water overflow protection system
- Aquastop

INSTALLATION

- Diagram [p.247]
- Voltage 230V
- Rated load 1.93kW
- Fuse rating 13A

FULLY INTEGRATED DISHWASHER



PRODUCT CODE

Di631

DIMENSIONS

w:600mm

PERFORMANCE

e Energy class A++
Wash Class A
Drying performance A
Max. noise level 49dB
Annual energy consumption 258kWh/yr
Annual water consumption 3080 Litres
Water consumption [economy] 11 Litres
Energy consumption per cycle [economy] 0.91kWh

FINISH AVAILABLE

Black gloss door top control panel

PROGRAMMES

5 Programmes
Normal/55°C
Intensive/65°C
Economy/50°C
1 hour/60°C
Rapid/40°C

FUNCTIONS

- Delay timer 3, 6 or 9hrs

FEATURES

- 12 Place settings
- Max. plate diameter 30cm
- Stainless steel inner door and interior
- Titanium grey baskets
- Salt and rinse aid warning light
- Cold water connection
- Hidden heating element
- Adjustable upper basket
- Easy clean filter system
- 6 Level water softening system
- Water overflow protection system

INSTALLATION

- Diagram [p.247]
- Voltage 230V
- Rated load 1.93kW
- Fuse rating 13A

FULLY INTEGRATED DISHWASHER



PRODUCT CODE

Di491

DIMENSIONS

w:450mm

PERFORMANCE

e Energy class A+++
Wash Class A
Drying performance A
Max. noise level 42dB
Annual energy consumption 188kWh/yr
Annual water consumption 2240 Litres
Water consumption [economy] 8 Litres
Energy consumption per cycle [economy] 0.66kWh

FINISH AVAILABLE

Stainless steel control panel with LED display

PROGRAMMES

8 Programmes
Auto/45-55°C
Normal/55°C
Intensive/60°C
Economy/45°C
90min/65°C
Glass/40°C
Rapid/45°C
Pre-wash

FUNCTIONS

- Delayed timer 1-24hr
- Alternative wash
- Extra drying
- Extra wash
- Power wash
- Energy saving mode

FEATURES

- 10 Place settings
- Max. plate diameter 30cm
- Stainless steel inner door and interior
- Internal light
- Top cutlery tray
- Titanium grey baskets
- Cold water connection
- Hidden heating element
- Easy adjustable upper basket
- Easy clean filter system
- Electronic salt and rinse aid warning light
- 6 Level water softening system
- Water overflow protection system
- Aquastop

INSTALLATION

- Diagram [p.247]
- Voltage 220-240V
- Rated load 2.1kW
- Fuse rating 10A

FULLY INTEGRATED DISHWASHER



PRODUCT CODE

Di481

DIMENSIONS

w:450mm

PERFORMANCE

e Energy class A++
Wash Class A
Drying performance A
Max. noise level 49dB
Annual energy consumption 197kWh/yr
Energy consumption per cycle 0.74kWh/cycle
Annual water consumption 2520 Litres
Water consumption [economy] 9 Litres

FINISH AVAILABLE

Black gloss door top control panel

PROGRAMMES

5 Programmes
Normal/55°C
Intensive/65°C
Economy/50°C
1 Hour express/60°C
Rapid/40°C

FUNCTIONS

- Delayed timer 3, 6 or 9hrs

FEATURES

- 9 Place settings
- Max. plate diameter 30cm
- Stainless steel inner door and interior
- Titanium grey baskets
- Salt and rinse aid warning light
- Cold water connection
- Hidden heating element
- Adjustable upper basket
- Easy clean filter system
- 6 Level water softening system
- Water overflow protection system

INSTALLATION

- Diagram [p.247]
- Voltage 230V
- Rated load 1.93kW
- Fuse rating 13A



Laundry

A reliable washing machine and tumble dryer is an absolute must for any family. We've taken things further, with a range that's packed with features, good looks and performance.



WASHING MACHINES

Choose from a selection of integrated machines that tuck neatly away. Whichever you opt for, you can be sure it will do the job in style. All our machines use the most advanced technology to make laundry day just that bit easier.

DIGITAL DISPLAY

Included on all models. Shows the programme phase, spin speed and any extra functions selected.



EXTRA LARGE DOORS

Makes loading and unloading much easier.



MY CYCLE

Create and easily access your most frequently used programme.

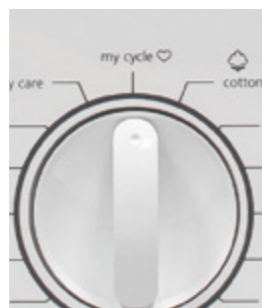

SUPERIOR FABRIC PROTECTION

The new Caple Diamond+ Drum offers superior fabric protection, allowing clothes to gently glide across the surface preventing rips, laddering and pilling.



ELECTRONIC WASHING MACHINE



PRODUCT CODE
WMI3005

DIMENSIONS
w:600mm

PERFORMANCE
Energy class A+++
Wash Class A
Spin efficiency B
1400rpm max. spin speed
11000 Litre annual water consumption
Est. annual energy consumption 196kWh/yr
Max. noise level wash 57dB, spin 76dB

FINISH AVAILABLE
White

PROGRAMMES
16 Programmes
Cotton Intensive
Cotton 60°C
Cotton 40°C
Cotton 20°C
15min Quick wash
Eco
Rinse
Baby care
Sports
Synthetic
Mixed
Delicate
Wool
Drain

Spin
My Cycle

7 Options
Delay timer [up to 24hrs]
Pause
Intense
Spin speed selection
Temperature selection
Pre wash
Extra rinse

FEATURES
- Cold fill
- 15 minute fast wash
- Digital display
- 310mm extra large door
- Door safety lock
- Programme time remaining
- Variable spin speed
- Stainless steel Diamond+ drum
- Anti-overflow protection
- Foam control

CAPACITY
- 8kg washing capacity

INSTALLATION
- Diagram [p.247]
- Rated load 2.0kW
- Fuse rating 10A

ELECTRONIC WASHING MACHINE



PRODUCT CODE
WMI3000

DIMENSIONS
w:600mm

PERFORMANCE
Energy class A++
Wash Class A
Spin efficiency B
1200rpm max. spin speed
9240 Litre annual water consumption
Est. annual energy consumption 173kWh/yr
Max. noise level wash 57dB, spin 74dB

FINISH AVAILABLE
White

PROGRAMMES
16 Programmes
Cotton Intensive
Cotton 60°C
Cotton 40°C
Cotton 20°C
15min Quick wash
Eco
Rinse
Baby care
Sports
Synthetic
Mixed
Delicate
Wool
Drain

Spin
My Cycle

7 Options
Delay timer [up to 24hrs]
Pause
Intense
Spin selection
Temperature selection
Pre wash
Extra rinse

FEATURES
- Cold fill
- 15mins fast wash
- Digital display
- 300mm extra large door
- Door safety lock
- Programme time remaining
- Variable spin speed
- Stainless steel Diamond+ drum
- Anti-overflow protection
- Foam control

CAPACITY
- 6kg washing capacity

INSTALLATION
- Diagram [p.247]
- Rated load 2.0kW
- Fuse rating 10A

WASHER DRYER

Our integrated washer dryer offers multiple programmes that are easy to operate, meeting all your laundry needs with minimal fuss.

ELECTRONIC CONTROLS

Simple controls mean you can change between options at the click of a button.

DOOR SAFETY LOCK

Our machine operates at high temperatures during mid-cycle. The door will remain locked until the clothes cool 53°C.

STAIN REDUCTION

Uses advanced technology to maximise cleaning action, keeping your whites looking fresher for longer.



ELECTRONIC CONDENSER WASHER DRYER



PRODUCT CODE

WDi3300

DIMENSIONS

↔ w:600mm

PERFORMANCE

e Energy class A
Wash Class A
Spin efficiency A
1400rpm max. spin speed
152 Litre water consumption [wash and dry cycle]
Est. energy to wash and dry full load 5.44kWh
Max. noise level wash 54dB, spin 78dB, dry 62dB

FINISH AVAILABLE

White

PROGRAMMES

16 Programmes

Fast wash 15mins
Cotton
Cotton Eco
Synthetic
Wool
Delicate
Baby care
Sports
Colours
Jeans
1hour wash & dry
Mixed
Drain
Spin

Dry
Personalised

5 Options

Delay timer [24hrs]
Pause
Spin selection
Temperature selection
Damp dry

FEATURES

- Final cool down tumble
- Cold fill
- 15 Minute fast wash
- White LED display
- Electronic controls
- 310mm extra large door
- Door safety lock
- Programme time remaining
- Variable spin speed
- Automatic variable load
- Stainless steel drum
- Anti-overflow protection
- Pause function
- 1.5m power cord

CAPACITY

- 8kg washing, 6kg drying

INSTALLATION

- Diagram [p.247]
- Rated load 1.9kW
- Fuse rating 10A



TUMBLE DRYERS

We want your lives to be easier. Caple's intelligent tumble dryers make sure you always have a pile of soft, freshly-laundered garments ready when you need them.



There are six levels of dryness, so you can choose finishes ranging from ready-to-wear and easy-to-iron. With generous 6kg or 7kg capacities, these are essential machines for busy families.

Our fully integrated tumble dryers offer two heat settings and a venting system for the best possible performance. The TDi111 also has sensors in the drum that constantly check moisture levels, so the machine only stops when clothes are completely dry. Other handy features include a reverse tumble action and an easy-access fluff filter.

FULLY INTEGRATED SENSOR VENTED TUMBLE DRYER



PRODUCT CODE

TDi111

DIMENSIONS

↔ w:600mm

PERFORMANCE

e Energy class C
 Est. annual energy consumption 519kWh/yr
 Average energy by cycle 4.39kWh
 Max. noise level 62dB

FINISH AVAILABLE

White

OPTIONS

6 Sensor drying levels

- Extra dry
- Cupboard dry
- Mid dry
- Extra iron dry
- Iron dry
- Damp dry

FEATURES

- Vented drying
- 2 Heat settings
- 30 minute timed drying with heat
- 30 minute refresh
- Reverse tumble action
- Final cool down tumble
- Easy access fluff filter
- Rear vented only
- Integral extendable 2.4m hose and wall outlet
- Reversible appliance and furniture door
- Adjustable legs

CAPACITY

- 7kg drying capacity

INSTALLATION

- Diagram [p.247]
- Electrical connection
- Rated load 2.7kW
- Fuse rating 13A

FULLY INTEGRATED VENTED TUMBLE DRYER



PRODUCT CODE

TDi101

DIMENSIONS

↔ w:600mm

PERFORMANCE

e Energy class C
 Est. annual energy consumption 459kWh/yr
 Max. noise level 62dB

FINISH AVAILABLE

White

FEATURES

- Vented drying
- 2 Heat settings
- Reverse tumble action
- Final cool down tumble
- Easy access fluff filter
- Rear vented only
- Integral extendable 2.4m hose and wall outlet
- Reversible appliance and furniture door
- Adjustable legs

CAPACITY

- 6kg drying capacity

INSTALLATION

- Diagram [p.247]
- Electrical connection
- Rated load 2.7kW
- Fuse rating 13A



PLINTH HEATERS



PRODUCT CODE

PH500H

DIMENSIONS

- Grille: 495 x 100mm
- Heater: 320 x 400mm [including pipe work]
- Plinth cut out: 360 x 96mm

FUNCTIONS

- 500mm hydronic plinth heater [central heating]
- Stainless steel grille
- 2 speed fan
- Summer setting [fan circulates air round the room]
- Up to 24% more efficient than standard radiators
- Auto switch on
- Easy install
- Low noise

CONNECTIONS

- Fuse rating: 3amp
- Voltage: 220-240 / 50hz
- Heat output: 3057 - 3979 Btu [0.9 - 1.17kW]
- Maximum working pressure: 8bar [1Mpa]

OPTIONAL EXTRAS

- White plinth grille available [PHHGRILL/WH]

Visit caple.co.uk for full range

PRODUCT CODE

PH501E

DIMENSIONS

- Grille: 495 x 100mm
- Heater: 320 x 200mm
- Plinth cut out: 360 x 96mm

FUNCTIONS

- 500mm electric plinth heater
- Stainless steel grille
- 2 speed fan
- Easy install
- Low noise

FEATURES

- Wall thermostat included

CONNECTIONS

- Fuse rating: 10amp
- Voltage: 220-240 / 50hz
- Heat output: 940 -1990w

OPTIONAL EXTRAS

- White plinth grille available [PHHGRILL/WH]

Visit caple.co.uk for full range

Features

WHITE GRILLES

Optional extra plinth grille finished in white.

- PHHGRILL/WH
- PHHGRILL/WH



FOOD WASTE DISPOSAL

A waste disposer hidden away under the sink can help you recycle your food scraps and leftovers like potato peelings, chicken bones, egg shells and tea bags. It's clean, it's green and it leaves less to clutter up your bin. It also reduces any decomposing food odours.

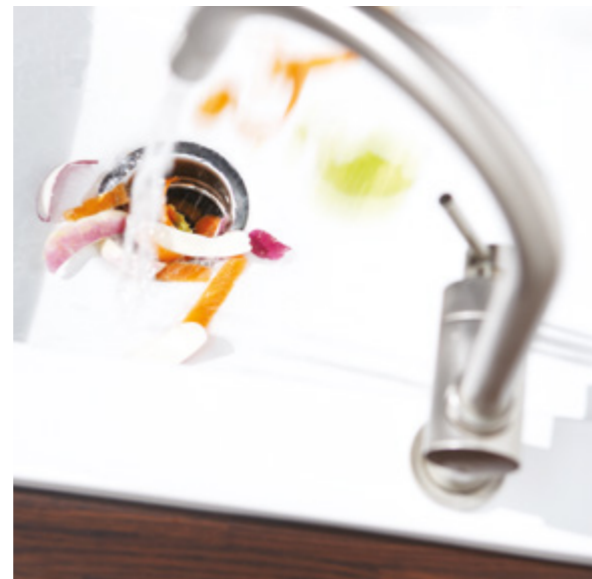

It couldn't be easier or more convenient to use. Simply turn on the cold tap and the disposer then empty everything into the sink. The disposer grinds the food waste into fine particles and flushes the waste away down the drain.

Since more than 25% of household refuse is food, that means much less rubbish to take away and clog up our landfill sites. It also means a reduction in the amount of greenhouse gases emitted. Waste from your disposer can actually be recycled into a soil conditioner once it reaches the water treatment plant, so you will be making a positive contribution to your environment.

FOOD WASTE DISPOSAL UNITS



PRODUCT CODE

WDU050

DIMENSIONS

w:175mm
 d:175mm
 h:372mm

FEATURES

- 0.5hp waste disposal unit
- Continuous feed
- High speed magnet motor
- Overload protection
- Corrosion resistant 3 stage grinding system
- Easy mount installation
- Sound insulation
- 2 Year guarantee
- Suitable for air switch [WDAIR - see opposite]

OPTIONAL EXTRAS

- Air switch [WDAIR] for WDU050 only
- Basket strainer waste decorative cover [CWC2]
Visit cople.co.uk for full range

PRODUCT CODE

WDU075

DIMENSIONS

w:216mm
 d:216mm
 h:400mm

FEATURES

- 0.75hp waste disposal unit
- Continuous feed
- High speed magnet motor
- Overload protection
- Corrosion resistant 3 stage grinding system
- Easy mount installation
- Sound insulation
- 2 Year guarantee
- Air switch [WDAIR] included

OPTIONAL EXTRAS

- Basket strainer waste decorative cover [CWC2]
Visit cople.co.uk for full range

PRODUCT CODE

WDU100

DIMENSIONS

w:216mm
 d:216mm
 h:437mm

FEATURES

- 1.0hp waste disposal unit
- Continuous feed
- High speed magnet motor
- Overload protection
- Corrosion resistant 3 stage grinding system
- Easy mount installation
- Sound insulation
- 3 Year guarantee
- Air switch [WDAIR] included

OPTIONAL EXTRAS

- Basket strainer waste decorative cover [CWC2]
Visit cople.co.uk for full range

Features

WDAIR

The chrome air switch is an optional extra with the WDU050 and comes as standard with the WDU075 and WDU100.



WDAIR



CWC2

INSTALLATION DIAGRAMS

SINGLE OVENS

C2901

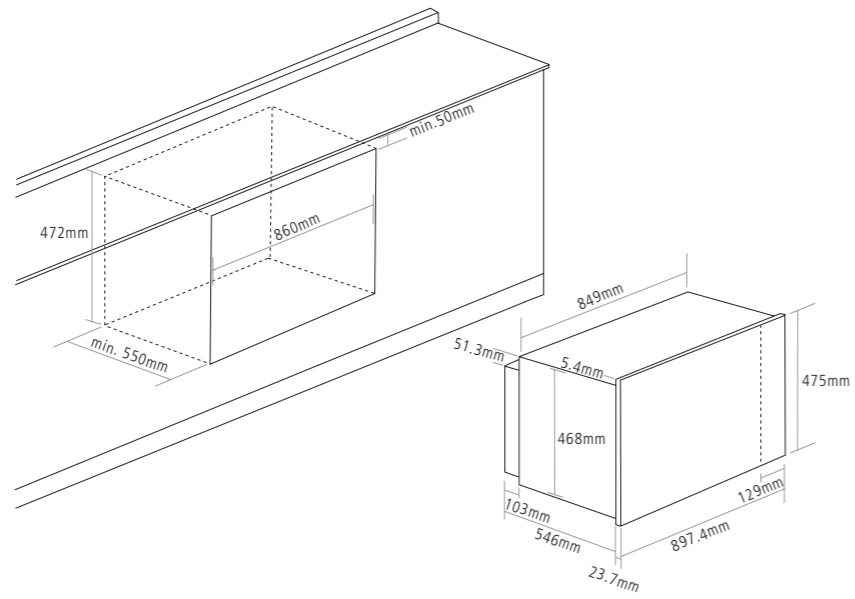

C2401 / C2401GM / C2105 / C2105GM / C2101 / C2362

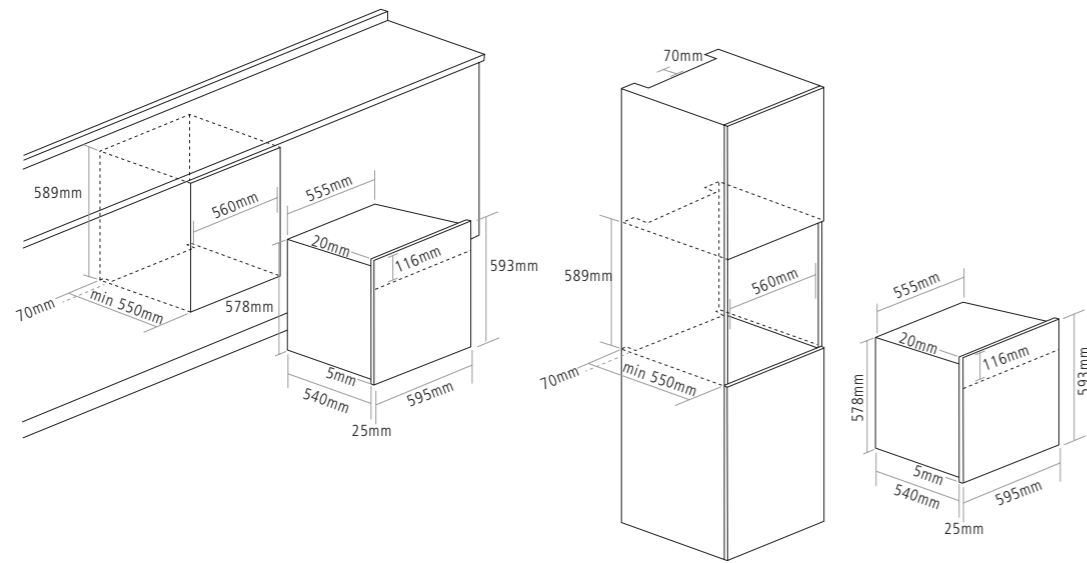

SINGLE OVENS

C2231 / C2234 / C2234BK / C2237 / C2239

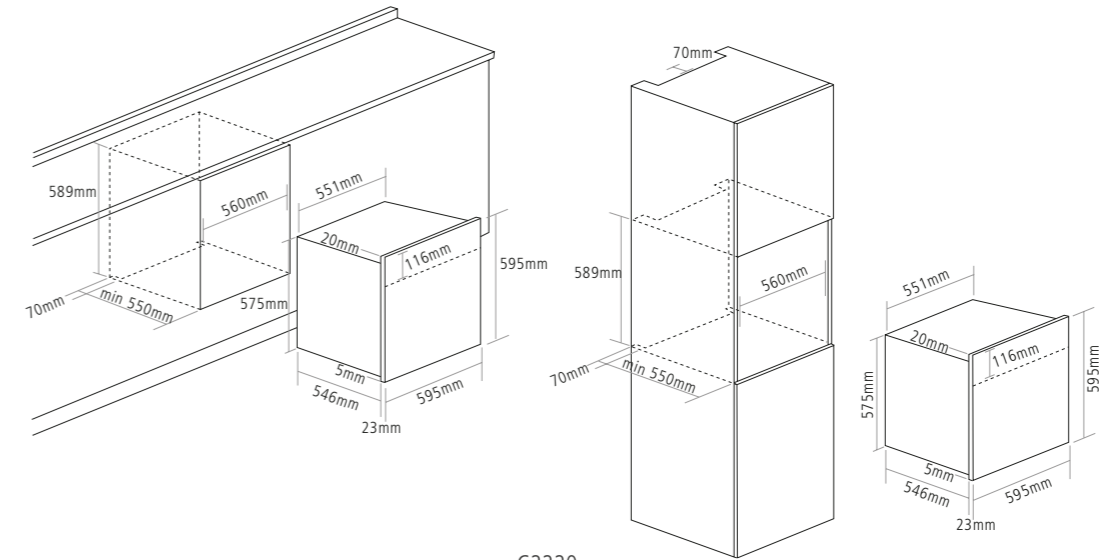

C2220

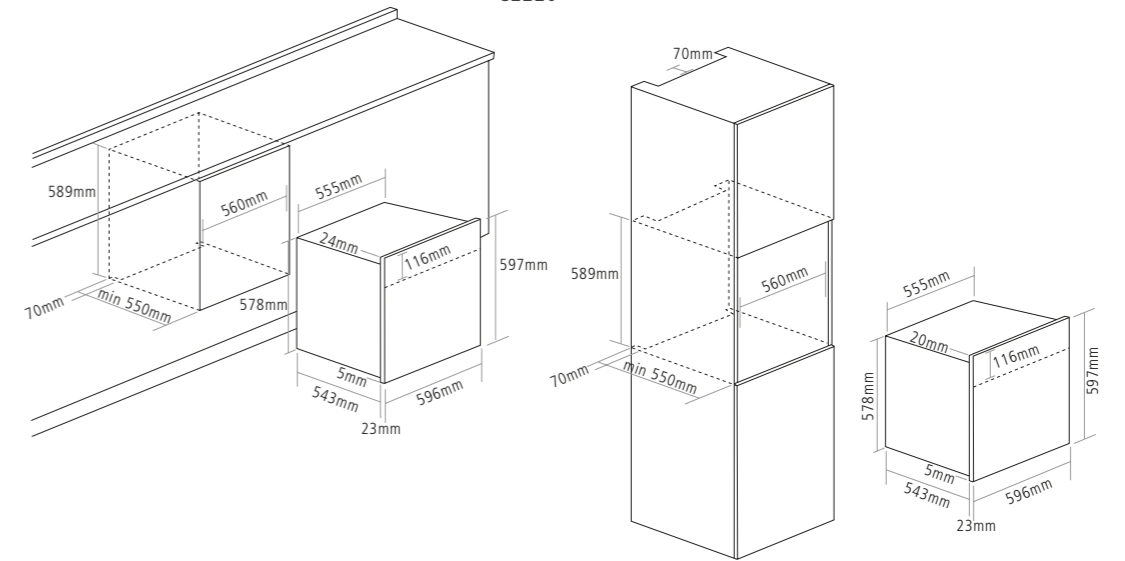

DOUBLE OVENS

C3371 / C3248 / C3246

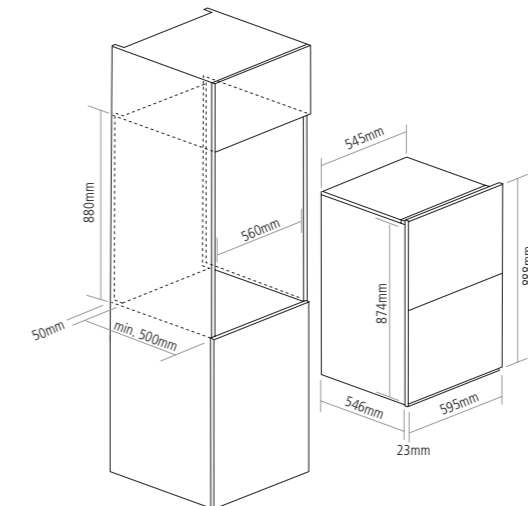

We recommend that when installing a stack or quad of products, a pair of our installation brackets [OVEN/BRACKETS2] are purchased to support the upper product ensuring a seamless fit for each appliance when one is on top of the other.

We recommend that when installing a stack or quad of products, a pair of our installation brackets [OVEN/BRACKETS2] are purchased to support the upper product ensuring a seamless fit for each appliance when one is on top of the other.



BUILT-UNDER DOUBLE OVEN

C4246

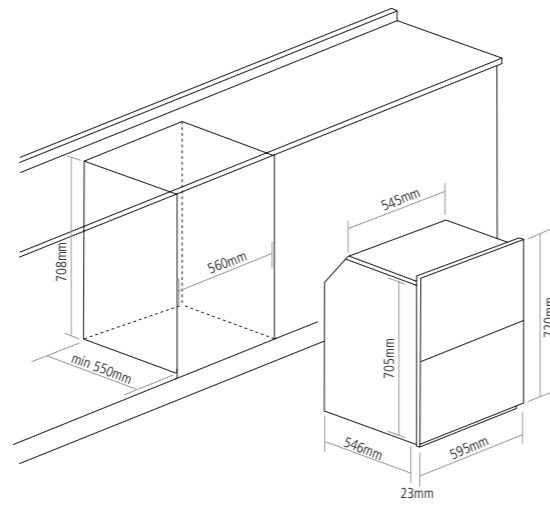

MICROWAVES

CM130

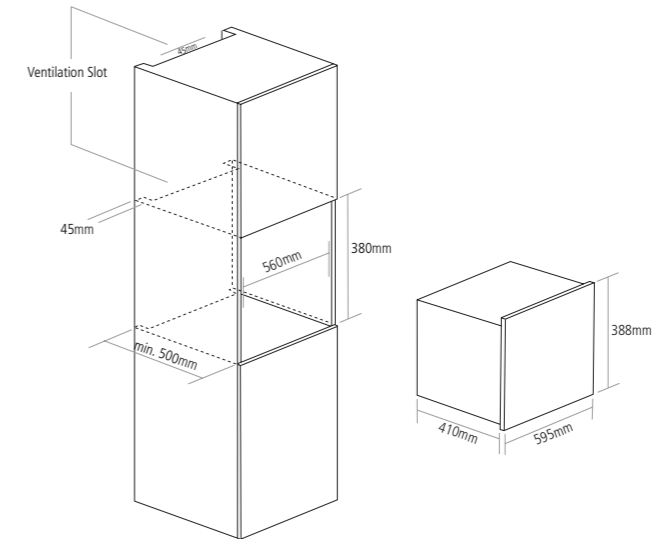

STEAM OVENS

SO110 / SO110GM

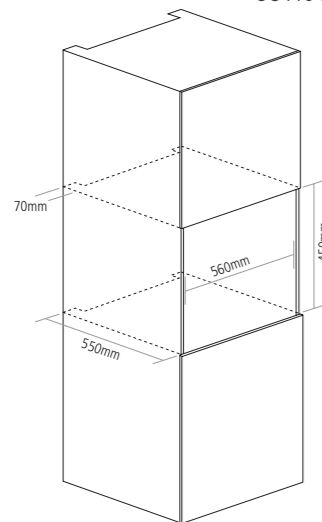

MICROWAVES

CM110 / CM110GM / CM108

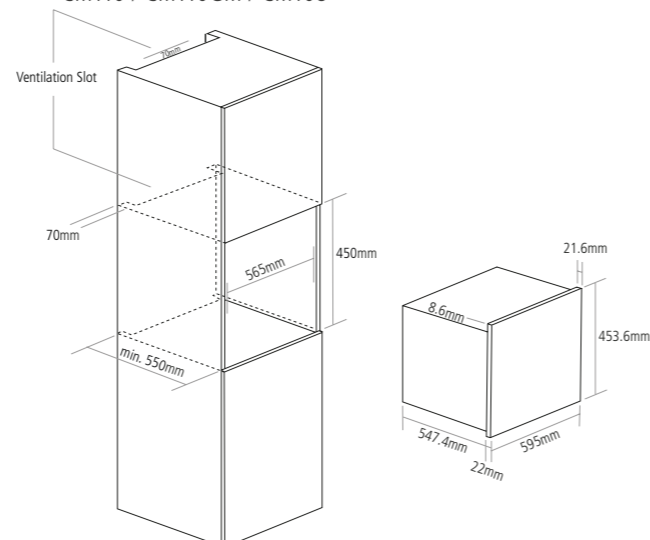

CM126

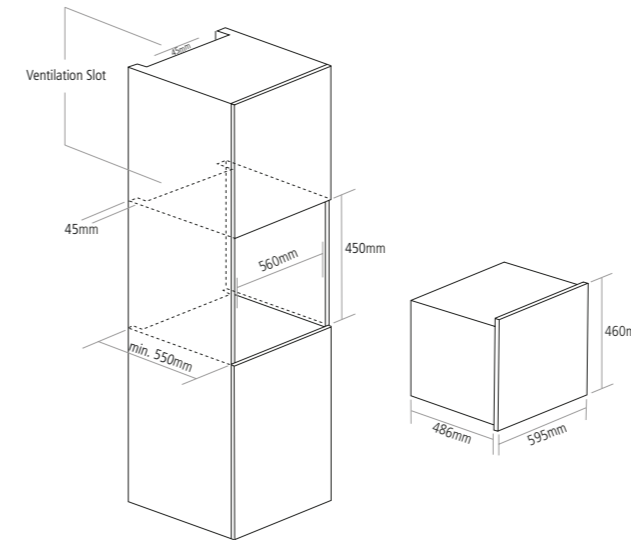

CM120

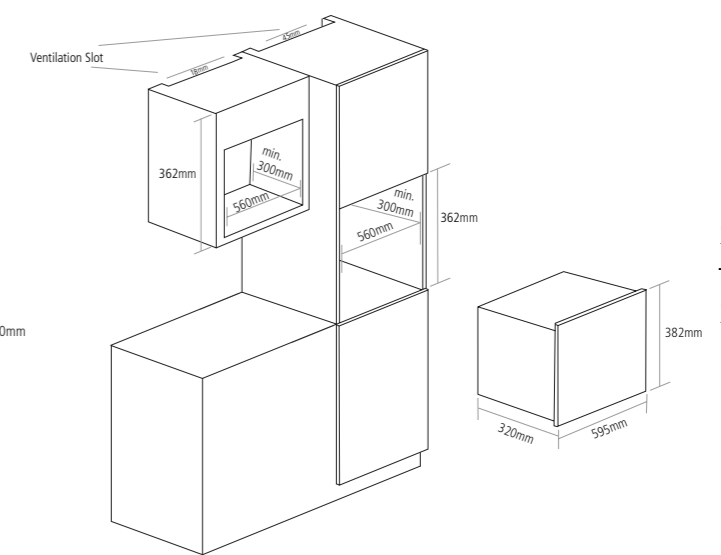

CM108SS / CM108BK

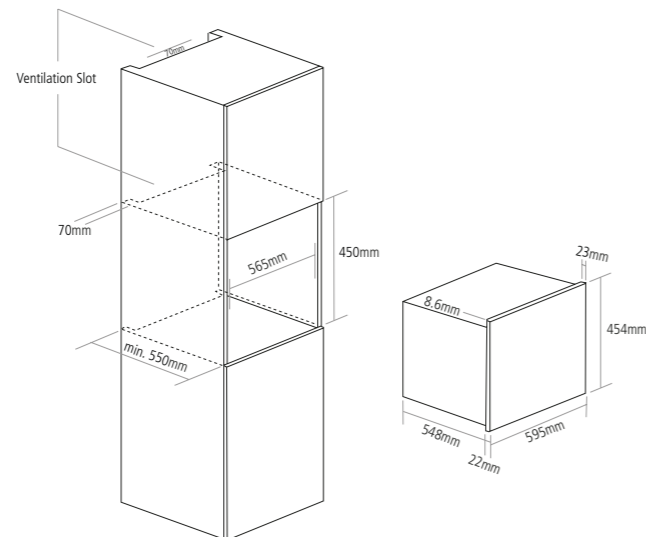

CM123 / CM123BK

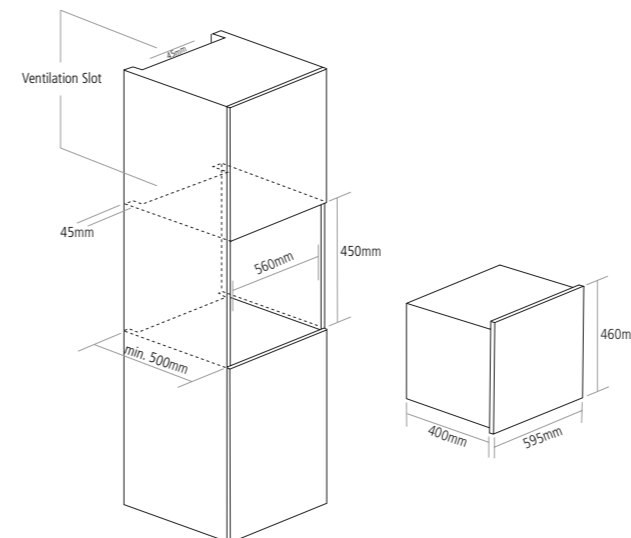

COFFEE MACHINES

CM465

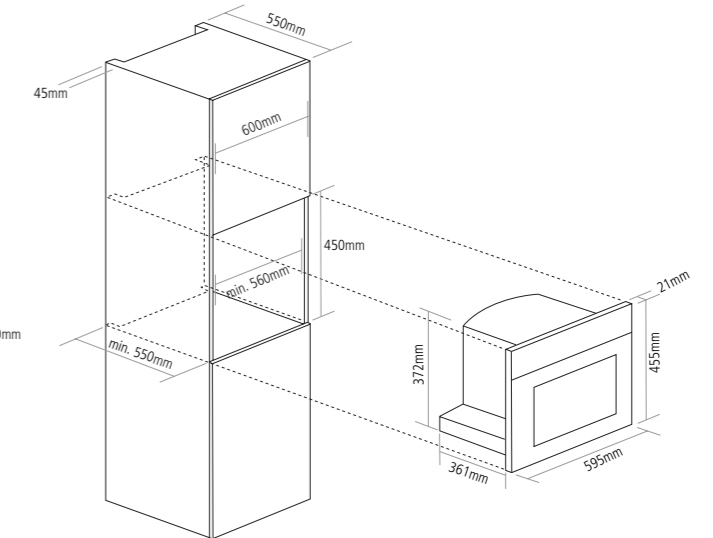

We recommend that when installing a stack or quad of products, a pair of our installation brackets [OVEN/BRACKETS2] are purchased to support the upper product ensuring a seamless fit for each appliance when one is on top of the other.

We recommend that when installing a stack or quad of products, a pair of our installation brackets [OVEN/BRACKETS2] are purchased to support the upper product ensuring a seamless fit for each appliance when one is on top of the other.



WARMING DRAWERS

WD140BK / WD140GM / WD140CLSS / WD140CLBK

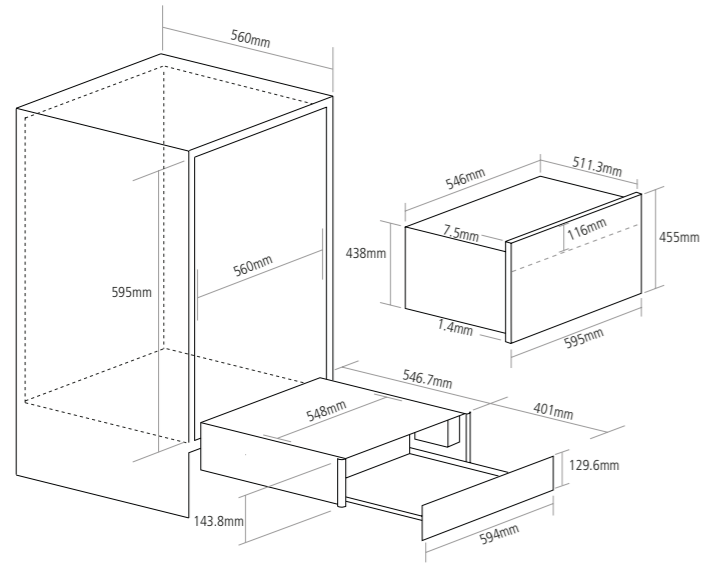

WD290BK

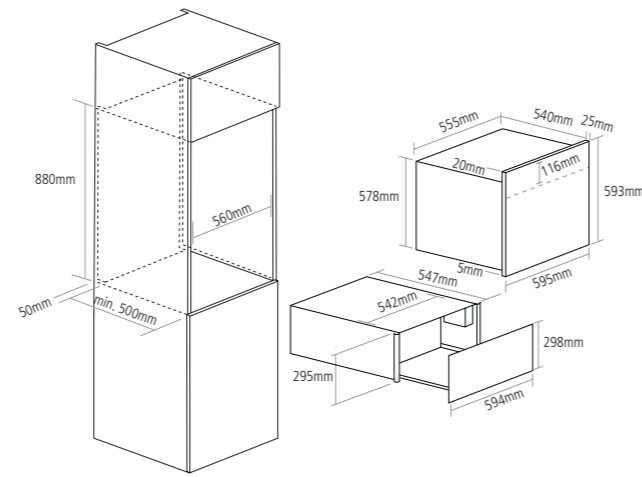

STORAGE DRAWER

SD140BK

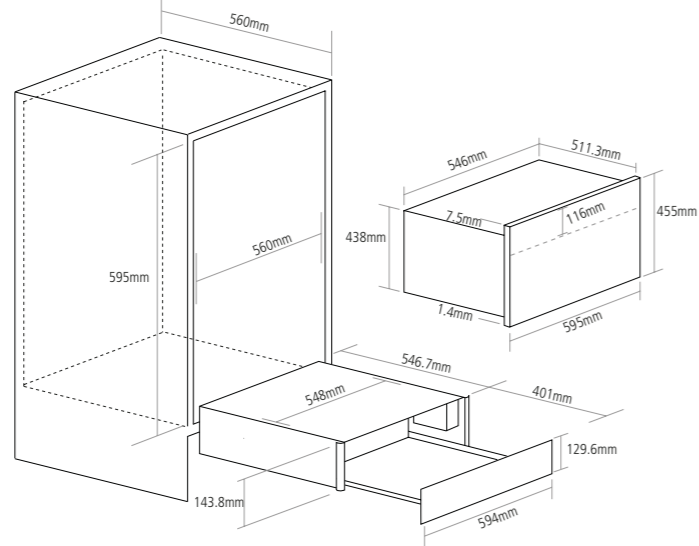

INDUCTION HOBS

C970i

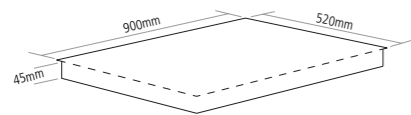

C876i

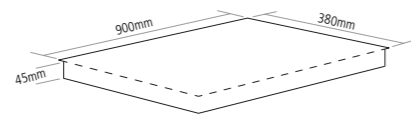

C901i

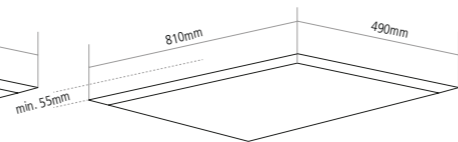
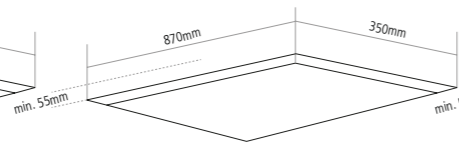
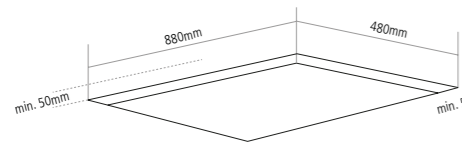
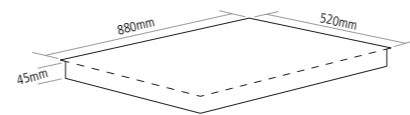

INDUCTION HOBS

C867i

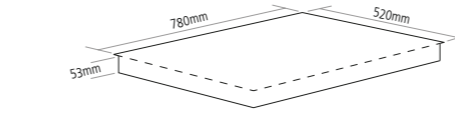

C857i

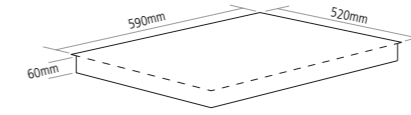

C864i

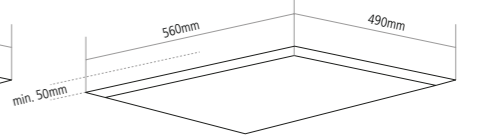
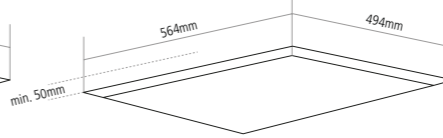
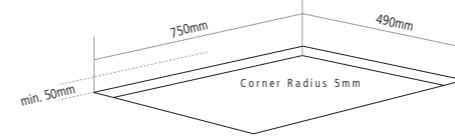
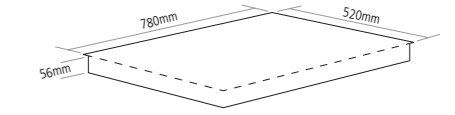

C846i

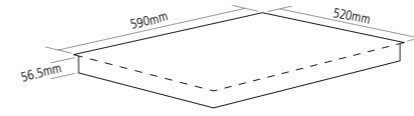

C843i

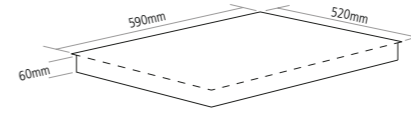

C840i

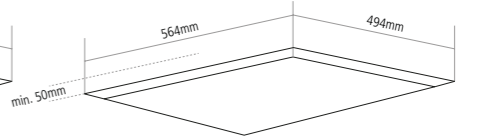
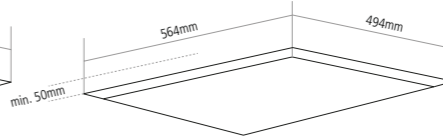
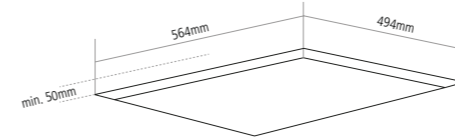
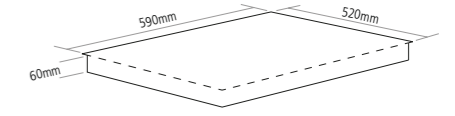

C950i

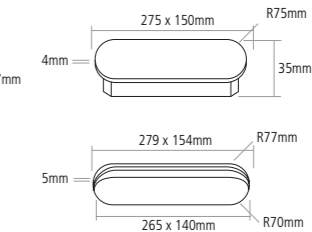
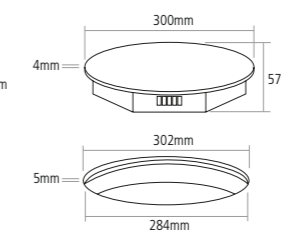
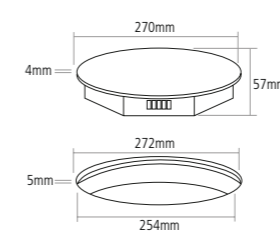

Induction hobs C950i - All 4 zones must be installed.

ELECTRIC HOBS

C815C / C808C

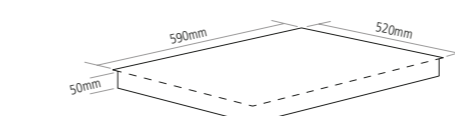

C605E

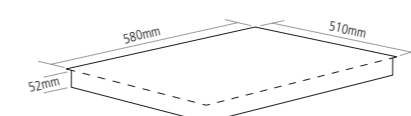

C824C

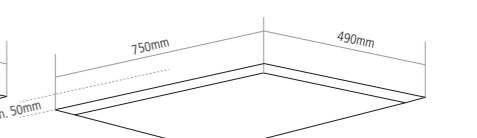
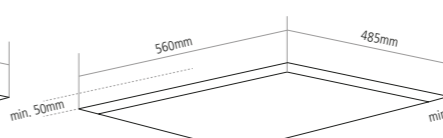
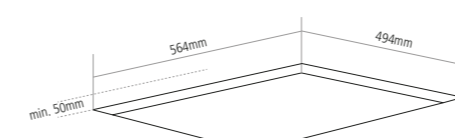
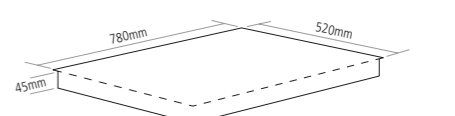

Induction hobs C950i, C901i, C970i and C867i:

A minimum gap of 20mm is required beneath the hob fans, and a 4mm gap must be left under the worktop at the front of the hob for ventilation.

We recommend that when installing a stack or quad of products, a pair of our installation brackets [OVEN/BRACKETS2] are purchased to support the upper product ensuring a seamless fit for each appliance when one is on top of the other.



GAS HOBS

C981G

C1081G

C871GBK

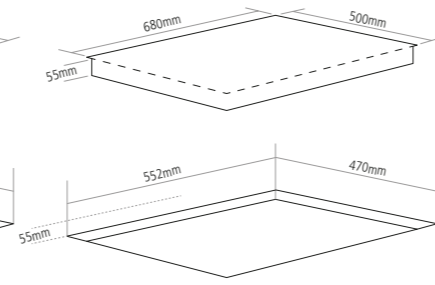
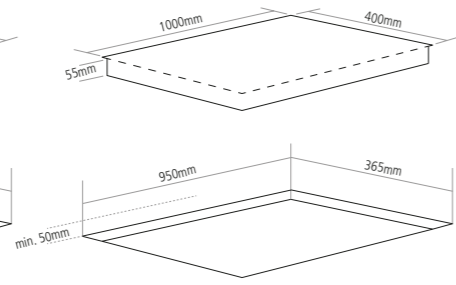
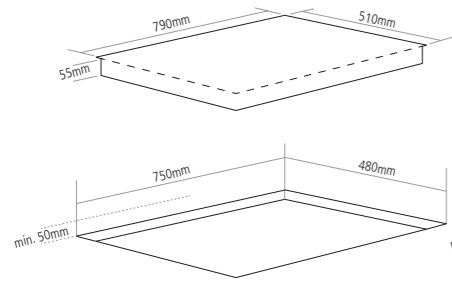

GAS HOBS

C972G

C772G

C1072G

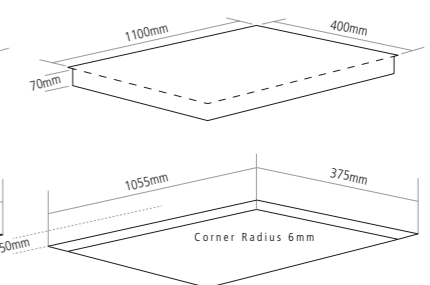
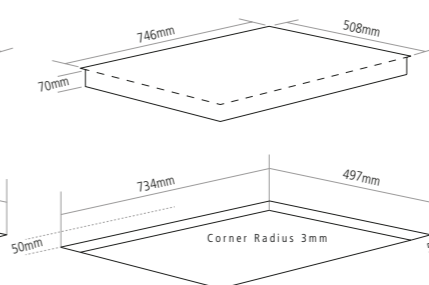
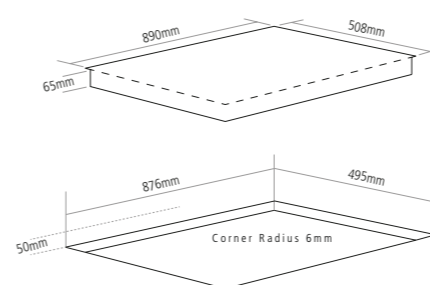

C887G

C789G

C787G

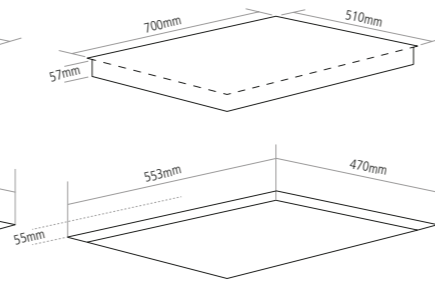
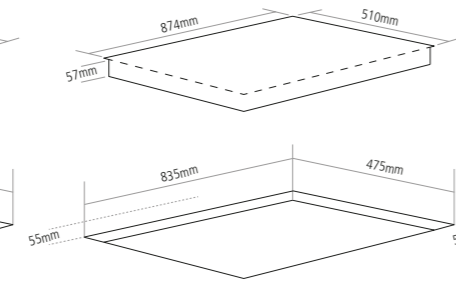
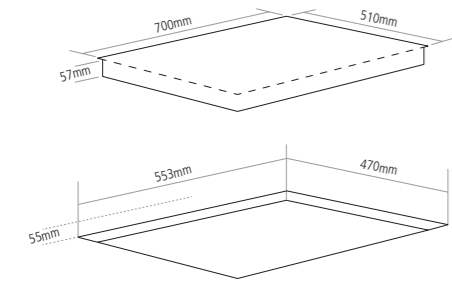

C873G

C866G

C848G

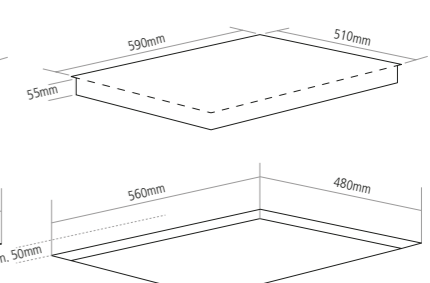
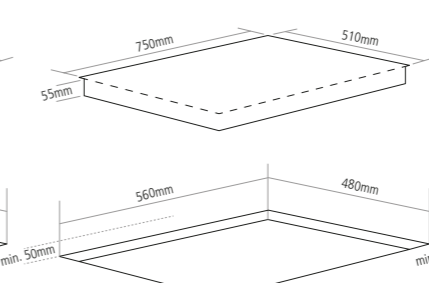
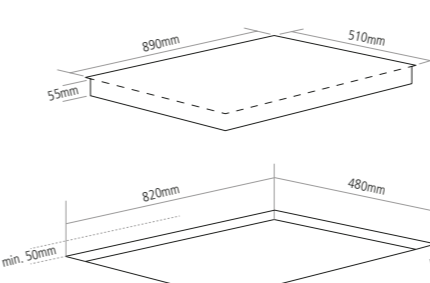

C786G

C769G

C759G

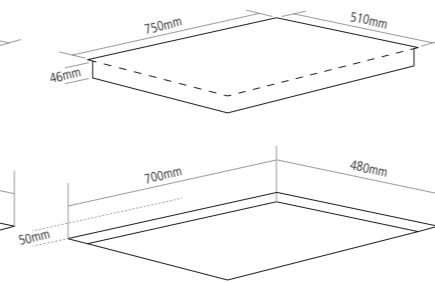
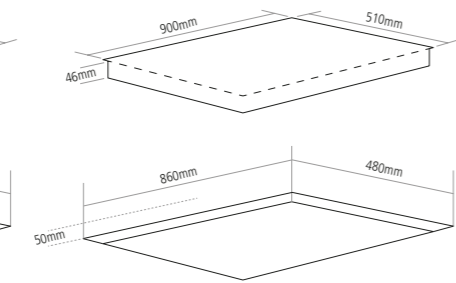
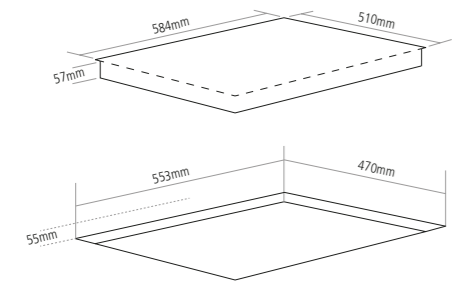

C774G

C767G

C749G

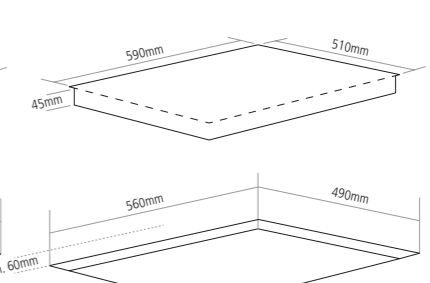
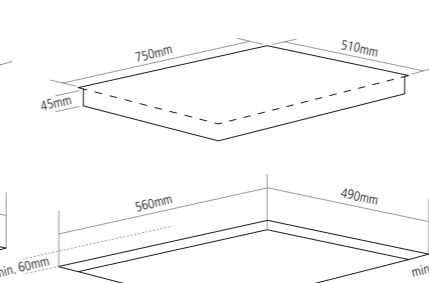
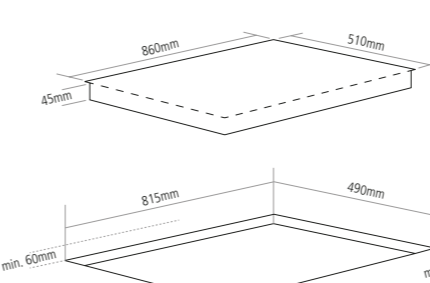

MODULAR HOBS

C739G

C744G

C944G

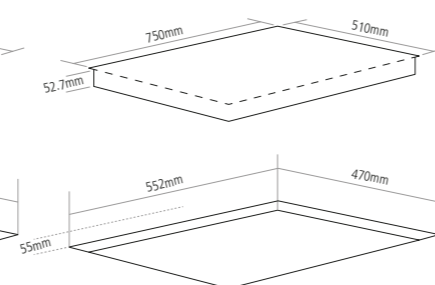
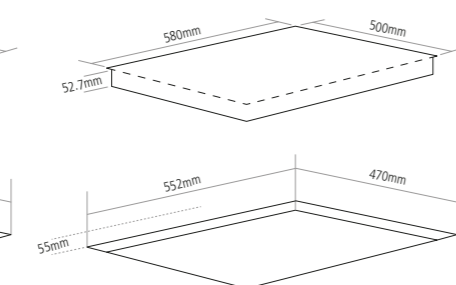
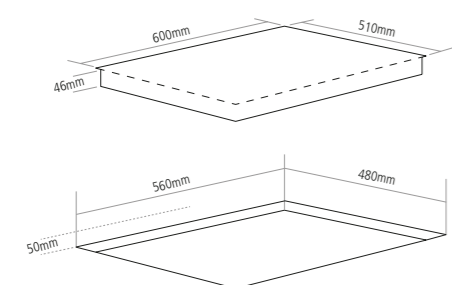

C706G

C995T / C993G

C996i

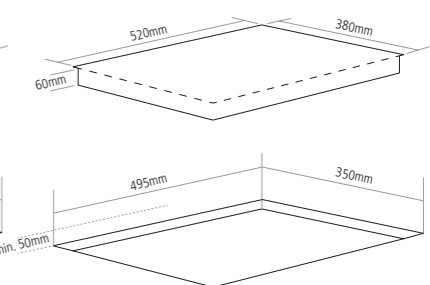
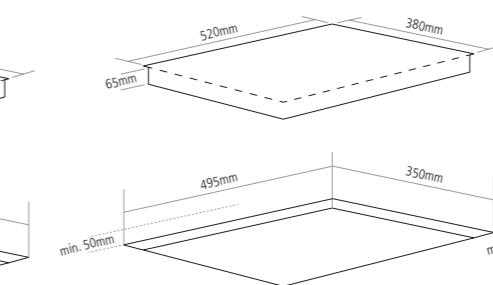
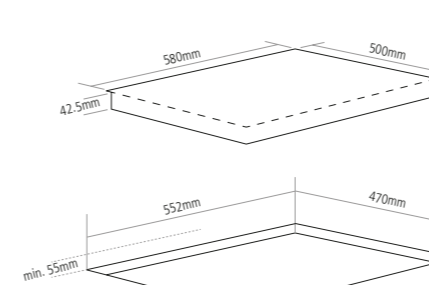

If installed without a gap in between, cut-out width = [no. of hobs - 1] x 288mm + 268mm



MODULAR HOBS

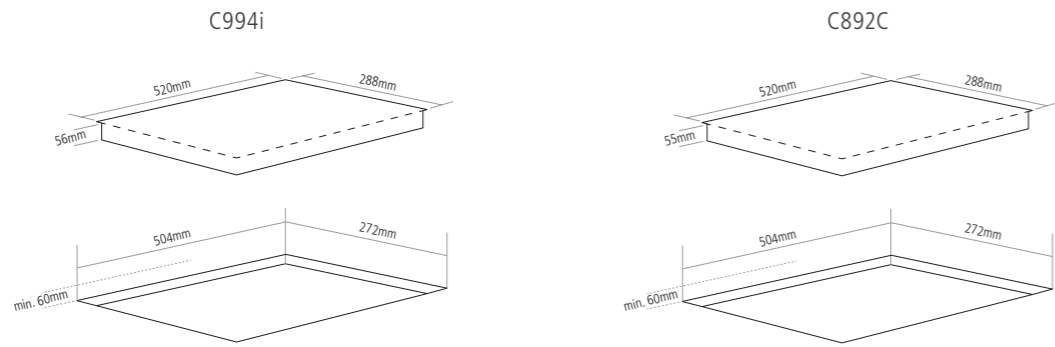

If installed without a gap in between, cut-out width = [no. of hobs - 1] x 288mm] + 268mm

INDUCTION DOWNDRAFT HOB

DD935BK

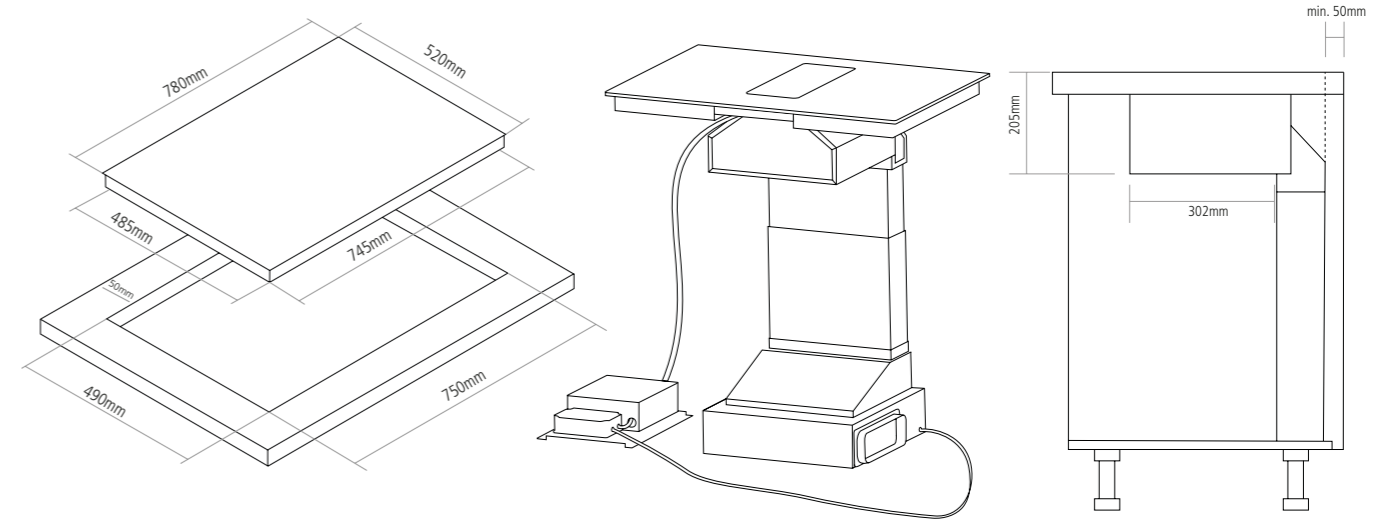

INDUCTION DOWNDRAFT HOB

DD940BK

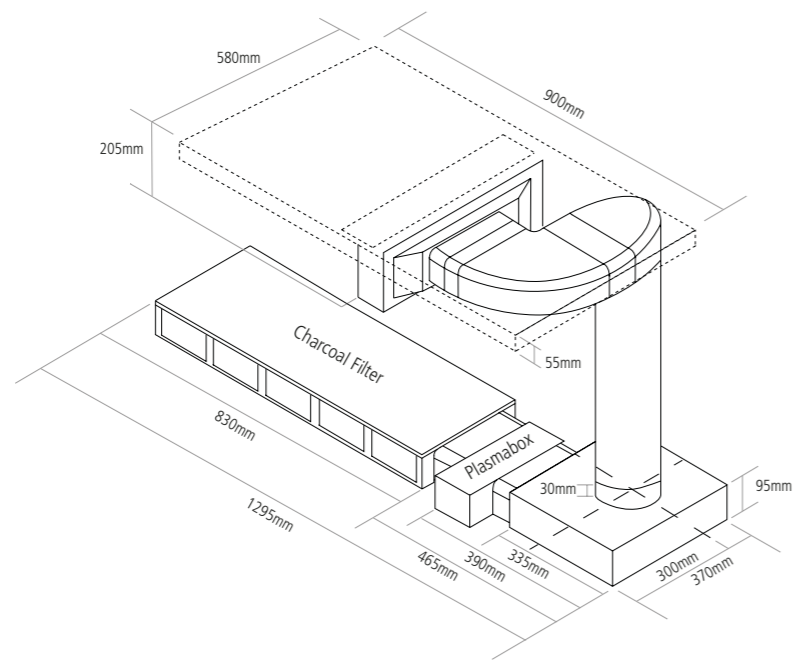

DOWNDRAFT EXTRACTORS

DD120BK

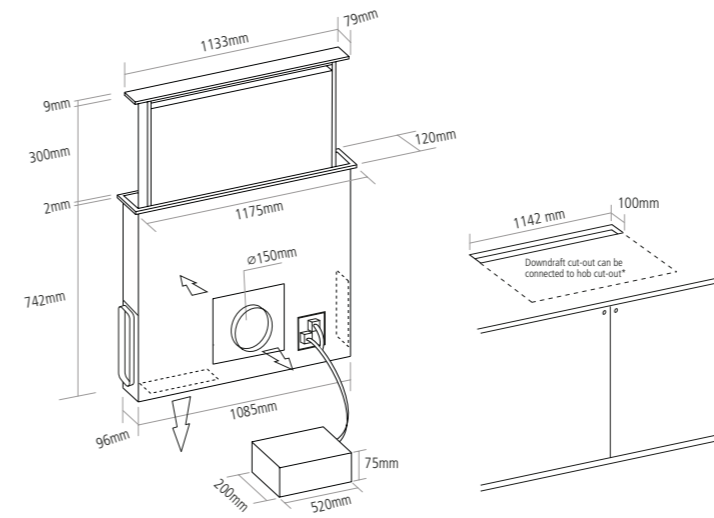

DD925CO

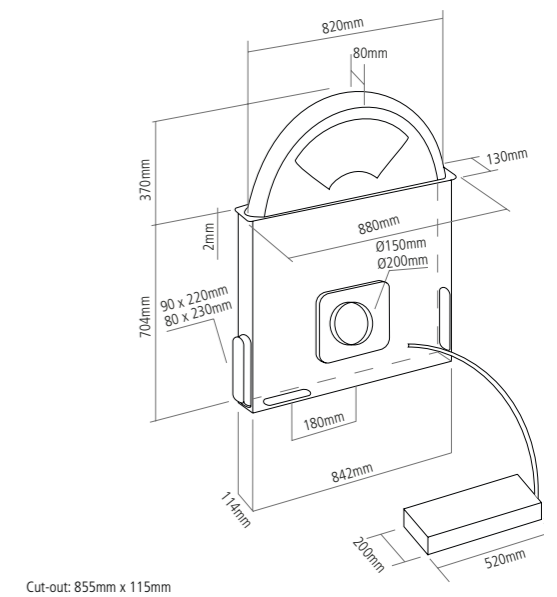

Cut-out: 855mm x 115mm

INSTALLATION

Example A

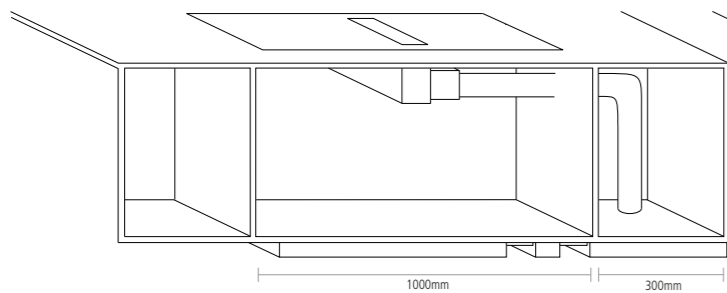

INSTALLATION

Example B

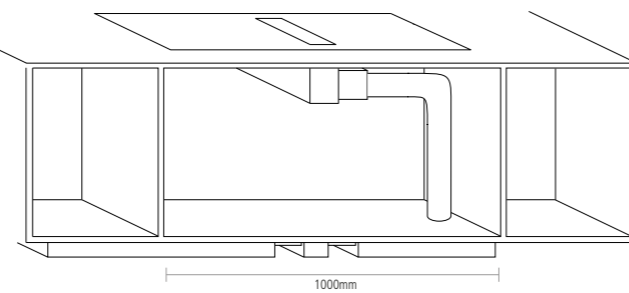

INSTALLATION MADE EASY

Minimum cabinet depth depends on orientation, hob type and worktop material. Cabinet base may need to be cut or routed to accommodate height of unit. If positioned behind a hob, minimum cabinet width for DD522/606 extractors is 600mm, for DD903/911/901 allow 900mm and for DD120BK 1200mm is required. If positioned alongside a hob, the cabinet may need to be reinforced to strengthen where the base has been modified.

The hood can be fitted right up to an electric hob [50mm gap required for gas hobs], but always ensure that the independent electronics box in the cupboard below is installed at least 650mm from the heat source.

The hood can be ducted from both sides enabling the downdraft to be positioned behind a hob and under-counter oven.

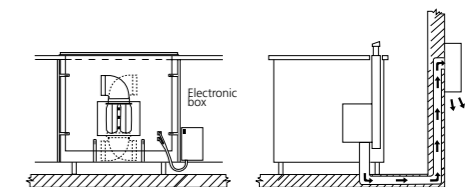



DOWNDRAFT EXTRACTORS

DD911SS / DD911WH / DD911BK

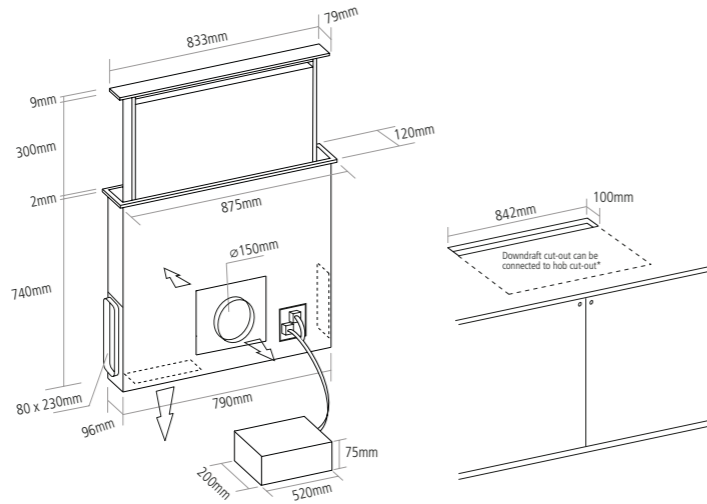

DD901BK

DD522BK

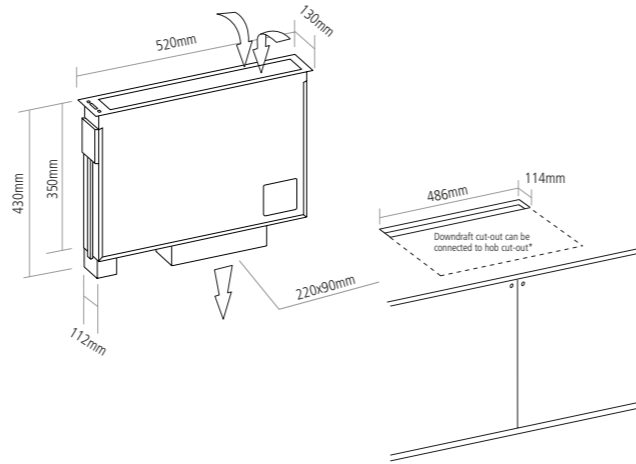
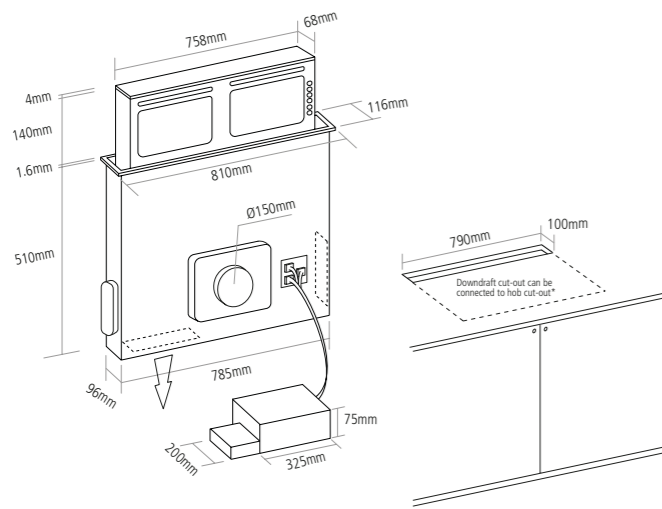

DD606SS / DD606BK

DD903BK

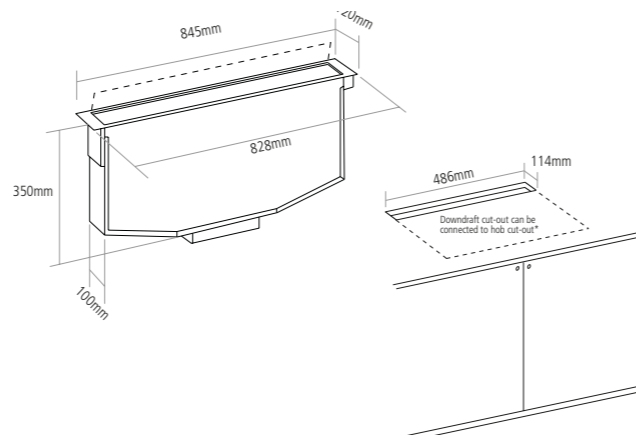
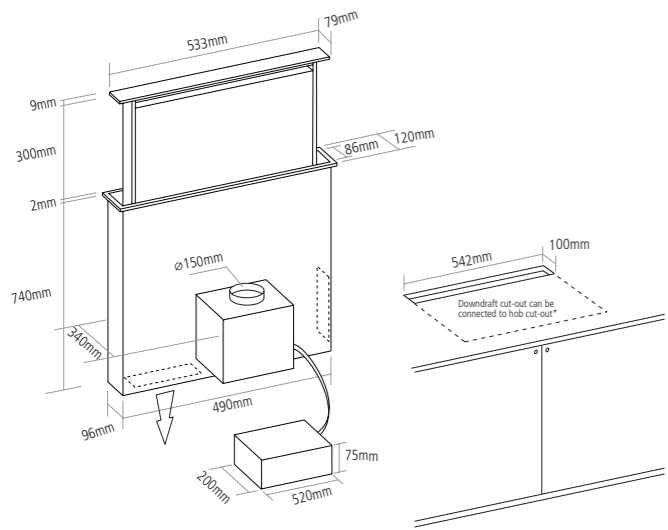

***FOR ELECTRIC HOBS ONLY. A 50MM GAP IS REQUIRED FOR GAS HOBS. SEE INSTALLATION EXPLAINED PG. 231**

CEILING HOODS

CE1000

CE1122

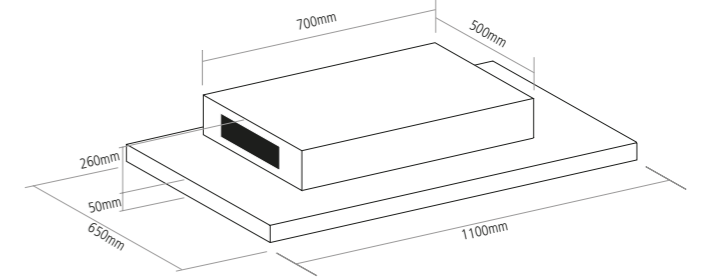
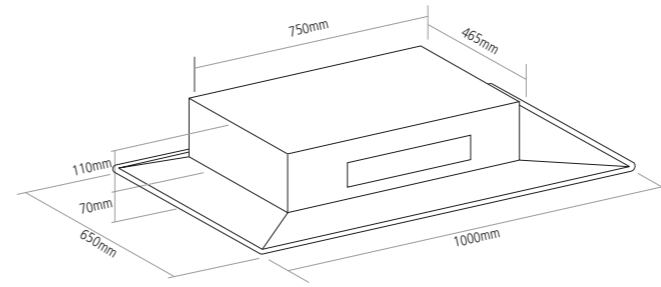

Minimum build in depth 215mm

CE920WH

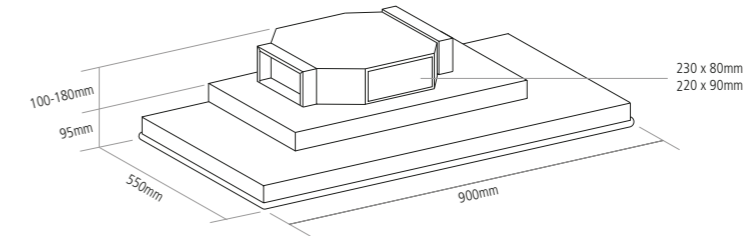

For installation into the ceiling a niche of 865mm by 515mm is required, with a minimum height of 200mm

CE1101

CE902SS / CE902WH

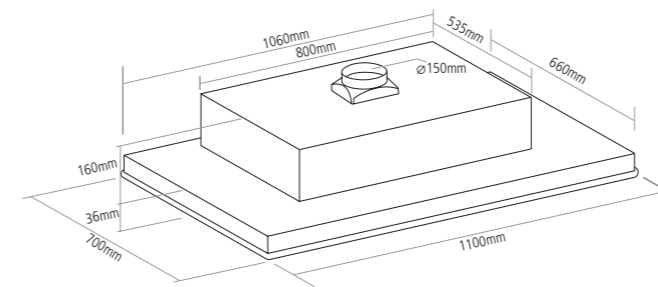

Minimum build in depth 270mm

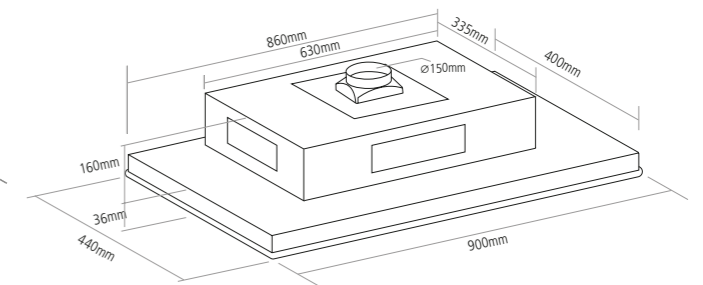

Minimum build in depth 270mm

EXTRACTION MOTORS

DDMEXT11

DDMEXT21

DDMEXT25

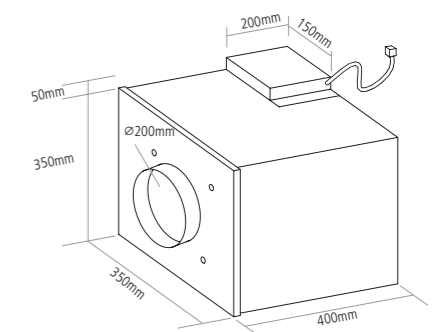
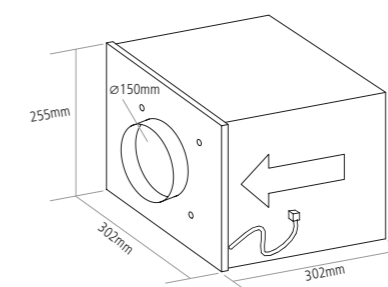
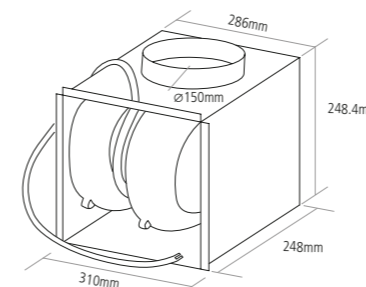



EXTRACTION MOTORS

DDMEXT28

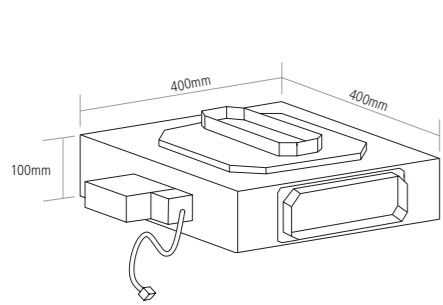

DDMEXT30

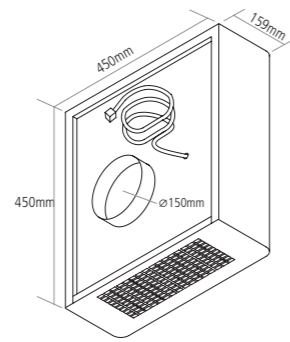

DDMEXT40

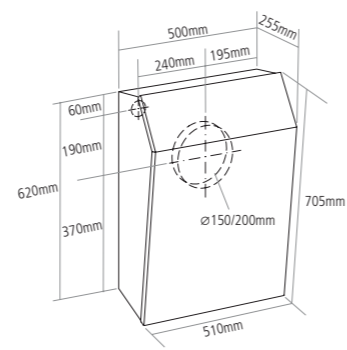

ISLAND HOODS

BXi911

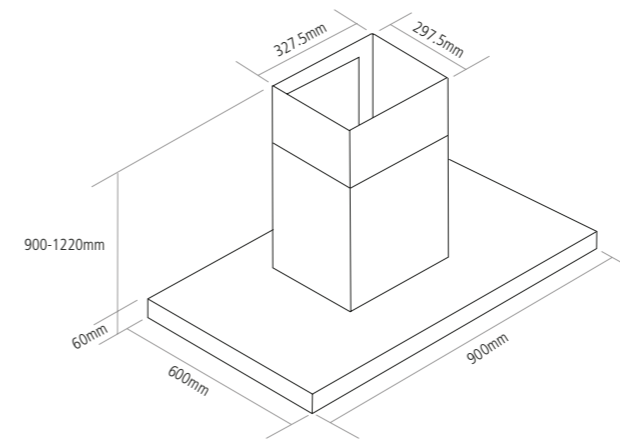

Zi922

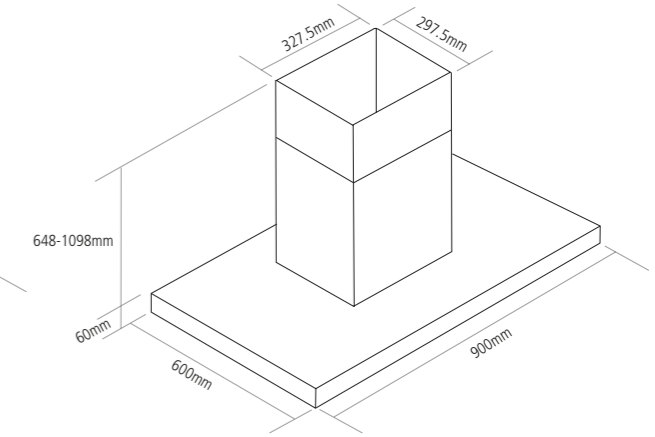

ISLAND HOODS

CR700 / CR700WH / CR700SL

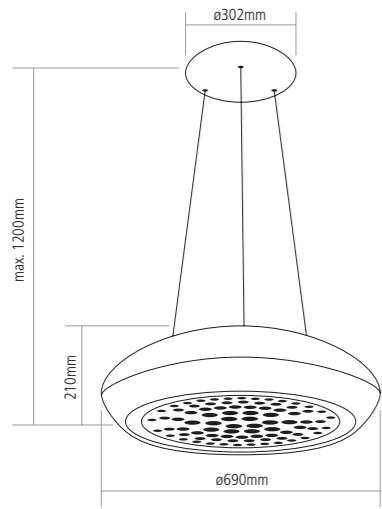

CR750CO / CR750WH / CR750SL

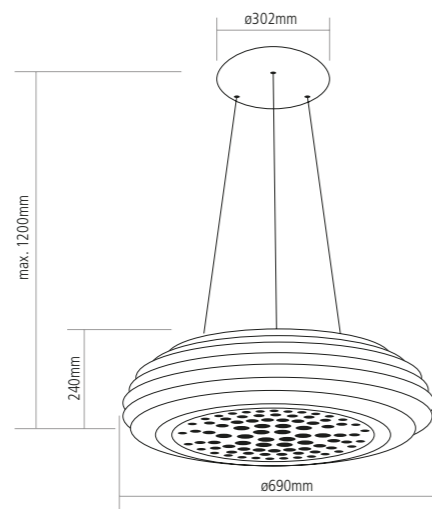

ZAL48SL / ZAL48CO / ZAL48BK

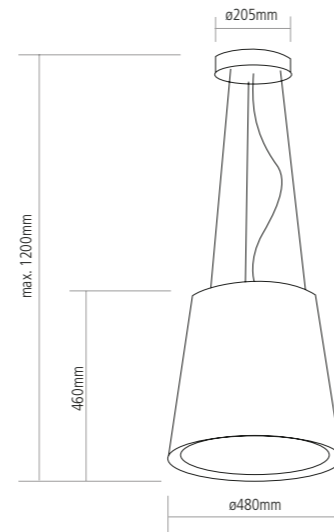

CGi921

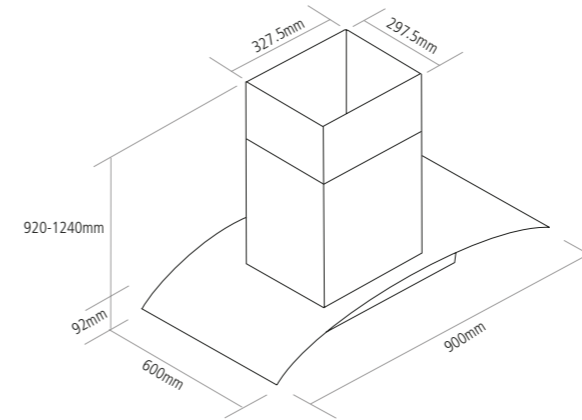

CGi920/RED

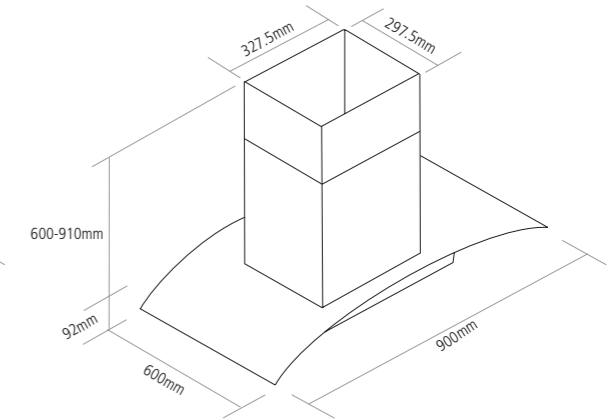

Note: Suitable to be installed in a standard room height of 2.3m

WALL CHIMNEY HOODS

Pi402

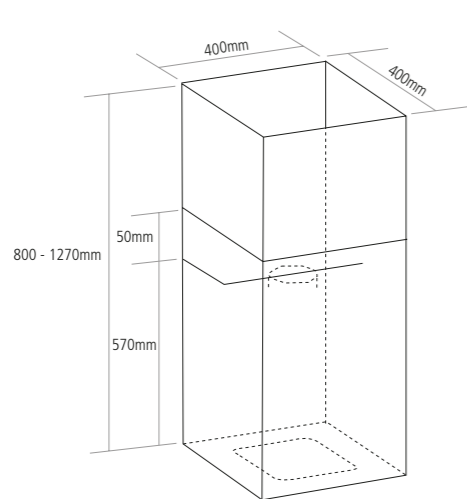

Oi363

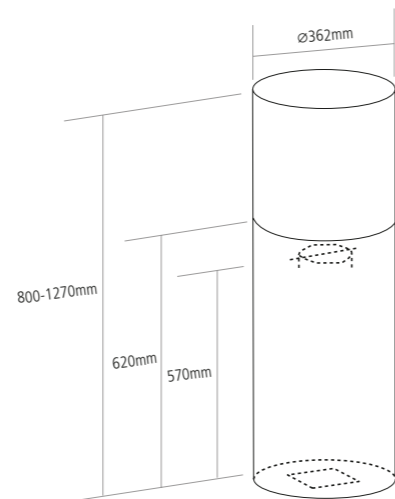

NOV800

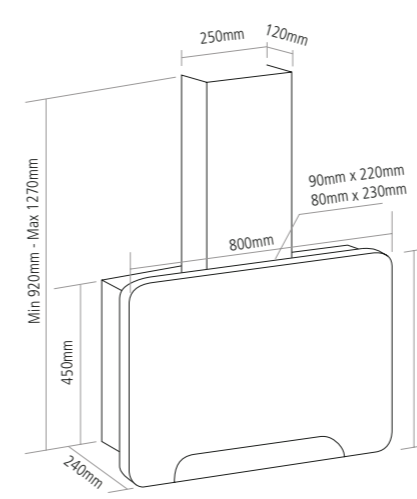

TAU760

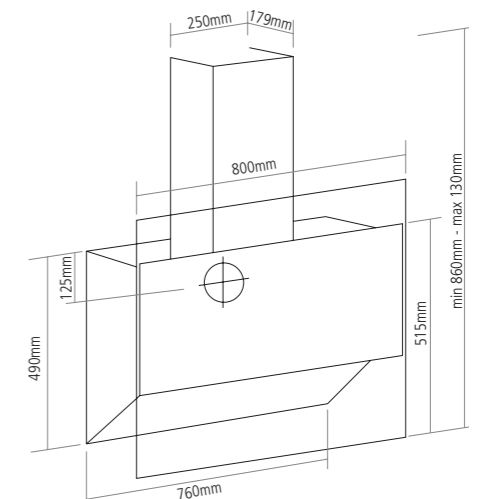



WALL CHIMNEY HOODS

MOT912

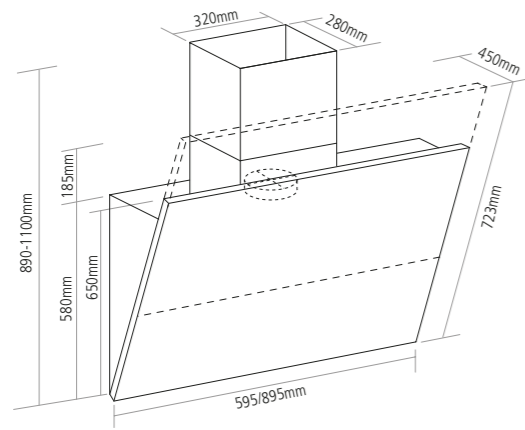

ZEL900 / ZEL900GM

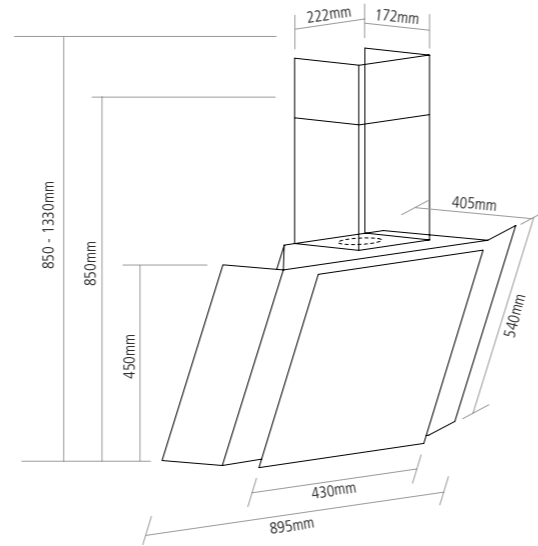

WALL CHIMNEY HOODS

ZC622

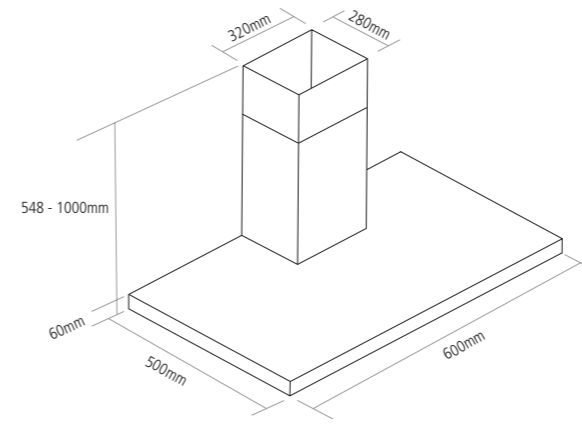

FGC920 / FGC720 / FGC620

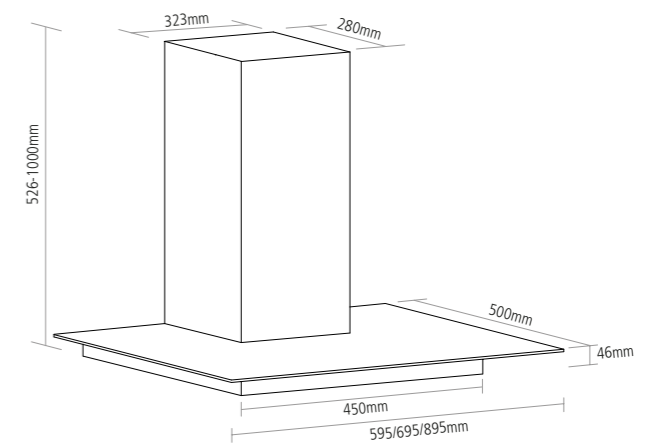

OM600

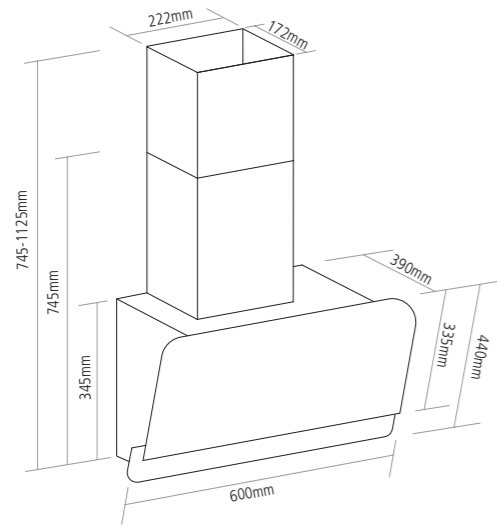

OM900

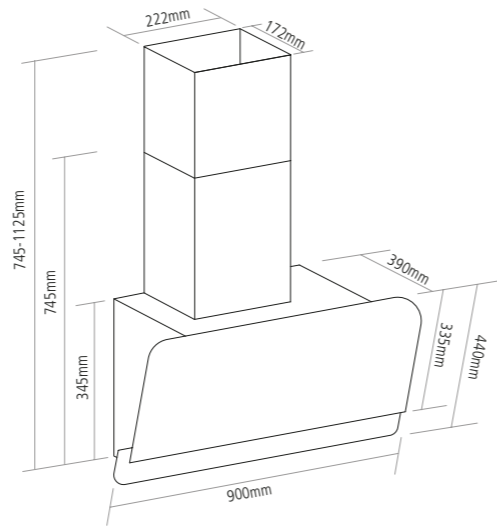

CGC911SS / CGC911BK

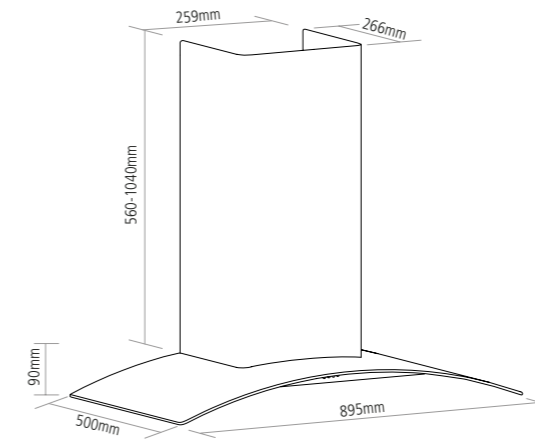

CGC711SS / CGC711BK

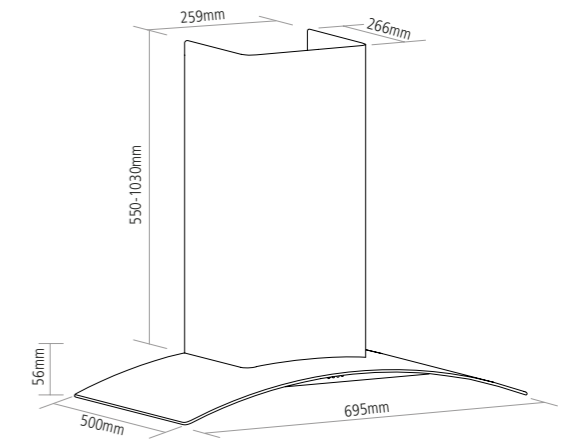

SP912BK / SP912SS / SP612BK / SP612SS

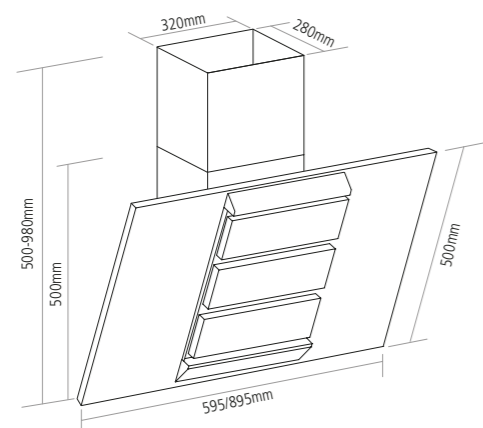

ZC922

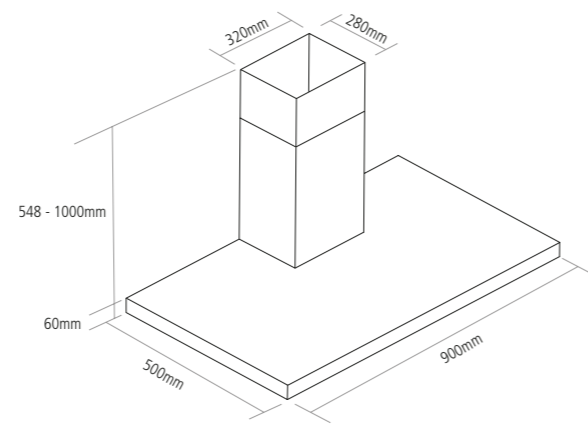

CGC611SS / CGC611BK

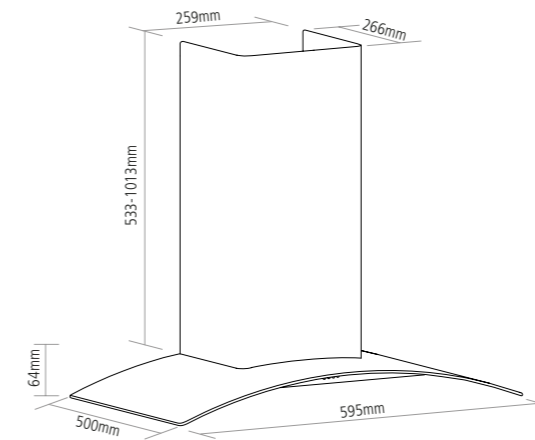

BXC911 / BXC611

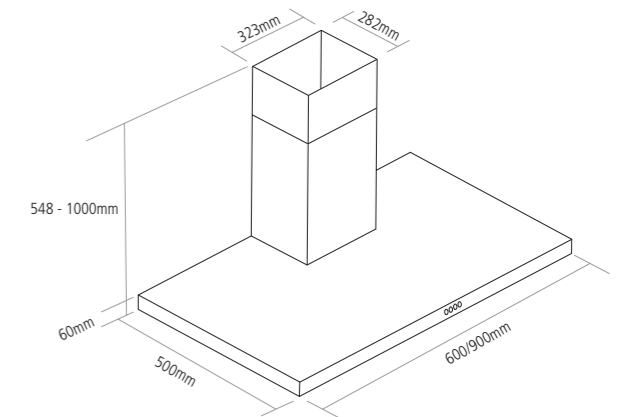

650mm space for electric hobs and 760mm space for gas hobs required from worktop to the mesh filter behind the centre glass panel. From the lowest point of the hood the distance required is 450mm for electric hobs and 550mm for gas hobs.

WALL CHIMNEY HOODS

CCH100

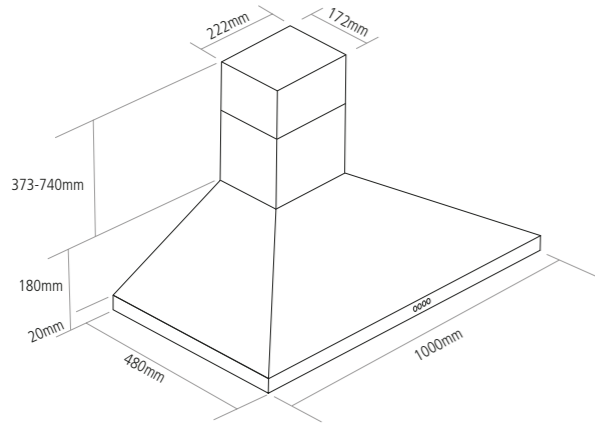

CCH901SS / CGC901BK

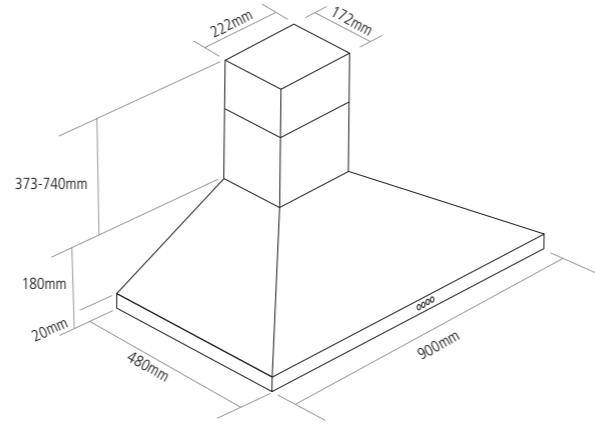

CCH700

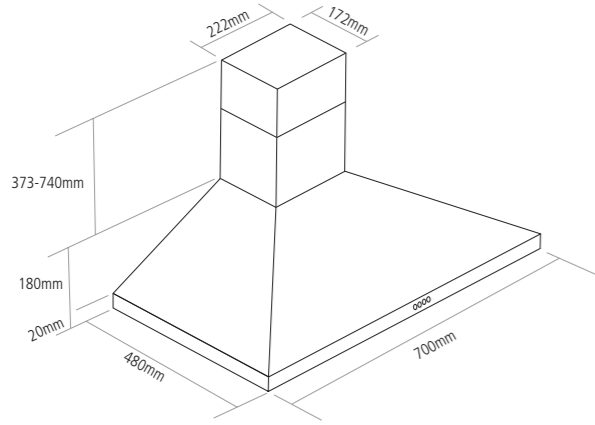

CCH601SS / CGC601BK

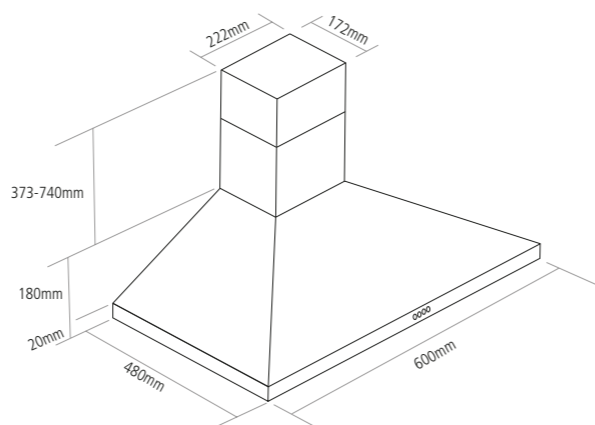

INTEGRATED HOOD

INCH

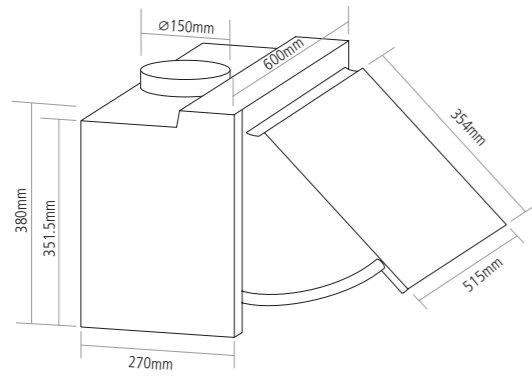

BUILT UNDER HOODS

TBU850

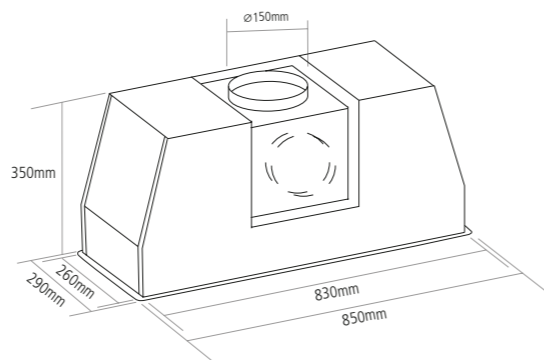

BUILT UNDER HOODS/CONVENTIONAL HOODS

TBU520

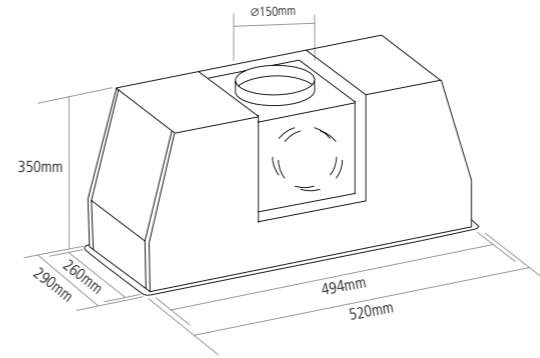

ST853

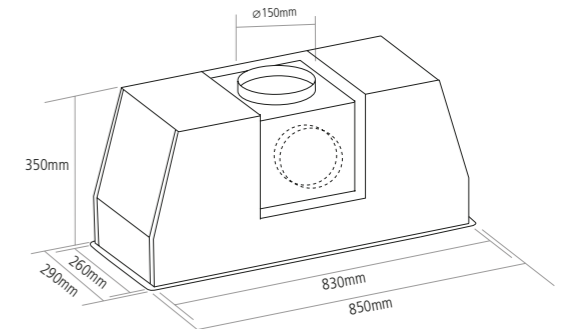

ST523

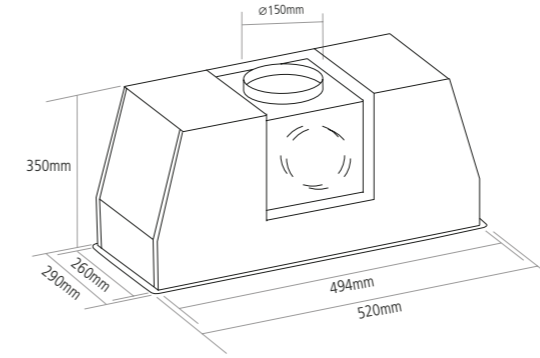

BU521

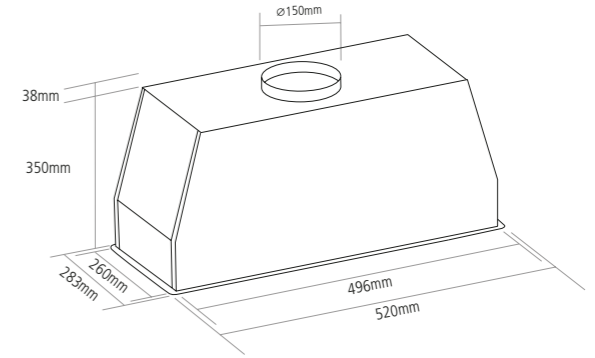

TSCH601

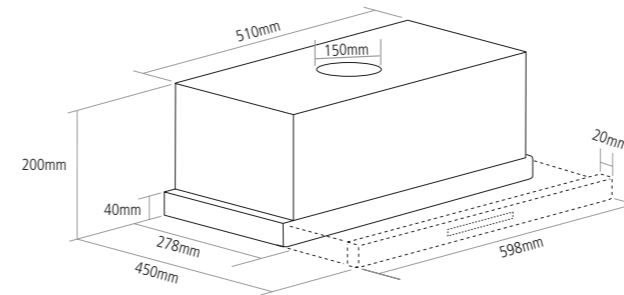

FSCHSS8

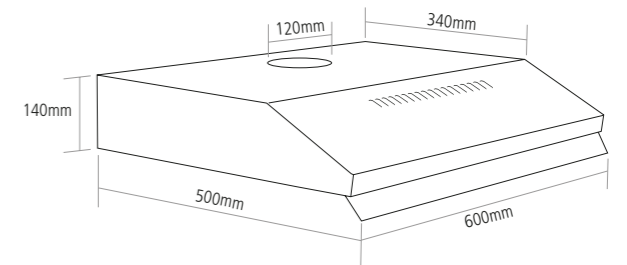

BUCH

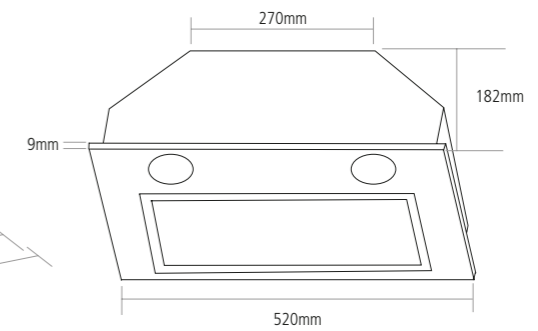



PROFESSIONAL REFRIGERATION

CAFF60 FREESTANDING

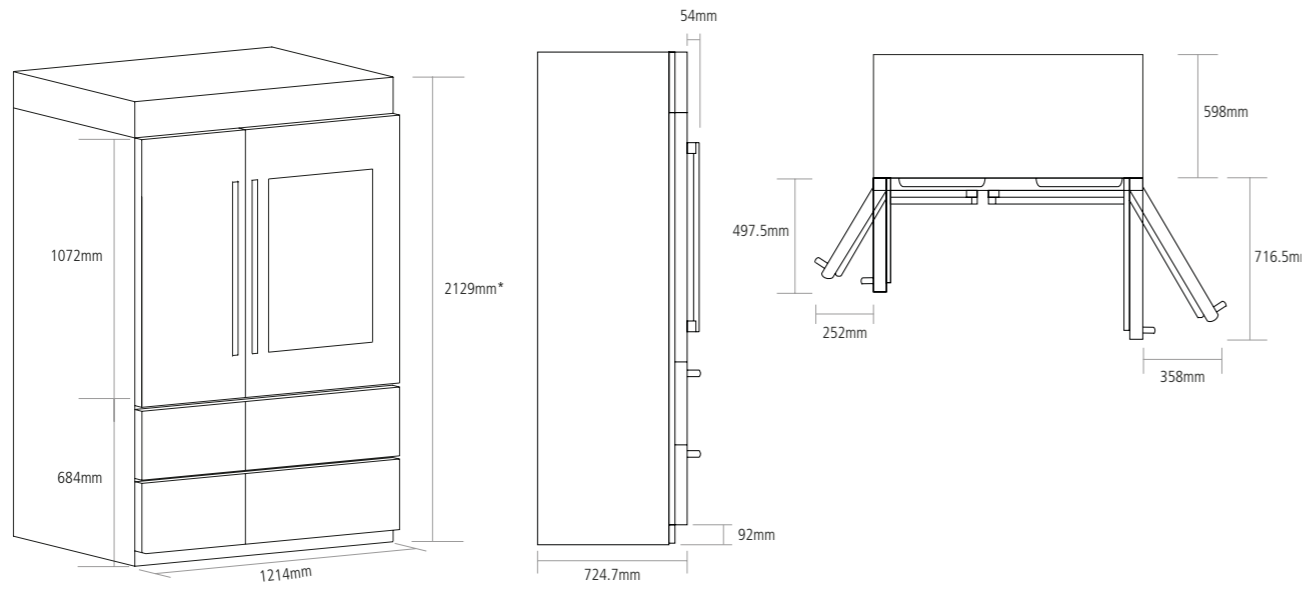

*Height of Product when feet are not extended, 2136mm when feet are extended.

FRENCH DOOR FRIDGE FREEZER

CAFF45GM

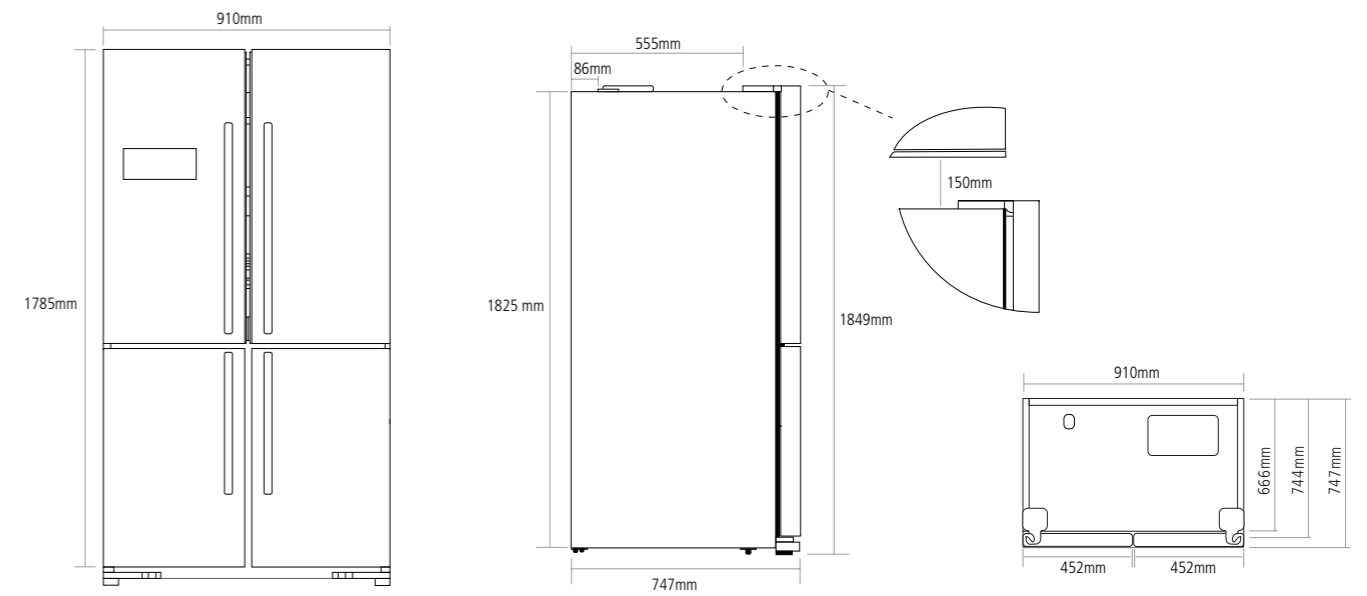

BUILT-IN

FREESTANDING

BUILT-IN

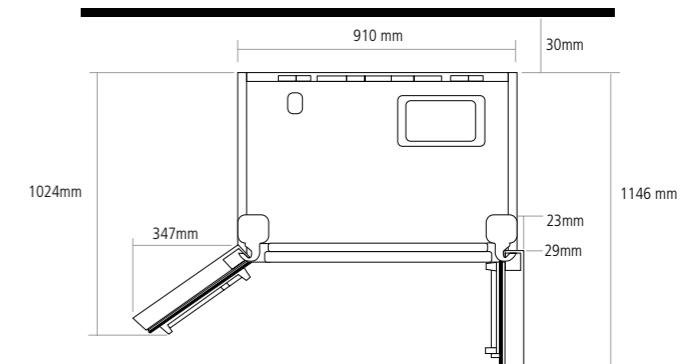
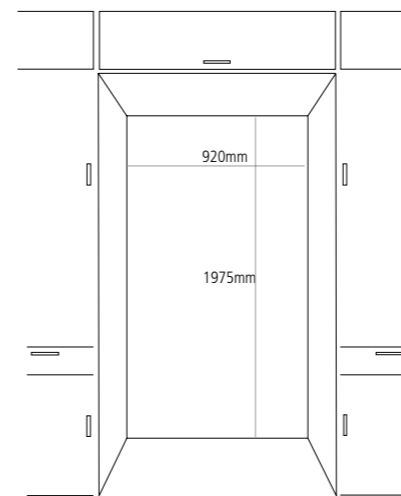
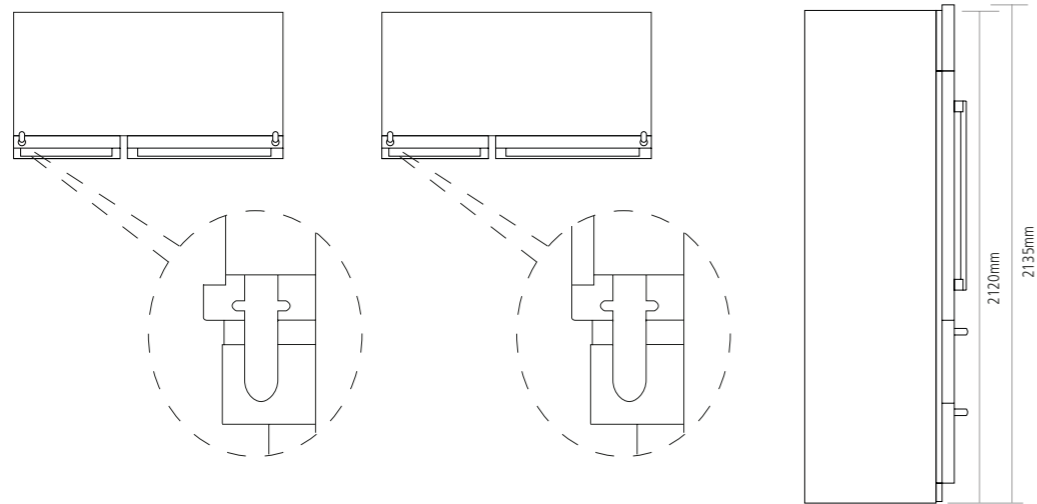

NOTE: refer to the installation instructions for the full details



FRENCH DOOR FRIDGE FREEZER

CAFF41

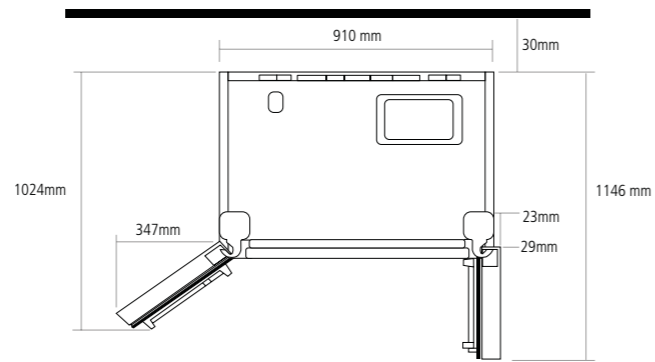
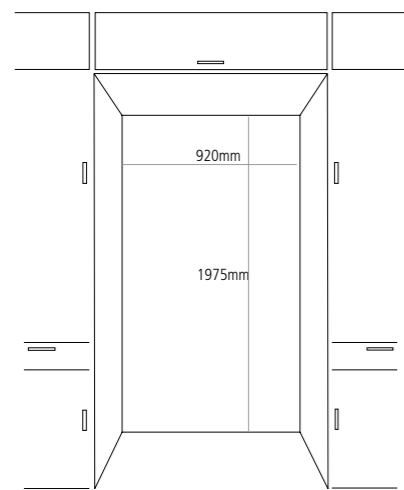
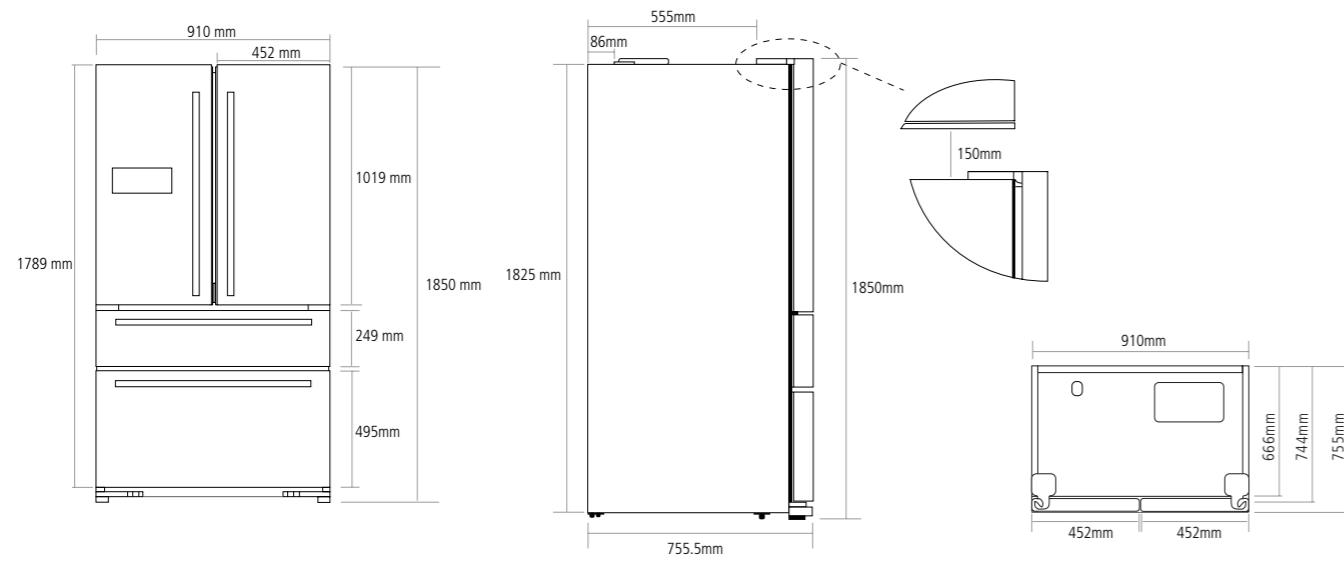

FREESTANDING REFRIGERATION

RFF730

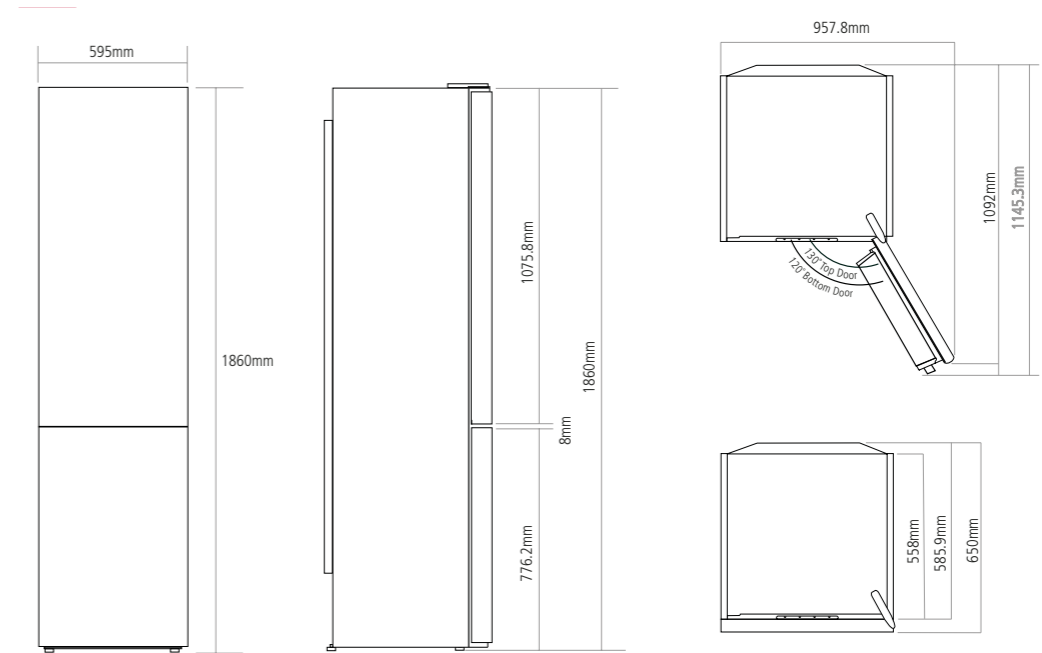

IN-COLUMN INTEGRATED REFRIGERATION

Ri7305 / Ri7300

Ri5505 / Ri5500

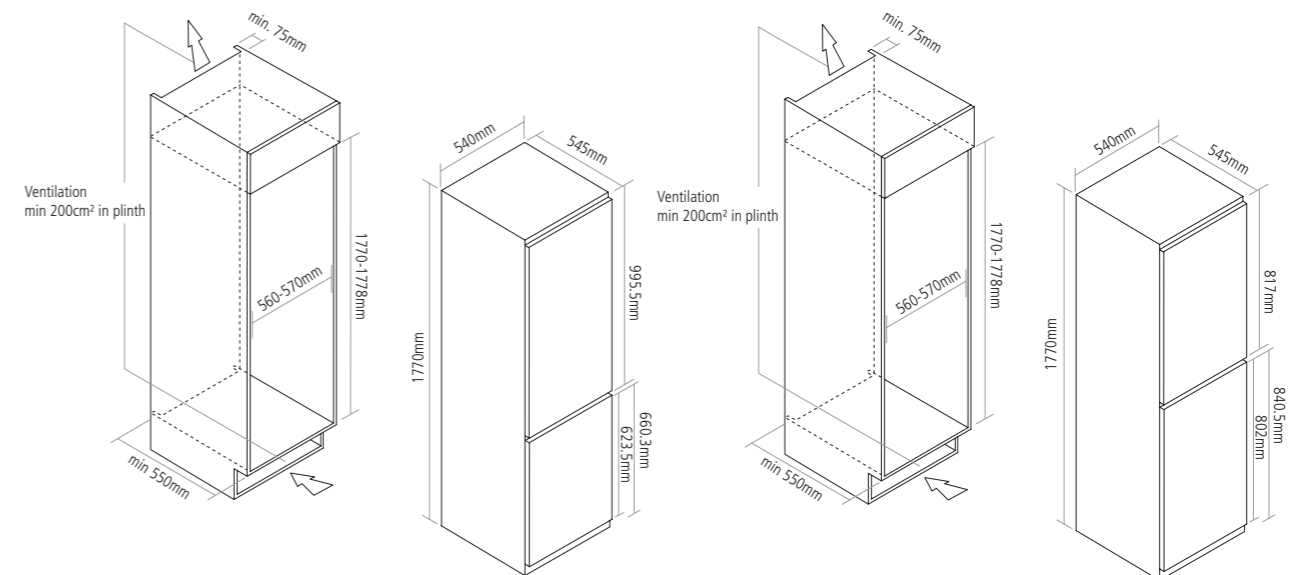

SIDE-BY-SIDE FRIDGE FREEZERS

CAFF23

CAFF207SS / CAFF207BK

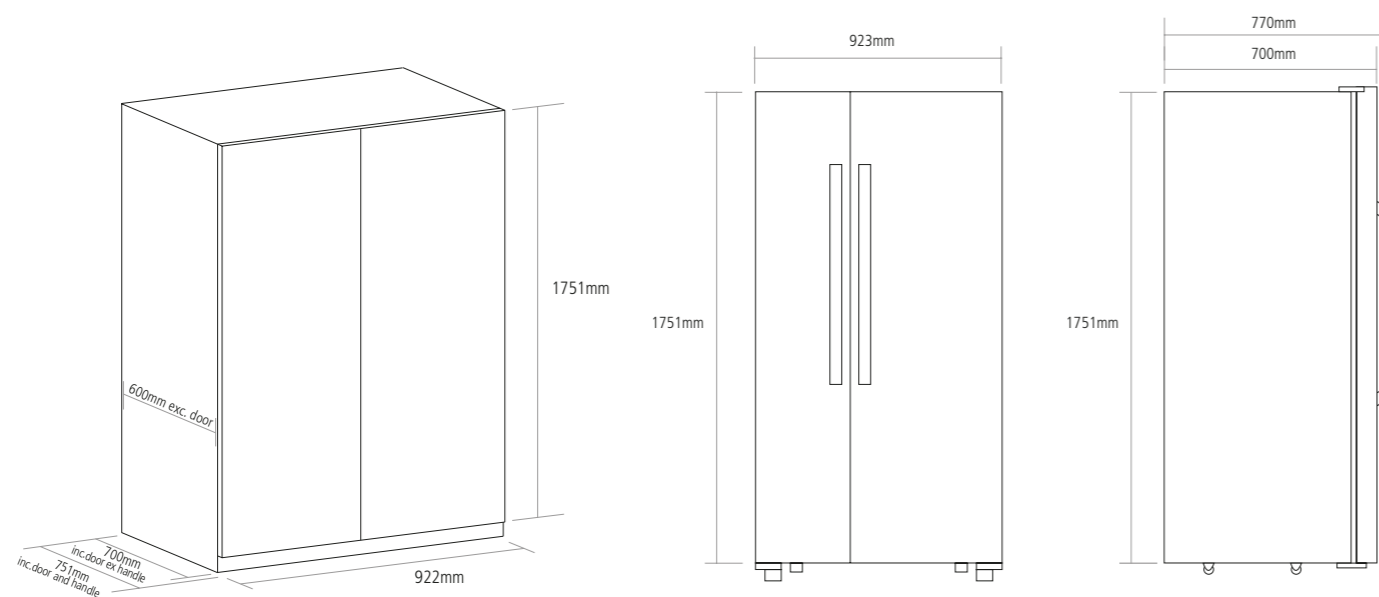

IN-COLUMN INTEGRATED REFRIGERATION

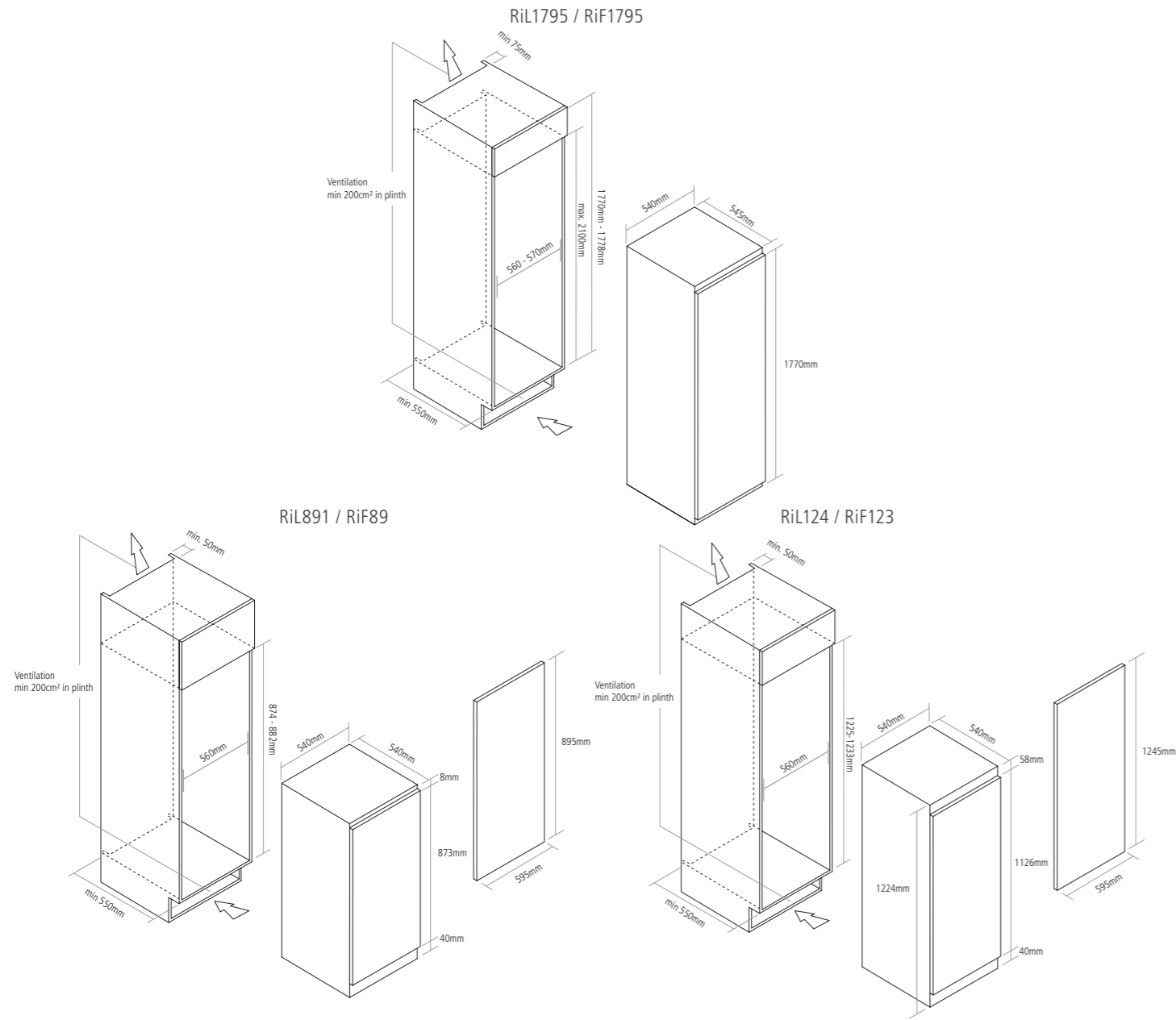

BUILT-UNDER INTEGRATED REFRIGERATION

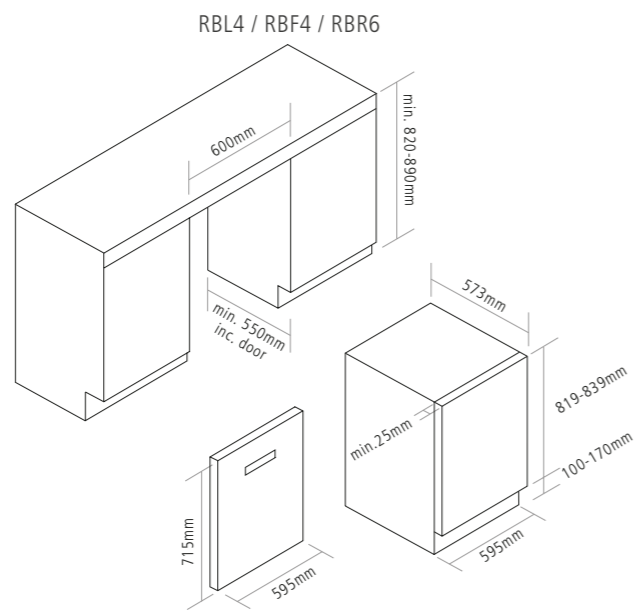

UNDERCOUNTER WINE CABINETS

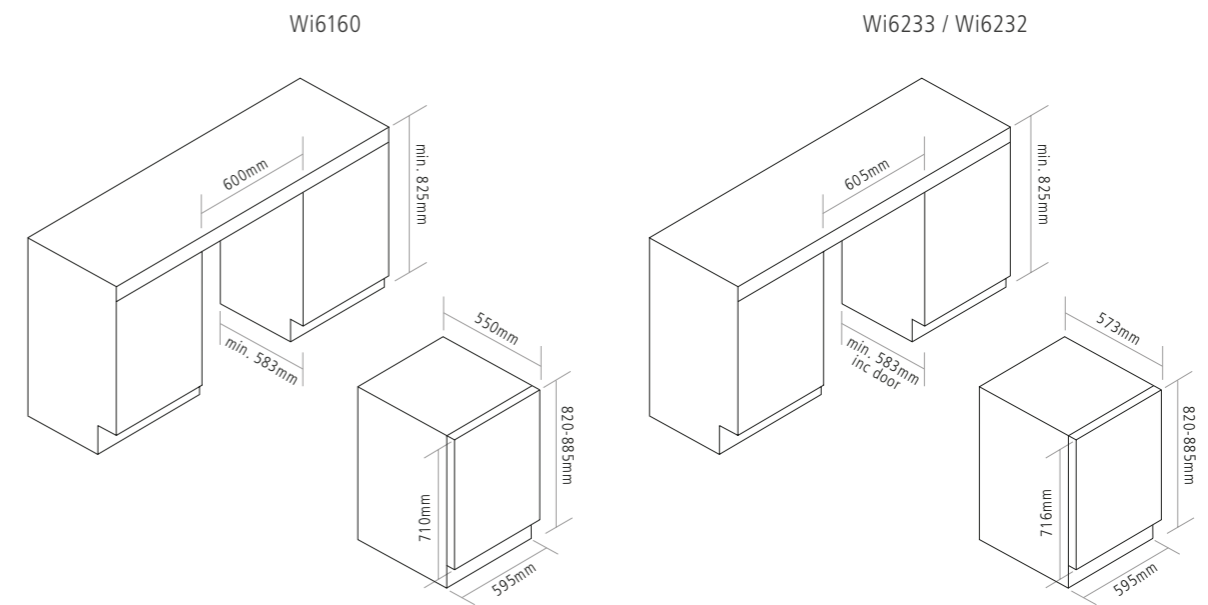

Wi6150 / Wi6134 / Wi6133 / Wi6133GM / Wi6134WH / Wi6141 / Wi6140

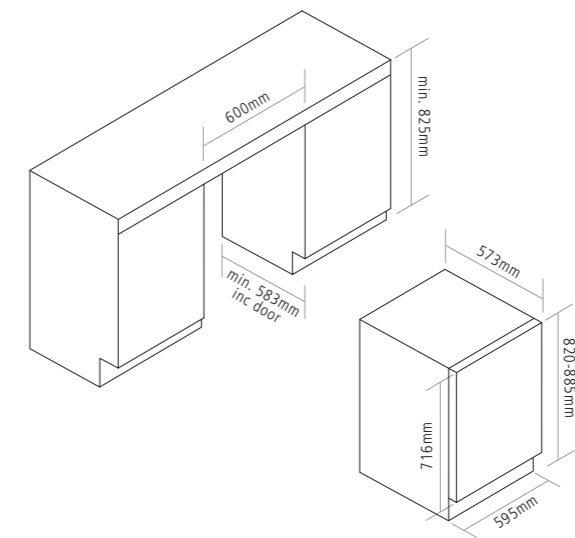

Wi3150 / Wi3124 / Wi3123 / Wi3124WH

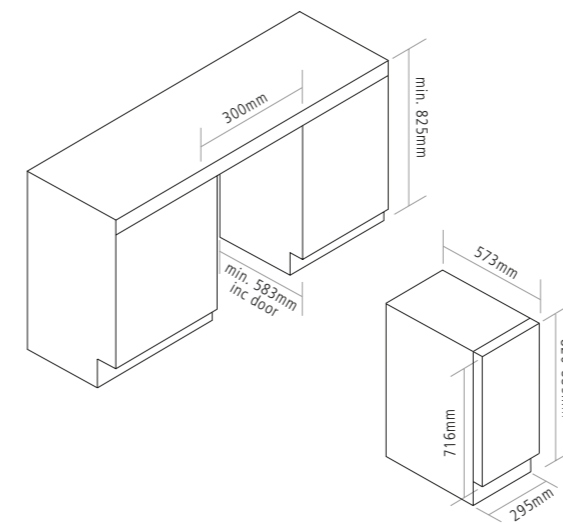

Wi156 / Wi157

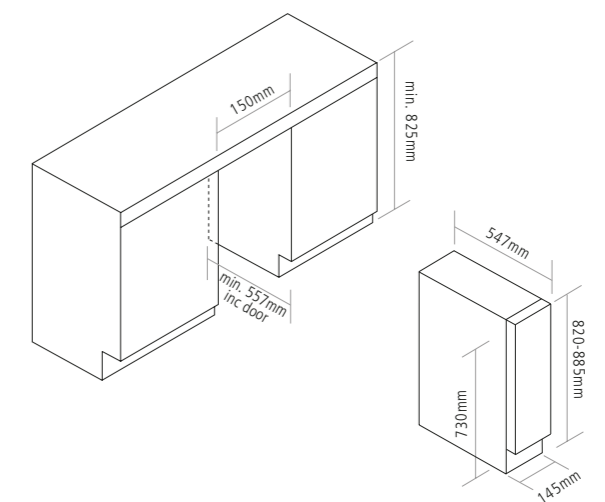



IN-COLUMN WINE CABINETS

WC1792 / WC1796

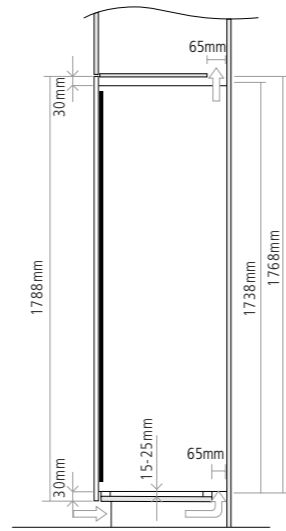
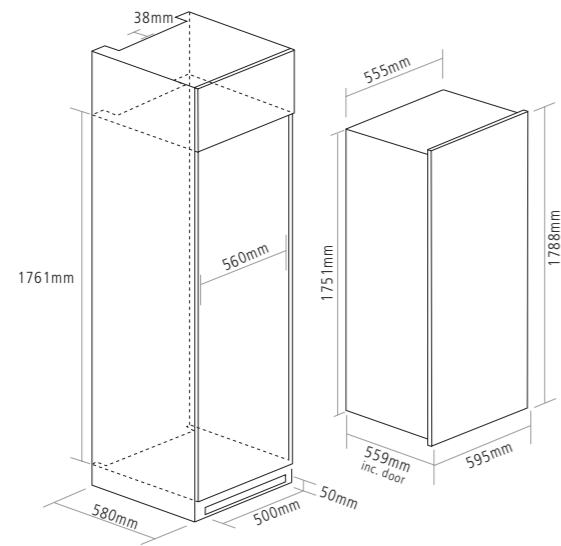

WC6520 / WC6510 / WC6500

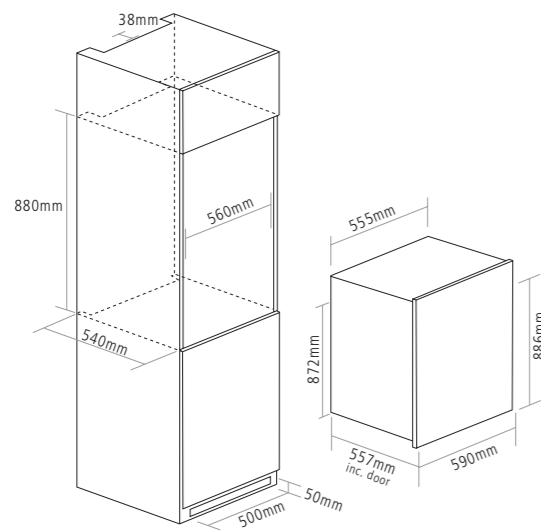

WC6410 / WC6400

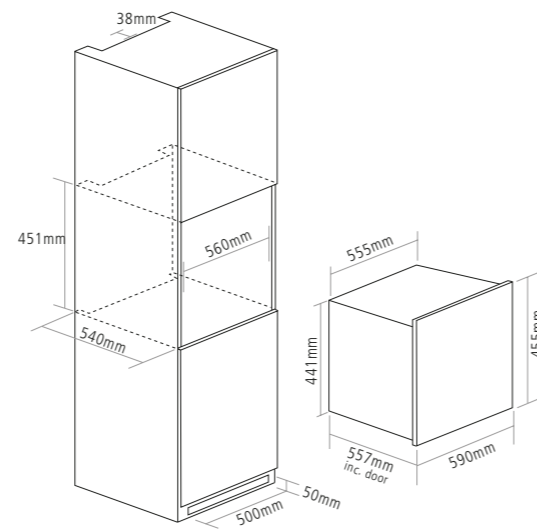

FREESTANDING WINE CABINETS

WF1549

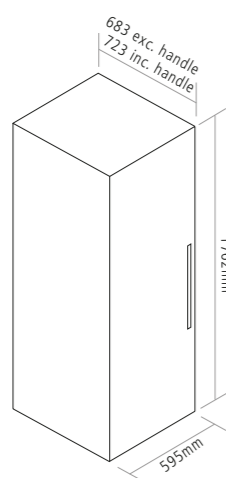

WF1548

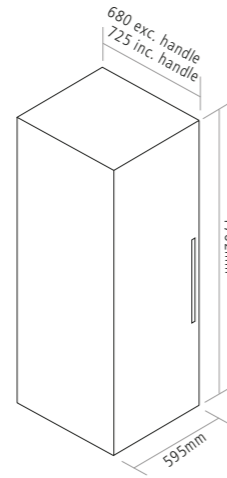

WF333*

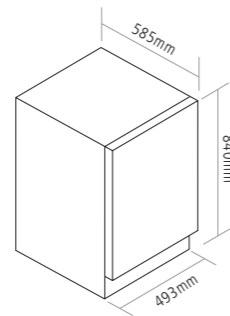

FULLY INTEGRATED DISHWASHERS

Di651 / Di641 / Di631

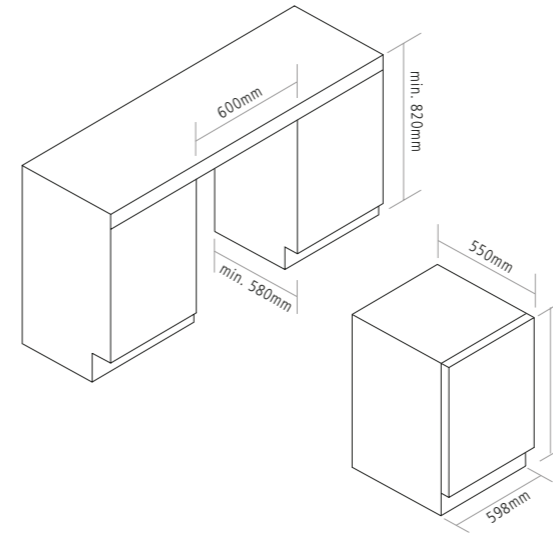

Di491 / Di481

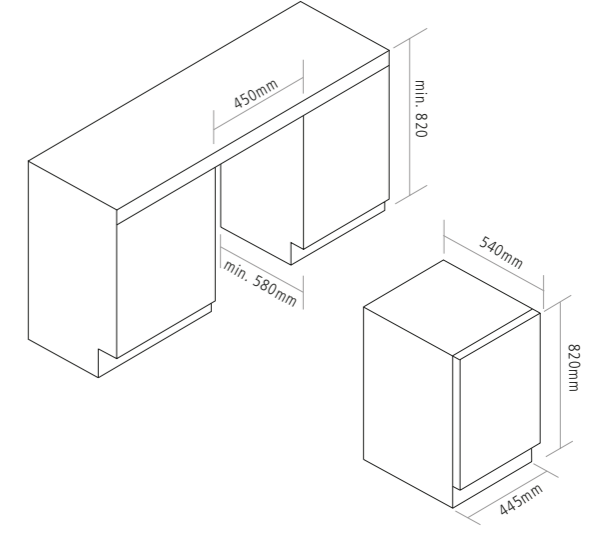

LAUNDRY

WMi3000 / WMi3005

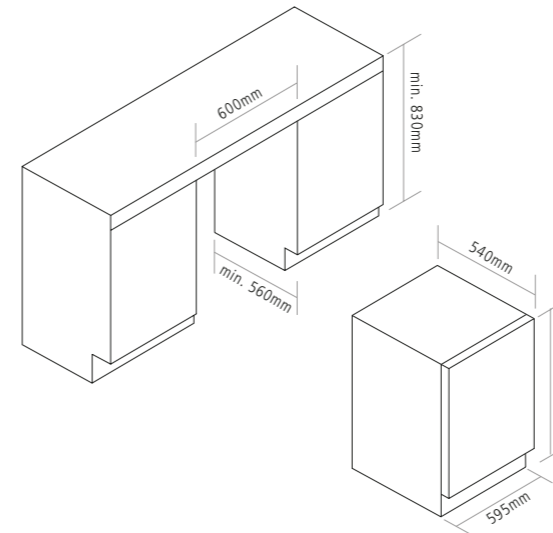

WDi3300

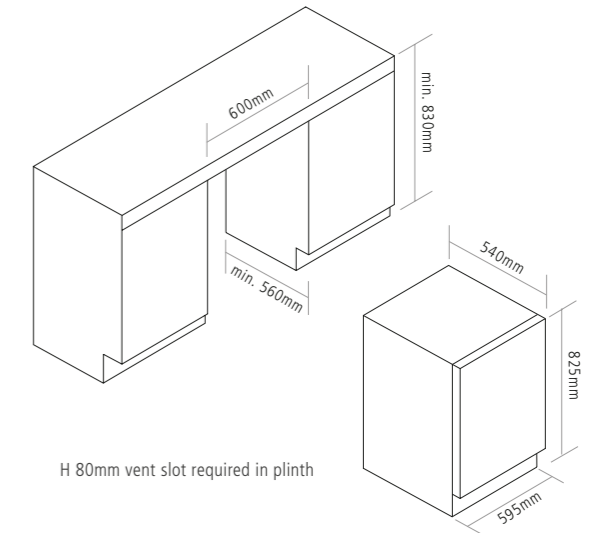

H 80mm vent slot required in plinth

TUMBLE DRYERS

TDi111 / TDi101

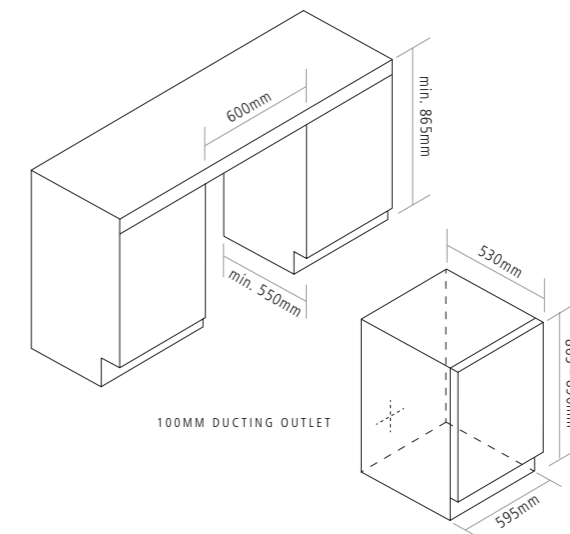

*Ventilation requirements - Please allow an 127mm gap around the whole appliance when installed next to a wall, unit or in an alcove



PERFORMANCE GUARANTEED



Here at Caple, performance and reliability are the most important features considered when designing and manufacturing our products. With that in mind, we have developed Caple Care, an after-care solution comprising of three tiers to give you that extra peace of mind.

See page 250 for more extended guarantee information.



FREE 2 YEAR GUARANTEE

Across all Caple appliances we offer a free 2 year guarantee on parts and labour. When selecting the components to design your perfect kitchen it is important you have the right assurance without spending an extra penny. All you need to do is visit our website or call us on 0330 123 0998 to register your free 2 year guarantee.



5 YEAR EXTENDED COVER

Why not extend your cover to 5 years? Caple Care 5 years parts and labour cover means for a one off payment or a monthly fee you can protect your appliance for a total of 5 years [including your free 2 year guarantee] on all parts and labour for any of your Caple appliances. Please visit our website for further details or see page 258.



OUT OF GUARANTEE

If you choose not to opt for a 5 year extended warranty, don't worry. Here at Caple we offer out of guarantee cover. So, if you are not covered under our extended warranty, for a fixed fee, we can still arrange a service call [including parts and labour] or a replacement product up to 6 years after the purchase date. Terms and conditions apply.

TO REGISTER YOUR FREE 2 YEAR GUARANTEE OR DISCUSS AN EXTENDED WARRANTY, CALL

0330 123 0998 OR VISIT CAPLE.CO.UK/REGISTER-YOUR-APPLIANCE

Lines are open 9am - 5pm Monday to Friday [excluding bank holidays].
Calls maybe recorded and monitored for quality and training purposes.
Full Terms and Conditions can be found at www.caple.co.uk.

CAPLE CARE



All Caple appliances come with a 2 year parts and labour guarantee.
You can extend this to provide a full 5 years parts and labour warranty.

THE BENEFITS OF TAKING OUT AN EXTENDED WARRANTY

The Caple protection plan has been carefully put together so customers who take out the extended cover benefit from:

5

Up to 5 years parts and labour warranty against breakdown



A nationwide network of Caple approved engineers to undertake repairs in the home

£

Spread the cost over 10 months with our monthly payment plan visit www.worldpay.com for full T&Cs



A replacement appliance should the repair of the original be uneconomic or impossible



Access to the Caple UK based contact centre

To register your free 2 year guarantee or discuss an extended warranty, call

0330 123 0998

Calls are charged at the local rate– please check with your provider for actual charges.

Register 
my appliance

TO REGISTER YOUR APPLIANCE WITH A FREE 2 YEAR GUARANTEE VISIT CAPLE.CO.UK
Subject to terms and conditions



Fourth Way
Avonmouth
Bristol
BS11 8DW

t: 0117 938 1900
f: 0800 373 163
e: sales@caple.co.uk
caple.co.uk



CapleUK



caple



capleuk

Issue: CA0219

